

2025 LASER BEAM ANALYSIS

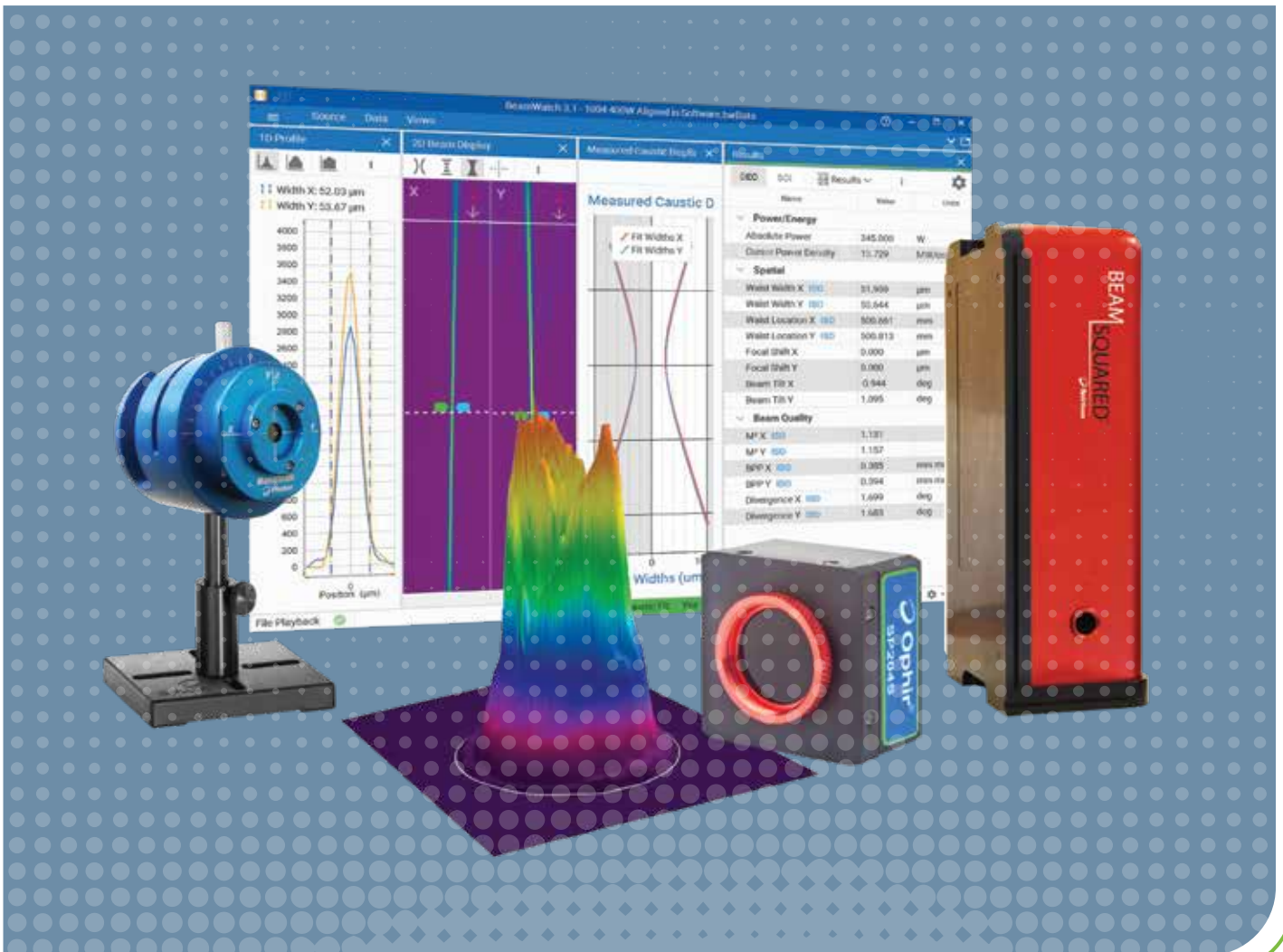
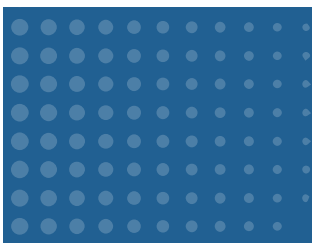

CONTENTS

	About Ophir Optronics Solutions Ltd.	5
	Ophir Power and Energy Meters - Versatility for Every Application	7
	Calibration Capability at Ophir	8
1.0	Sensors	9
	Laser Power and Energy Sensors Table of Contents	10
	Sensor Finder Program	16
	General Introduction	18
1.1	Power Sensors	20
	Power Sensors - Introduction	21
1.1.1	Photodiode Power Sensors	25
1.1.1.1	Standard Photodiode Sensors 20pW - 3W	25
1.1.1.2	Round Photodiode Sensors 20pW - 3W	28
1.1.1.3	Special Photodiode Sensors 50pW - 1W and 20mLux - 200kLux	29
1.1.1.4	Graphs	31
1.1.1.5	Accessories for Photodiode Sensors	33
1.1.1.6	Integrating Spheres	34
1.1.1.6.1	Integrating Spheres - Small Dimensions 1"-1.6", 500nW - 3W	35
1.1.1.6.2	Integrating Spheres - VIS 1.5" High Speed Response, Multi-functional 400nW - 4W	36
1.1.1.6.3	Integrating Spheres - NIR 1.5" High Speed Response, Multi-functional 600nW - 3W	37
1.1.1.6.4	Integrating Spheres - Large Dimensions 5.3"	38
1.1.1.6.5	Accessories for IS6	40
1.1.1.7	LED measurement - UV, VIS, NIR	41
1.1.1.7.1	LED power sensors 20pW - 3W	41
1.1.1.7.2	LED Irradiance and Dosage Sensors 100nW/cm ² - 15W/cm ²	43
1.1.2	Thermal Power Sensors	44
	Absorption Angle Dependence and Damage Graphs for Thermal Sensors	44
1.1.2.1	Low Noise Lock in Power Sensors 300fW - 100mW	45
1.1.2.2	High Sensitivity Thermal Sensors 8μW - 12W	47
1.1.2.3	Low Power Thermal Sensors 10mW - 50W	51
1.1.2.3.1	Low Power BeamTrack - Power / Position / Size Sensors 100μW - 10W	55
1.1.2.3.2	Beam Trap up to 50W	57
1.1.2.4	Low - Medium Power Thermal Sensors 30mW - 200W	58
1.1.2.4.1	Medium Power BeamTrack - Power / Position / Size Sensors 40mW - 150W	62
1.1.2.4.2	Standard OEM Smart Sensors 10mW - 150W	64
1.1.2.5	Medium Power Large Aperture Thermal Sensors 300mW - 500W, 100mJ - 10,000J	66
1.1.2.5.1	Sensors for Intense Pulsed Light IPL 100mJ - 2000J	70
1.1.2.6	Medium - High Power Fan Cooled Thermal Sensors 10mW - 1100W	72
1.1.2.6.1	Medium - High Power BeamTrack - Power / Position / Size Sensors 150mW - 1000W	76
1.1.2.7	High Power Thermal Sensors	78
1.1.2.7.1	High Power Thermal Sensors - Introduction	78
1.1.2.7.2	Medium Power Water Cooled Thermal Sensors 0.5W - 300W	79
1.1.2.7.3	High Power Water Cooled Thermal Sensors 5W - 5000W	80
1.1.2.7.4	Very High Power Water Cooled Thermal Sensors 100W - 30kW	87
1.1.2.8	Calorimetric Power Meters 200W - 150kW	90
1.1.2.8.1	High Power Water Cooled Calorimetric Sensor 200W - 6000W	90
1.1.2.8.2	Very High Power Water Cooled Calorimetric Sensors 100W - 150kW	91
1.1.2.9	IPM industrial High Power Sensor	93
	IPM industrial High Power Sensor - Introduction	93

1.1.2.9.1	IPM-10KW - Industrial Sensor 100W - 11kW	94
1.1.2.9.2	IPM-SHUTTER10 Shutter Assembly for IPM-10KW	96
1.1.2.9.3	IPM-COM - IPM adapter for industrial protocols	97
1.1.2.10	Beam Dumps Up to 11kW	98
1.1.2.11	Accessories for High Power Water Cooled Sensors	99
1.1.2.11.1	Fiber Adapter for Ophir High Power Sensors	99
1.1.2.11.2	Protective Housing for 5000W, 10K-W and 15K-W Series Sensors	100
1.1.2.11.3	Scatter Shield	101
1.1.2.11.4	Heavy Stand for 10K-W and 15K-W	101
1.1.2.11.5	30K-W Rubber Feet Assembly	101
1.1.2.11.6	Metric Water Connectors for Water Cooled Sensors	102
1.1.2.11.7	Protective Covers with Target Pattern for High Power Sensors and for Scatter Shields	102
1.1.2.12	Short Exposure High Power Sensors 200mW - 12,000W	103
1.1.2.12.1	Helios Pro 100W - 12,000W	103
1.1.2.12.2	Ariel 200mW - 8000W	106
1.1.2.12.3	Pulsed Power Mode 300mW - 10,000W	108
1.1.2.12.4	Comet Power Pucks 20W - 10,000W	110
1.1.3	BeamTrack Power / Position / Size Sensors	111
1.1.3.1	BeamTrack - Introduction	111
1.1.3.2	BeamTrack - Device Software Support	112
1.1.3.3	BeamTrack - PC Software Support	113
1.1.3.4	Low Power BeamTrack Power / Position / Size Sensors 100μW - 10W	114
1.1.3.5	Medium Power BeamTrack Power / Position / Size Sensors 40mW - 150W	116
1.1.3.6	Medium - High Power BeamTrack Power / Position / Size Sensors 150mW - 1000W	118
1.1.4	Accessories for Thermal Sensors	120
1.1.4.1	Fiberoptics Adapters	120
1.1.4.2	Other Accessories	121
1.2	Energy Sensors	122
	Energy Sensors- Introduction	123
	Absorption and Damage Graphs for Pyroelectric Sensors	124
	Wavelength Range and Repetition Rate for Energy Sensors	125
1.2.1	Photodiode Energy Sensors 10pJ - 15μJ	126
1.2.2	Pyroelectric Energy Sensors 0.1μJ - 10J	128
1.2.3	High Energy Pyroelectric Sensors 10μJ - 40J	132
1.2.4	Energy Sensors Accessories	140
1.2.4.1	Accessories for Pyroelectric Sensors	140
1.3	Pulse Characterization Sensors	142
	Pulse Characterization Sensors Introduction	143
1.3.1	Fast Photodiode Detectors (FPD)	144
1.4	Customized Solutions (OEM)	146
1.4.1	Customized Solutions (OEM) Introduction	147
1.4.2	Thermal and Photodiode Customized Solutions (OEM) sensors	148
1.4.2.1	Sensor Usage	148
1.4.2.2	Advantages of Ophir Thermal and Photodiode Customized Solutions (OEM) Sensors	149
1.4.2.3	Standard Customized Solutions (OEM) Thermal and Photodiode Sensors 100pW - 600W	150
1.4.2.4	Examples of Custom OEM Thermal and Photodiode Sensor Solutions	163
1.4.3	Pyroelectric Customized Solutions (OEM) Sensors	164
1.4.3.1	Standard Pyroelectric OEM Sensors - Introduction	164
1.4.3.2	Standard Pyroelectric Customized Solutions (OEM) Sensors <0.1μJ - 40J	165

2.0	Power Meters	167
	Power Meter Finder	168
	Comparison of Hand Held Meters	170
	Measuring Modes Available: Sensor Type / Device	171
	Power Meters and PC Interfaces	172
2.1	Power Meters	173
2.1.1	Centauri	173
2.1.2	StarBright	175
2.1.3	Vega	177
2.1.4	Nova II	179
2.1.5	StarLite	181
2.1.6	NOVA	183
2.1.7	Accessories	185
2.2	PC Interfaces	186
2.2.1	PC Connectivity Options for Power / Energy Measurement	186
2.2.2	Compact Juno USB Interface	187
2.2.3	Juno+ USB Interface	188
2.2.4	Juno-RS RS232 Interface	189
2.2.5	EA-1 Compact Ethernet Adapter	190
2.2.6	Pulsar Multichannel and Triggered USB Interfaces	191
2.2.7	Quasar Wireless Bluetooth Interface	192
2.2.8	Summary of Computer Options for Ophir Meters and Interfaces	193
2.3	Software Solutions	194
2.3.1	StarLab	194
2.3.2	System Integrator Solutions	198
2.3.3	StarCom	199
2.3.4	LabVIEW Solutions	200
2.3.5	StarViewer Android & iOS Apps	201
3.0	Laser Beam Analysis	203
3.1	Choosing a Beam Profiler	204
3.1.1	Basic Questions	204
3.1.2	Beam Profiler Finder	206
3.1.3	User Guide for Choosing the Optimum Beam Profiling System	208
3.2	Benefits of Beam Profiling	210
3.3	Introduction to Camera-Based Profilers	211
3.3.1	BeamGage® - Standard Version	212
3.3.2	BeamGage® -Professional Version	219
3.3.3	Software Comparison Chart	221
3.3.4	Cameras for BeamGage®	226
3.3.4.1	190-1100nm Cameras	228
3.3.4.1.1	USB Silicon High Resolution CMOS Camera	228
3.3.4.1.2	Large Format USB & GigE Cameras	229
3.3.4.2	1440-1605nm Cameras	230
3.3.4.2.1	Phosphor Coated CMOS And CCD Cameras For NIR Response	231
3.3.4.3	900-1700nm Cameras	232
3.3.4.3.1	GigE InGaAs NIR Camera	232
3.3.4.4	13-355nm and 1.06-3000µm Cameras	233
3.3.4.4.1	Pyroelectric Array Cameras	237

3.3.5	BeamMic™ - Basic Laser Beam Analyzer System	239
3.3.5.1	Software Specifications	240
3.3.5.2	Cameras for BeamMic™	243
3.3.6	Focal Spot Analyzer	244
3.4	Introduction to Scanning-Slit Profilers	246
3.4.1	NanoScan 2s	247
3.4.1.1	Software Comparison Chart	251
3.5	Accessories for Beam Profiling	254
3.5.1	Neutral Density Attenuators/Filters	254
3.5.2	Beam Splitter + Neutral Density Filters Combo	257
3.5.3	Beam Splitter	263
3.5.4	Beam Expanders Microscope Objectives	266
3.5.5	Beam Reducers	268
3.5.6	CCTV Lens for Front Imaging Through Glass or Reflected Surface	269
3.5.7	WB-I: Wide Beam Imager	270
3.5.8	Imaging UV Lasers	272
3.5.9	Integrated Solutions	273
3.5.10	Optical Camera Trigger	274
3.6	Near Field Profilers	275
3.7	What is M²?	276
3.7.1	Camera Based Beam Near-Field Propagation Analyzer: M ²	277
3.7.1.1	BeamSquared®	277
3.8	BeamWatch® Family	282
3.8.1	Introduction to Rayleigh Scattering Measurement Technology	282
3.8.2	BeamWatch® & BeamWatch®Plus Non-contact, M ² , Focus Spot Size and Position Monitor for high power NIR and VIS lasers	284
3.8.3	BeamWatch® Integrated - Beam Characterization System for Automated Manufacturing	286
3.8.3.1	BeamWatch Integrated 150	287
3.8.3.2	BeamWatch Integrated 500	288
3.9	Additive Manufacturing Systems	289
3.9.1	BeamPeek™	290
3.9.2	BeamWatch® AM	292
	Product Index	294
	Part Number Index	305
	Distributors List	308

ABOUT OPHIR OPTRONICS SOLUTIONS LTD.

Ophir Optronics Solutions Ltd., a Part of MKS instruments, Inc. was founded in 1976, as an optical coating company that has grown and diversified into other areas. Ophir employs a highly-qualified staff of over 570 engineers, technicians and skilled workers. Our company products are sold worldwide through a distribution network that includes four fully certified calibration facilities and repair centers. The majority of Ophir's laser measuring instrumentation line is exported and marketed by sales representatives in more than 35 countries around the world, the largest markets being the USA, Europe and Japan.

About MKS instruments

MKS Instruments, Inc. is a global provider of instruments, subsystems and process control solutions that measure, control, power, monitor and analyze critical parameters of advanced manufacturing processes to improve process performance and productivity. MKS's products are derived from their core competencies in pressure measurement and control, materials delivery, gas composition analysis, control and information technology, power and reactive gas generation, vacuum technology, photonics, lasers, optics and motion control. MKS's primary served markets are manufacturers of capital equipment for thin film including semiconductor devices, process manufacturing, environmental, life sciences and scientific research.

Our Facilities

Sited in an impressive 10,400 sq.m. (112,500 sq.ft.) building in Jerusalem, Israel, Ophir's main manufacturing and R&D facility is fully equipped for both the production and testing of laser measuring instrumentation, optical components and coatings. In addition, Ophir's modern facilities have in-house capability for diamond turning, aspheric optics and electronic equipment assembly.

Ophir's wide-ranging activities include:

- Production of the most complete variety of laser measurement instrumentation in existence, both off-the shelf and Customized Solutions (OEM). Production of very high precision infrared and visible optical components: lenses, mirrors, metallic optics (spherical, aspherical and diffractive), windows, domes and prisms, suitable for military (FLIR) and industrial (CO₂) applications. Ophir, a qualified manufacturer for some of the world's leading suppliers of night vision equipment, is renowned for having developed some of the highest performing and most cost-effective optical systems in the world.
- Design and production of optical assemblies. Thin film optical coatings.
- Non-contact optical equipment for distance measurement and three-dimensional mapping of objects developed by Optimet, a company in which Ophir has a majority share. These devices are based on patented

technology called Conoscopic Holography. Applications include dentistry microelectronics, robotics, quality control and mechanical shops.

Laser Development

The history of laser development has been characterized by ever-increasing laser powers and energies and increasingly concentrated laser beams. Medical, industrial and scientific applications of these high power and energy density lasers require reliable and accurate measurement of power and energy.

Meters for relatively high powers and energies generally operate by measuring the heat deposited onto an absorbing element. The key to accurate and reliable measurement is the makeup of this absorbing surface. It must stand up to repeated use without degradation or change in calibration. Laser sources are constantly growing in power, energy and beam concentration. Ophir has an ongoing program of development of durable absorbing surfaces that will continue to stand up to the most punishing laser sources as they grow in intensity and Ophir has some of the highest damage threshold absorbers in the industry.

Ophir - Spiricon - Photon brings the same leading edge innovation to laser beam profile measurement with its famous Pyrocam, its in house designed SP and Nanoscan cameras and BeamGage software.

Ophir's Laser Measurement Group products are used in three highly competitive and sophisticated fields: medical, industrial and research. Each of these areas is further divided into end users and OEMs.

Medical

Ophir is the largest producer of laser power and energy measurement equipment for the medical market, where Ophir's power measurement devices are incorporated into laser-based instrumentation. Our products are vital to medical laser manufacturers and to the hospitals and doctors who are end-user laser purchasers.

Medical lasers cover the entire spectrum of wavelengths from the 193 nm excimer laser to the 10.6 micron CO₂ laser where the main laser wavelengths are 193, 248, 532, 694, 755, 808, 1064, 2100, 2940 and 10600 nm. These lasers are used for general surgery, eye surgery, gynecology, ORL, dermatology and other applications. They have outputs which start at mW and mJ on the low end going up to tens of joules and hundreds of watts at the high end. The trend in medical lasers is to progress to more powerful systems, especially in the dermatology field, and to introduce diode lasers and intense pulsed light (IPL) sources instead of the traditional gas or solid state lasers.

Ophir has developed special equipment that can for the first time measure the output of IPL sources.

Regulating bodies such as the FDA in the USA require the manufacturers to have at least one channel of power or



energy monitoring in each laser. Ophir's high-quality OEM products provide an extraordinarily efficient answer to this requirement.

Industrial

Industrial laser customers include both laser manufacturers and laser users in job shops and factories. Ophir answers the needs of this market by providing measurement systems that have a high damage threshold and the ability to measure high repetition rates with high accuracy. There are several main types of lasers for industrial and material processing applications: Fiber Lasers, Diode, Nd:YAG lasers and Solid-state/disk lasers in the range of 980-1070 nm with some systems in blue and green range. A significant market share still remains with CO₂ laser at 10.6 microns. They are characterized by their high power output, which ranges from 100W to 120kW, depending on the application. With its capabilities in power, energy and profile measurement, Ophir has developed many products for this market including an integrated Laser Beam Analyzer for industrial YAG lasers which measures beam profile, temporal profile, power and energy, all in one unit. A subset of the industrial market is the microelectronics industry, which uses excimer lasers for exposing the photoresist in the photolithography process. This process uses lasers with a short wavelength of 193 to 345 nm that operate at high repetition rate and high energy. The main factor influencing

the component density possible on the microchip is the wavelength of the laser already used in the process, and therefore the trend is to progress to shorter wavelengths. Ophir has a range of unique products specified for the photolithography market, including off-the-shelf and Customized Solutions (OEM) products.

RoHS

Almost all Ophir and Spiricon Laser measurement products are RoHS compliant. The few products that are not RoHS are specified as such in the ordering information or in the specification tab.

ISO/IEC 17025:2017

The ISO/IEC 17025:2017 is given to calibration laboratories who have achieved the highest standards of quality, administration, and technical operations. Standing up to ISO/IEC 17025:2017 standard provides the opportunity for Ophir to serve as an international calibration laboratory. This accreditation gives customers full confidence that Ophir works according to the highest standards, and among other things it provides for technical competence of staff, validity of methods, proper calibration and maintenance of equipment, and many other areas. Full Scope of accreditation can be found on our website. Certain products are not under ISO/IEC 17025:2017 accreditation. Additional information is available in the specification sheet for each product.

3.1 Choosing a Beam Profiler

A laser beam profiler will increase your chance of success anytime you wish to design or apply a laser or when you find your laser system is no longer meeting specifications. You would never think of trying to build a mechanical part without a micrometer. So why attempt to build lasers or

laser systems with only a power meter? You will produce the desired results more quickly if you can measure basic things like beam width or size, beam profile and power.

We believe as Lord Kelvin said: "You cannot improve it if you cannot measure it".

3.1.1 Basic Questions

When choosing a laser beam profiler there are a plethora of choices to do the job, including CCD and CMOS cameras, scanning slit sensors, InGaAs and pyroelectric cameras, pinhole, and knife edge sensors to mention some. How does one decide which is the proper solution for one's application and from which company to obtain the profiler system? When making the selection there are four basic questions about the laser application that one must answer.

Wavelength?

The first question is: *What wavelength(s) do you intend to measure?* The answer to this question determines the type of detector needed, and what the most cost effective approach may be. For the UV and visible wavelength range from <193nm up to the very near infrared at around 1300nm, silicon detectors have the response to make these measurements. The largest number of cost effective solutions exist for these wavelengths including CCD cameras and silicon detector-equipped scanning aperture systems. Which of these is the best will be determined by the answers to the other three questions.

For the near infrared, from 800 to 1700nm, the choices become less abundant. In the lower end of this range from 800–1300nm the CCD cameras may still work, but InGaAs arrays become necessary above 1300nm. These are more expensive; four to five times the cost of the silicon CCDs. Scanning slit systems equipped with germanium detectors are still quite reasonably priced, within a few hundred dollars of their silicon-equipped cousins. At the mid and far infrared wavelengths the pyroelectric cameras and scanning slits sensors with pyroelectric detectors provide viable alternatives, again the best approach being determined by the answers to the subsequent questions.

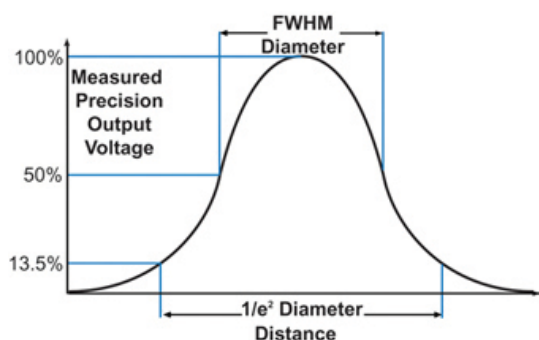

Beam Size?

The second question is: *What beam width or spot size do you wish to measure?* This question can also impact the profiler type choices. Arrays are limited by the size of their pixels. At the current state-of-the-art pixels are at best around 4µm for silicon arrays, and considerably larger, 30µm to 80µm with InGaAs and pyroelectric cameras. This means that a UV-NIR beam should be larger than 50µm or roughly 10 pixels in diameter to ensure that enough pixels are utilized to make an accurate measurement. Beams with spot sizes smaller than 50µm can be optically magnified or expanded to be measured with a camera. InGaAs camera pixels are around 30µm, limiting the minimum measurable beam size to 300µm; pyroelectric array pixels are even larger at 80µm, meaning the beams need to be at least 0.8mm to yield accurate results. Scanning slit profilers can measure with better than 3% accuracy beams that are four times the slit width or larger, putting the minimum beam sizes at around 8µm without magnification. Those investigators who want to measure their beams directly without additional optics could find this to be an advantage.

Power?

The third question is: *What is the power of the beam?* This determines the need for attenuation, and/or beam splitting, as well as the detector type. Array detectors, such as silicon CCD, CMOS, InGaAs and Pyroelectric cameras will usually need attenuation when measuring lasers. Scanning slit type profilers can measure many beams directly without any attenuation, due to the natural attenuation of the slit itself. Detector arrays and knife-edge profilers, by their nature, will allow the entire beam to impact the detector at some point in the measurement, leading to detector saturation unless the beam is appropriately attenuated. Lasers of any wavelength with CW powers above 100mW can be measured with the pyroelectric detector-equipped scanning slit profiler, making it the easiest profiler for many applications. Scanning slit profilers can directly measure up to kilowatts of laser power, depending on the spot size or power density.

CW or Pulsed?

The final question is: *Is the laser continuous wave (CW) or pulsed?* Lasers that operate pulsed at repetition rates less than ~10 kHz are best profiled with an array. Scanning

apertures cannot measure many beam sizes at this repetition rate effectively in real time. CW and pulsed beams with repetition rates above ~10 kHz can be measured with scanning slits if the combination of the repetition rate and the beam size are sufficient to have enough laser pulses during the transit time of the slits through the beam to obtain

One More Question

Besides these four questions about the physical nature of the laser to be measured, there is one more that needs to be asked: *How accurate does the measurement need to be?* Not all profilers or profiler companies are equal in this regard. Properly designed, maintained and calibrated camera and slit-based profilers can provide sub-micron precision for both beam width and beam position (centroid) measurements. A state-of-the-art CCD array with 4µm pixels can provide ±2% beam width accuracy for beams larger than 50µm. Accuracy for smaller beams may be worse due to the effects of insufficient resolution or pixilation. In addition, the effects of attenuation optics, noise and proper baseline zeroing or offset compensation can have dramatic impact on the accuracy of the measurement. Cameras that are not designed specifically for profiling may be much worse due to the presence of a cover glass and/or IR cut-off filter covering the array. These optical elements must be removed for laser profiling to prevent interference fringes or distortion of the beam being tested. Camera arrays provide a true two-dimensional picture of the beam and will show fine structure and hot and cold spots, which a slit will integrate out. Some applications do not require a map of the laser power distribution within the spot: spot size and spot location are sufficient. Other applications require that a careful mapping of the complete mode structure is made. These applications require 2D, array based sensors. The accuracy requirement is a question of what the data is to be used for. Accurate collimation or focus control requires the highest beam size accuracy. Checking the laser for hot spots, uniformity or beam shape dictates that the 2D sensor is employed and is as important as absolute size measurement accuracy.

How and where a profiler is to be used is also an important consideration in the equation. Profilers used by research and development scientists are often specialized. Ease-of-use and high throughput may be of no consequence if the purpose is to characterize specific optical systems that are well understood by the investigator. On the other hand, when a profiler needs to be used on the factory floor for quality assurance of the manufacturing process, ease-of-use, high throughput, and reproducibility become paramount. In this case the profiler requiring the least “fiddling” is generally the best fit. Here there is a competition between the intuitive and the ease-of-use. Some people find the 2-dimensional camera array to be the

a good profile. Knife-edge profilers are only able to measure CW beams. Pulsed beams have other considerations when selecting a beam profiling instrument, particularly pulse-to-pulse repeatability, and pulse-energy damage thresholds of the slit material or in the case of array detectors, beam sampling optics.

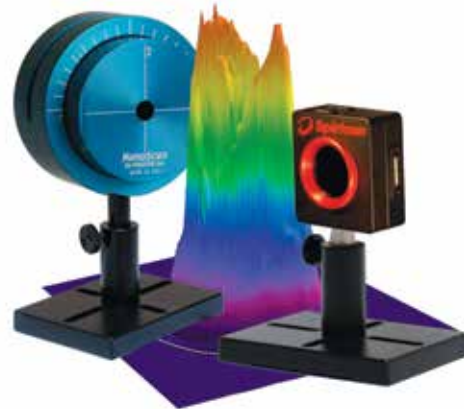

Slit-based Beam Profiler

Camera-based Beam Profiler

most intuitive, because they can relate to the idea of “taking a picture” of the laser beam; X-Y scanning slits may seem less intuitive. For any process that uses or works with CW or high frequency pulsed lasers the scanning slit will have the advantage of measuring the beam directly, possibly even at its focus point, without additional attenuation optics. The dynamic range of these systems is also broad enough to measure both the focused and the unfocused beam without changing the level of attenuation. Camera arrays, on the other hand will require attenuation adjustment.

Conversely, if the important aspect of the measurement is the two-dimensional image of the beam, or if the laser is pulsed at a low repetition rate, the array will be the solution; even if it means attenuation optics.

Also, many factory applications may want to ‘embed’ the beam profiler into a manufacturing cell or a piece of automation so the measurements and possibly pass/fail results are completed automatically. If so, look for a system that has this ability. Automation capability typically means the laser beam profile system communicates to other applications through LabView, Excel or .NET.

Whether choosing a camera or scanning slit system the user must first determine the laser beam measurement environment and what measurements are the most important to the success of the application. Ease of use and absolute spot size favors the scanning slit system while knowing about the hot and cold spots or the image of the beam under test, or any low repetition pulsed laser, requires a camera based beam profiling system. The assistance of knowledgeable product specialists is required to provide analysis of the measurement requirements of your laser application as well as to describe the features and benefits of available products.

3.1.2 Beam Profiler Finder

Finding the proper beam profiler and associated accessories to meet your beam profiling needs has never been easier. With our Beam Profiler Finder program just enter your laser parameters and the proper profilers for your application along with recommended accessories will be displayed on the screen. The program calculates the power and energy density capabilities of components, based on the laser wavelength, pulse length, repetition rate and other relevant parameters. It also compares all the other requirements such as the required aperture at every point based on the beam size, maximum and minimum power, energy etc. In addition to finding the right profiler solution for your application, the Beam Profiler Finder Program offers the following features:

- E mailing of report
- Calculation of input power and energy density and average power
- Tips on further action if no solution is found

Order of Selection

The sensors are selected in terms of cost effectiveness and ease of use, i.e. cost of the total solution balanced against ease of use and quality of profile.

Aperture

Since it is not practical to allow the beam to fill the entire aperture, the sensors are selected so that the sensor aperture is always at least 2mm or 10% larger than the beam and in the case of a Gaussian beam, 1.5 times the Gaussian beam diameter to insure that 99% of the beam is inside the aperture. If the beam is rectangular its corners may touch the aperture. The aperture is checked all along the beam path from the attenuators thru the beam expander / reducer and thru the camera.

Using the Beam Profiler Finder Program

The Beam Profiler Finder Program is available for use online on the Ophir website at the Beam Profiler section.

Beam Profiler Finder Input Screen

The screenshot shows the 'Beam Profiler Finder' input screen with the following details:

- Step 1 Measurement Type:** Beam Profile (selected), M Squared - Beam Propagation
- Step 2 Laser Beam Criteria:**
 - Laser:** Pulsed (selected)
 - Beam:** Gaussian (selected)
 - Measurement:** Average Only (selected)
 - Beam Parallel?:** Converging (selected)
- Step 3 Enter Laser Parameters:**
 - 1/e² Diameter at focusing lens (mm): 10
 - Wavelength: 1070 nm
 - Energy Range - Min to Max: 10 to 100 mJ
 - Distance From Lens to Focal Spot mm: 150
 - Focal Spot Diameter in μm : 60
 - Max Rep Rate: 10 Hz
 - Pulse Width: 7 s
- Step 4 Find Beam Profiler:**
 - Max. Power Density at Source W/cm²: 2.55
 - Max. Energy Density J/cm²: 0.25
 - Average Power W: 1

1. When the program is started, the above screen appears:
In Step 1, Select Measurement type :
"Beam Profile" or "M² - Beam Propagation".
2. In Step 2 select the laser type [CW or pulsed], the beam type [flat top or Gaussian and if flat top, circular or rectangular] and whether the beam is parallel, converging or diverging. If converging and you intend to measure the focal spot, you must input the beam size at the focusing lens and the distance from the lens to the focal spot. Note that a divergent beam is one typically from a LED or VECSEL.
Enter No if the beam is slightly divergent but basically parallel. Also, if the beam profiler cannot be inserted close to the focusing lens, enter the distance from nearest practical approach and the beam diameter at that point.
3. In Step 3, Enter the required laser parameters: beam diameter, wavelength, max/min power or max/min energy, rep rate and pulse width. If minimum power / energy is not entered, then the program assumes the minimum is 1/2 of the maximum.
4. In Step 4 click "Find Beam Profiler".

5. The combination of beam profilers and accessories that meet specified criteria will be listed in the output screen shown below. The input parameters are listed on top.

6. If you click on the light blue tinted items in the output, you will be sent to the appropriate web page on that item.
 7. To email the results, fill in your email and click Email.

Beam Profiler Finder Output Screen

Results For:

Power Only | Gaussian | $1/(e^{-2})$ Diameter at focusing lens 10mm | Energy Range 10mJ to 100mJ | Wavelength 1070nm | Rep Rate 10Hz | Pulse Width 7ns | Focal Length 150mm | Focal Spot Sizes 60um

#	Model	Description	Accessories Needed
1	SP920s or SP920G or LT665	Si camera standard	LBS300s-NIR-SP90466 Add 1 or 2 ND3 filter SPZ09253
2	SP907 or SP920s	Si Camera	X4 expander SPZ17022 or X6 expander SPZ09257 LBS300s-NIR-SP90466

Email results to: [Email](#)

If you want to measure the power or energy of your beam, use the sensor finder here

[Another Search?](#)

Power/Energy Sensors

In order to find a compatible power/energy sensor for your application, click on “here”.

Beam Propagation - M²

M Squared option enables user to choose equipment capable beam propagation analysis, including Beam Watch or BeamSquared and wide selection of lens to optimize measurement and provide accurate results.

Beam Profiler Finder Input Screen

Step 1 Measurement Type Beam Profile M Squared - Beam Propagation

Step 2 Laser Beam Criteria

Laser

CW

Pulsed

Beam Parallel?

Yes or divergence < 1°

Converging

Step 3 Enter Laser Parameters

Beam Diameter at beam Waist (mm) *

Wavelength * nm

Power Range - Min to Max * to mW

M²

Divergence Half angle mrad

Distance from Beam Waist to focusing Lens (mm) *

Step 4

[Find Beam Profiler](#)

Max. Power Density at Input W/cm2:

30.58

Max. Energy Density J/cm2:

0.00e+0

M Squared:

1.20

3.1.3 User Guide for Choosing the Optimum Beam Profiling System

Laser Wavelength	Power			Minimum Beam Size				
	<100mW	100mW-100W	>100W	<20µm	>20 <50µm	>50µm	>500µm	>1mm
UV-Vis	NS-Si	NS-Pyro		NS-Si/3.5/1.8	NS-Si/9/5	NS-Si/9/5	NS-Si /9/5	NS-Si /9/5
	SP932U/SP204S	SP932U/SP204S	NS-Pyro		NS-Pyro/9/5	NS-Pyro/9/5	NS-Pyro/9/5	NS-Pyro/9/5
			SP932U/SP204S			SP932U/SP204S	SP932U/SP204S	SP932U/SP204S
	SP402S	SP402S						
NIR 1000-1100nm	NS-Ge	NS-Pyro	SP402S			SP402S	SP402S	SP402s
	SP932U/SP204S	SP932U/SP204S	BW	NS-Ge/3.5/1.8	NS-Ge/9/5	NS-Ge/9/5	NS-Ge/9/5	NS-Ge/9/5
			NS-Pyro		NS-Pyro/9/5	NS-Pyro/9/5	NS-Pyro/9/5	NS-Pyro/9/5
	SP402S	SP402S	SP932U/SP204S			SP932U/SP204S	SP932U/SP204S	
Industrial & Additive								
Fiber		BW			BW	BW		
CO2	Pyrocam	Pyrocam						Pyrocam
Telecom and Eye-Safe 1100-1800nm	NS-Ge	NS-Pyro		NS-Ge/3.5/1.8	NS-Ge/9/5	NS-Ge/9/5	NS-Ge/9/5	NS-Ge/9/5
			NS-Pyro		NS-Pyro/9/5	NS-Pyro/9/5	NS-Pyro/9/5	NS-Pyro/9/5
						SP1203	SP1203	SP1203
						SP1201	SP1201	SP1201
	Pyrocam	Pyrocam	Pyrocam				Pyrocam	Pyrocam
1500-1600nm	NS-Ge	NS-Ge	NS-Ge	NS-Ge/3.5/1.8	NS-Ge/9/5	NS-Ge/9/5	Pyrocam	NS-Ge/9/5
							SP1203	SP203P
							SP1201	SP1203
	SP203P	SP203P	SP203P					SP1201
	LT665-1550	LT665-1550	LT665-1550				SP203P	
						LT665-1550	LT665-1550	
MIR & FIR	Pyrocam	NS-Pyro		Pyrocam w/ Beam Expansion	NS-Pyro/9/5	NS-Pyro/9/5	NS-Pyro/9/5	NS-Pyro/9/5
		Pyrocam	NS-Pyro				Pyrocam	Pyrocam
			Pyrocam					

Abbreviations:

FIR	Far Infrared	NIR	Near Infrared
Ge	Germanium	Si	Silicon
HP	High Power	SP	Indicates camera profiler
MIR	Mid-Infrared	NS	NanoScan
UV-Vis	Ultraviolet - Visible	BW	BeamWatch

Laser Wavelength	Minimum Beam Size		CW or Pulsed			Customer Priority				
	>5mm	>10mm	CW	Pulsed <1kHz	Pulsed >1kHz	Cost	2D/3D	No optics	Speed	Ease of use
UV-Vis	Pyrocam	NS-Pyro		Pyrocam w/ Beam Expansion	NS-Pyro/9/5	NS-Pyro/9/5	NS-Pyro/9/5	NS-Pyro/9/5	NS	NS
		Pyrocam	NS-Pyro				Pyrocam	Pyrocam		
			Pyrocam							
NIR 1000-1100nm			NS	SP932U/SP204S	SP932U/SP204S	SP932U/SP204S	SP932U/SP204S	NS	NS	NS
	BW		SP932U/SP204S					BW		
	SP402S	SP504S		SP402S	NS		SP402S			
		SP402S	SP402S		SP402S					
			BW							
Industrial & Additive										
Fiber	Pyrocam	Pyrocam	Pyrocam	Pyrocam	Pyrocam	NS/Pyrocam	Pyrocam	NS/Pyrocam	Pyrocam	Pyrocam
CO2								NS/Pyrocam		
Telecom and Eye-Safe 1100-1800nm				SP1203	SP1203		SP1203			
				SP1201	SP1201		SP1201			
			NS			NS		NS	NS	NS
					NS		Pyrocam			
	Pyrocam									
1500-1600nm					NS					
			SP1203	SP1203	SP1203					
			SP1201	SP1201	SP1201					
	SP203P	LT665-1550				SP203P	SP203P	NS	NS	NS
	LT665-1550			LT665-1550	LT665-1550		LT665-1550			
MIR & FIR			NS	Pyrocam	NS	NS	Pyrocam	NS	NS	NS
	Pyrocam		Pyrocam		Pyrocam					

Abbreviations:

FIR	Far Infrared	NIR	Near Infrared
Ge	Germanium	Si	Silicon
HP	High Power	SP	Indicates camera profiler
MIR	Mid-Infrared	NS	NanoScan
UV-Vis	Ultraviolet - Visible	BW	BeamWatch

3.2 Benefits of Beam Profiling

You can get more out of your laser

- Figure 1 shows an industrial Nd: YAG laser, near Gaussian beam, with 100 Watts output power and 1.5kW/cm² power density. Figure 2 is the same Nd: YAG beam at greater power, 170 Watts, but it split into 2 peaks producing only 1.3kW/cm² power density. The power density of the beam decreased 13% instead of increasing by the 70% expected. Without measuring the beam profile and beam width, you would not know what happened to your power density, and why the performance did not improve.

Laser cavities become misaligned

- Figures 3 & 4 are beam profiles of CO₂ lasers used for ceramic wafer scribing in the same shop. The second laser with the highly structured beam produced mostly scrap parts, until the laser cavity was aligned.

Off axis delivery optics

- Figures 5 & 6 show an industrial Nd:YAG laser with misaligned turning mirror, before and after adjustment.

Alignment of devices to lenses

- Figures 7 & 8 show beam profiles during alignment of a collimating lens to a laser diode. The first profile shows poor alignment of the lens to the diode, which can easily be improved when seeing the profile in real time.

Laser amplifier tuning

- Figures 9 & 10 show a Cr:LiSAF femtosecond laser oscillator beam with a near Gaussian output, and what happens to the oscillator beam with poor input alignment.

All these examples illustrate the need for beam monitoring

- If the beam has problems, you must (or should) measure the beam and you must (or should) see the profile of the beam to make corrections.
- Most laser processes can be improved
- Scientific experiments can be more accurate
- Commercial instruments can be better aligned
- Military devices can have greater effectiveness
- Industrial processing produces less scrap
- Medical applications are more precise

Just knowing the beam profile can make the difference between success and failure of a process.

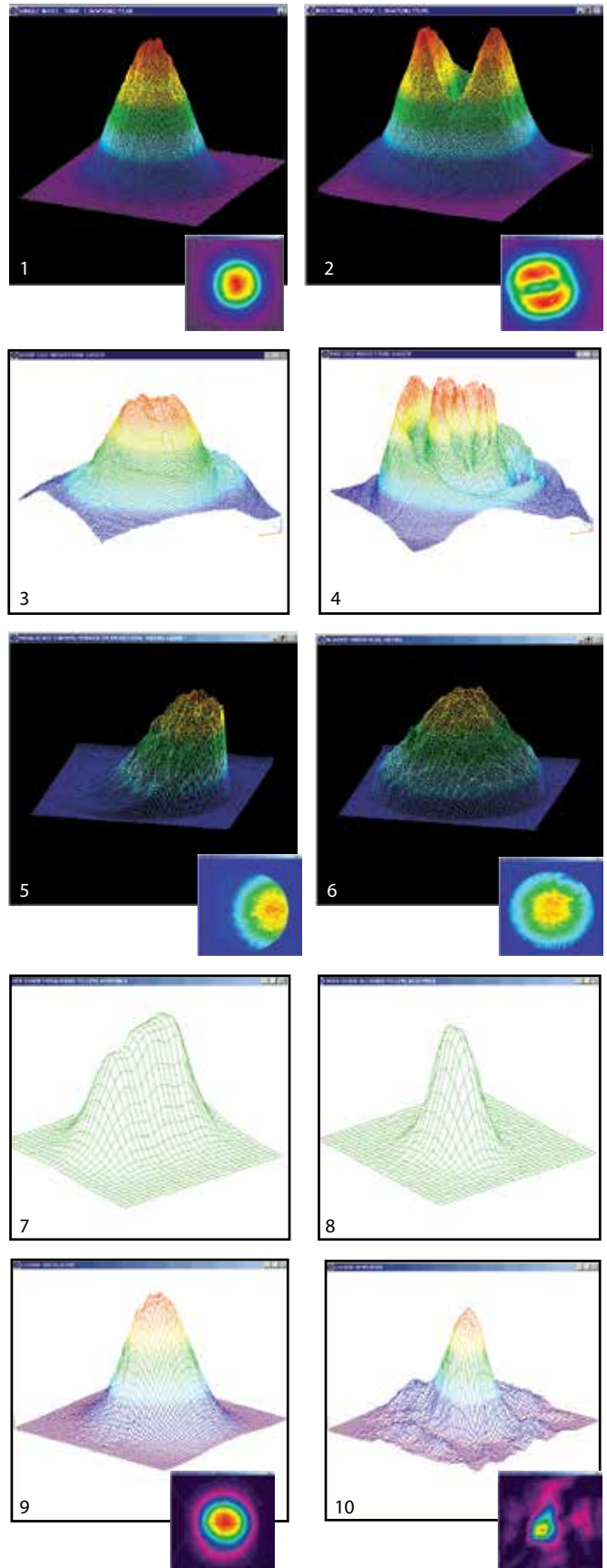

3.3 Introduction to Camera-Based Profilers

Beam Attenuating Accessories

A camera-based beam profiler system consists of a camera, profiler software and a beam attenuation accessory. Spiricon offers the broadest range of cameras in the market to cope with wavelengths from 13nm, extreme UV, to 3000 μm , in the long infrared. Both USB and GigE interfaces are available for most wavelength ranges providing flexibility for either laptop or desktop computers.

BeamGage®, the profiling software, comes in two versions: Standard and Professional. Each builds off of the next adding additional capability and flexibility needed for adapting to almost any configuration requirement. Spiricon also has the most extensive array of accessories for beam profiling. There are components for attenuating, filtering, beam splitting, magnifying, reducing and wavelength conversion. There are components for wavelengths from the deep UV to CO₂ wavelengths. Most of the components are modular so they can be mixed and matched with each other to solve almost any beam profiling requirement needed.

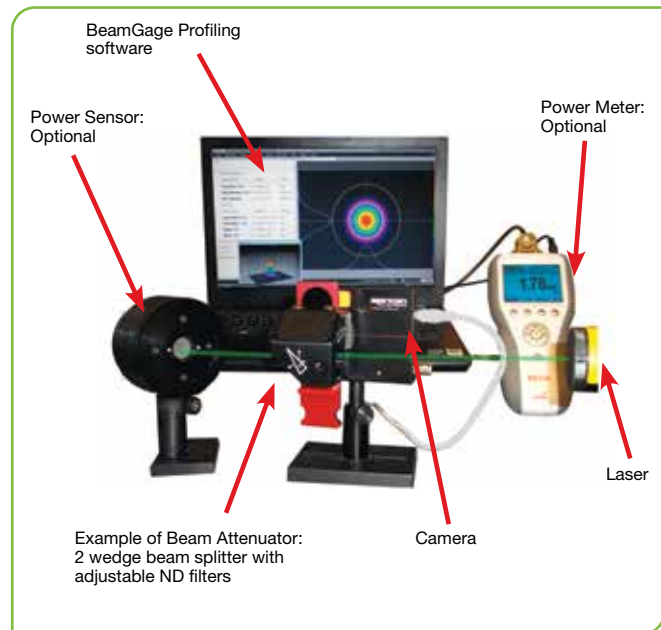

Acquisition and Analysis Software

The BeamGage software is written specifically for Microsoft Windows operating systems and takes full advantage of the ribbon-base, multi-window environment. The software performs rigorous data analyses on the same parameters, in accordance with the ISO standards, providing quantitative measurement of numerous beam spatial characteristics. Pass/Fail limit analysis for each of these parameters can be also applied.

- ISO Standard Beam Parameters
- Dslit, Denergy, D4 σ
- Centroid and Peak location
- Major and Minor Axis
- Ellipticity, Eccentricity
- Beam Rotation
- Gaussian Fit
- Flat-top analysis / Uniformity
- Divergence
- Pointing stability

For data display and visualization, the user can arrange and size multiple windows as required. These may contain, for example, live video, 2D Topographic and 3D views, calculated beam parameters and summary statistics in tabular form with Pass/Fail limit analysis, and graphical strip chart time displays with summary statistics and overlays. Custom configured instrument screens with multiple views can be saved as configuration files for repeated use. Data can be exported to spreadsheets, math, process/instrumentation and statistical analysis programs, and control programs by logging to files or COM ports, or by sharing using LabView or ActiveX Automation.

- Video Dual Aperture Profiles
- Beam Statistics
- 3D Profile View
- 2D Topographic View
- Time Statistics Charts
- Pointing / Targeting
- Hide measurements and features not in use for user simplicity
- Notes

3.3.1 BeamGage®-Standard Version

- Extensive set of ISO quantitative measurements
- Patented Ultracal™ algorithm for highest accuracy measurements in the industry
- Customizable user interface for 'ease of use'
- Auto-setup and Auto-exposure capabilities for fast set-up and optimized accuracy
- Statistical analysis on all calculated results displayed in real time
- New BeamMaker® beam simulator for algorithm self-validation

The performance of today's laser systems can strongly affect the success of demanding, modern laser applications.

The beam's size, shape, uniformity or approximation to the expected power distribution, as well as its divergence and mode content can make or break an application. Accurate knowledge of these parameters is essential to the success of any laser-based endeavor. As laser applications push the boundaries of laser performance it is becoming more critical to understand the operating criteria.

For over thirty years Ophir-Spiricon has developed instruments to accurately measure critical laser parameters. Our LBA and BeamStar software have led the way. Now with the introduction of BeamGage, Ophir-Spiricon offers the first "new from the ground up" beam profile analysis instrument the industry has experienced in over 10 years.

BeamGage includes all of the accuracy and ISO approved quantitative results that made our LBA software so



successful. BeamGage also brings the ease-of-use that has made our BeamStar software so popular. Our patented UltraCal algorithm, guarantees the data baseline or "zero-reference point" is accurate to 1/10 of a digital count on a pixel-by-pixel basis. ISO 11146 requires that a baseline correction algorithm be used to improve the accuracy of beam width measurements. UltraCal has been enhanced in BeamGage to assure that accurate spatial measurements are now more quickly available.

See Your Beam As Never Before:

The Graphical User Interface (GUI) of BeamGage is new. Dockable and floatable windows plus concealable ribbon tool bars empowers the BeamGage user to make the most of a small laptop display or a large, multi-monitor desktop PC.

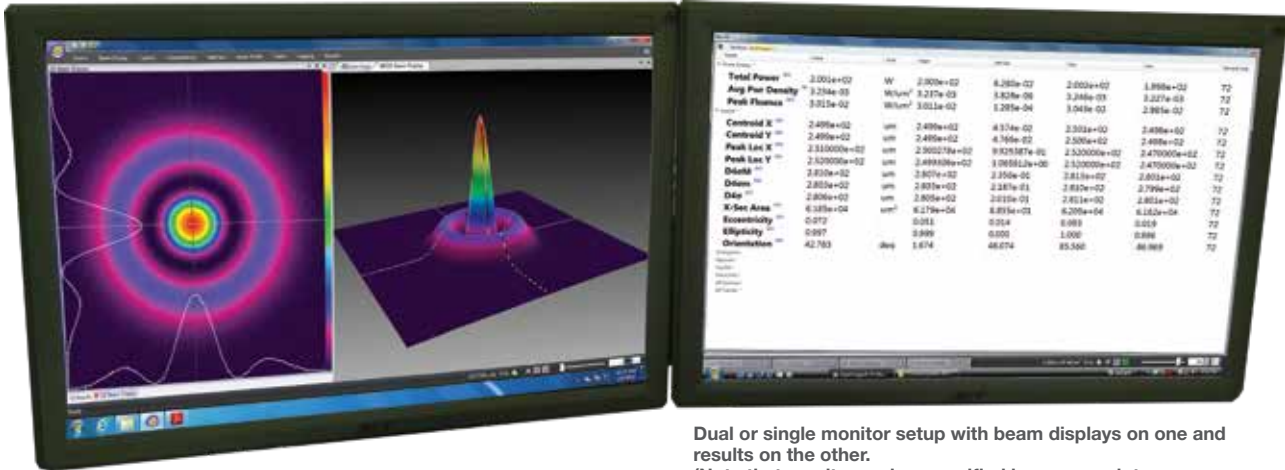

Dual or single monitor setup with beam displays on one and results on the other. (Note that results can be magnified large enough to see across the room).

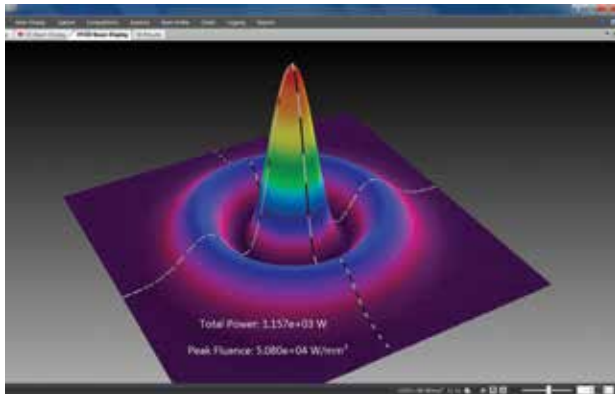

Beam only (Note results overlaid on beam profile).

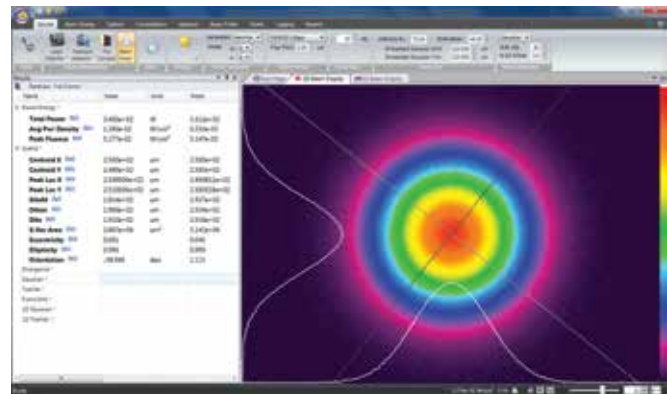

Beam plus results

- 3D displays Rotate & Tilt. All displays Pan, Zoom, Translate & Z axis Zoom

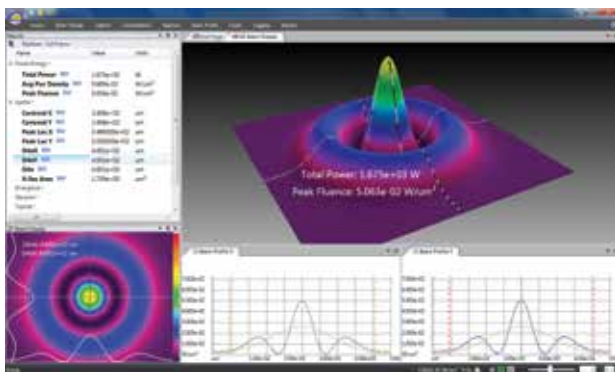

Multiple beam and results windows. (Note quantified profile results on 3D display & quantified 2D slices).

Measure Your Beam As Never Before:

Ultracal: Essential, or no big deal?

If you want accurate beam measurements, you want Ultracal.

What is Ultracal?

Our patented, baseline correction algorithm helped establish the ISO 11146-3 standard for beam measurement accuracy. The problems with cameras used in beam profile measurements are: a) The baseline, or zero, of the cameras will drift with time and temperature changes, and b) include random noise. Ultracal is the only beam profiler algorithm that sets the baseline to “zero”, and, in the center of the noise. (Competitive products use other less sophisticated algorithms that perform a baseline subtraction, but truncate the noise below the “zero” of the baseline. This leaves only a “positive” component, which adds a net value to all beam measurements).

Try the following on any other beam profiler product to see the inherent error if you don't use Ultracal.

1. Measure a beam with full intensity on the profiler camera.
2. Insert a ND2 filter (100X attenuation) into the beam and measure it again.
3. Compare the results.
4. The Standard Deviation on the right is about 3%, which is phenomenal compared to the 100% or more of any beam profiler without Ultracal. Adding the use of Automatic Aperture improves the accuracy to 1%. (The conditions of this measurement is a camera with a 50dB SNR).
5. You normally don't make measurements at such a low intensity. But occasionally you may have a drop in intensity of your beam and don't want to have to adjust the attenuation. Or, you may occasionally have a very small beam of only a few tens of pixels. In both of these cases, Ultracal becomes essential in obtaining accurate measurements.

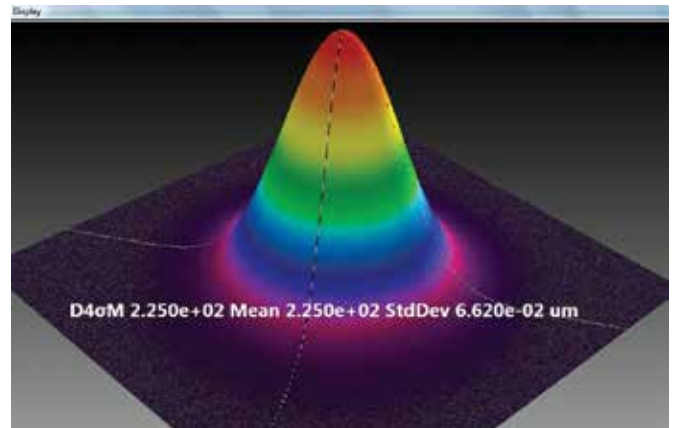

Beam at full intensity, Width 225 μ m, Std Dev 0.06 μ m

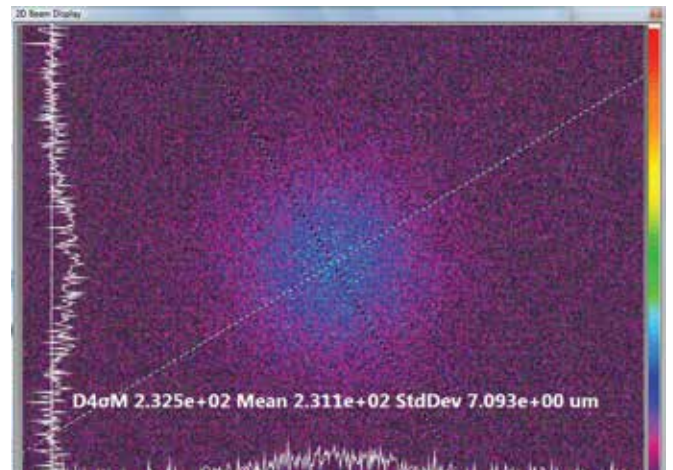

Beam attenuated 100X (displayed here in 2D at 16X magnitude zoom), Width 231 μ m, Std Dev 7 μ m

Beam Measurements and Statistics

BeamGage allows you to configure as many measurements as needed to support your work, and comes standard with over 55 separate measurement choices. To distinguish between calculations that are based on ISO standards and

those that are not, a graphical ISO logo is displayed next to appropriate measurements. You can also choose to perform statistical calculations on any parameter in the list.

Name	Value	Units
Spatial *		
Centroid X ISO	3.121e+00	mm
Centroid Y ISO	3.121e+00	mm
Peak Loc X ISO	3.100000e+00	mm
Peak Loc Y ISO	3.125000e+00	mm
D4σ ISO	4.449e+00	mm
D4σ ISO	4.406e+00	mm
Dkσ 10/90	3.778e+00	mm
Dkσ 10/90	3.685e+00	mm
Dkσ 16/84 ISO	3.477e+00	mm
Dkσ 16/84 ISO	3.368e+00	mm
D%pkM	2.714e+00	mm
D%pkm	2.594e+00	mm
X-Sec Area ISO	1.540e+01	mm ²
Eccentricity ISO	0.138	
Ellipticity ISO	0.990	
Divergence *		
Gaussian *		
Gauss Centroid X	3.125039e+00	mm
Gauss Centroid Y	3.124977e+00	mm
Goodness of Fit	0.694	
Roughness of Fit	0.217	

Small sample of possible measurements out of a list of 55

Name	Value	Units	Mean	Std Dev	Max	Min	Sample Size
Power/Energy *							
Total Power ISO	2.809e+02	W	2.809e+02	4.096e-02	2.810e+02	2.808e+02	248
Peak Fluence ISO	8.105e+01	W/mr	8.111e+01	1.558e-01	8.170e+01	8.073e+01	248
Efficiency ISO	---	%	---	---	---	---	---
% in Aperture	100.00	%	100.00	0.00	100.00	100.00	248
Spatial *							
Centroid X ISO	3.122e+00	mm	3.121e+00	2.820e-04	3.122e+00	3.121e+00	262
Centroid Y ISO	3.122e+00	mm	3.121e+00	2.683e-04	3.122e+00	3.121e+00	262
Peak Loc X ISO	3.125000e+00	mm	3.124046e+00	2.578e-02	3.200000e+00	3.050000e+00	262
Peak Loc Y ISO	3.125000e+00	mm	3.128721e+00	2.567e-02	3.200000e+00	3.075000e+00	262
D4σ ISO	4.451e+00	mm	4.450e+00	1.176e-03	4.454e+00	4.435e+00	1.733
D4σ ISO	4.406e+00	mm	4.407e+00	1.208e-03	4.421e+00	4.403e+00	1.733
Dkσ 10/90	3.767e+00	mm	3.770e+00	5.985e-03	3.788e+00	3.750e+00	262
Dkσ 10/90	3.674e+00	mm	3.676e+00	6.629e-03	3.695e+00	3.653e+00	262
Eccentricity ISO	0.141		0.139	0.003	0.147	0.132	262
Ellipticity ISO	0.990		0.990	0.000	0.991	0.989	48
Divergence *							
Gaussian *							
TopHat *							
Frame Info *							
1D Gaussian *							
1D TopHat *							

Sample of calculation results with statistics applied

Multiple Charting Options

You can create strip charts for stability observations on practically any of the calculations options available. Charts enable tracking of short or long term stability of your laser.

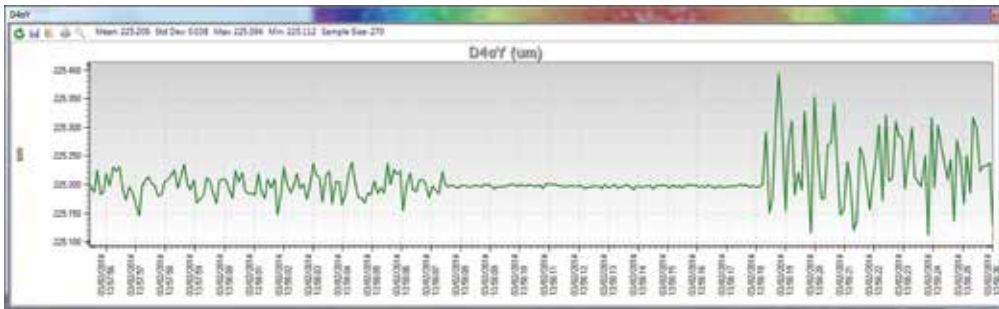

Strip chart of beam D4sigma width. Note how changing conditions affects the width repeatability. Beam intensity changed over 10db, making noise a significant factor in measurement stability.

Beam Pointing Stability

Open the Pointing Stability Window to collect centroid and peak data from the core system and display it graphically. View a chart recorder and statistical functions in one interface:

Peak location scatter plot with histogram color-coding.

Set a sample limit, and specify the results items to graph on the strip chart.

The radius is referenced from either an Origin established in BeamGage or from the continuously calculated Average Centroid position.

A centroid location scatter plot with histogram color-coding.

A pointing stability strip chart presents data over time for the Centroid X and Y, Peak X and Y and centroid radius from an origin or from the mean centroid.

Easy to Use and Powerful

BeamGage is the only beam profiler on the market using modern Windows 7 navigation tools. The menu system of BeamGage is easy to learn and easy to use with most controls only one mouse click away. Some ribbon toolbar examples:



Some of the Beam Display options (Display access options under the Tools tab on the left).

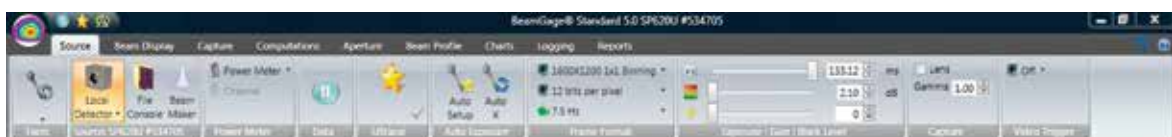

Some of the Beam Capture options.

BeamGage Main Display Screen

File Save/Load ApplicationButton

Quick Access Toolbar for common tasks

Tabbed Control Access

2D Beam Display

Tool Windows that dock inside or float outside App

User Definable Window Layout

Integrated Help System

Beam Results With Statistics

ISO Compliant Results

1D Profiling Options

Cursors With Power / Energy Readouts

Processing Status Indicators

3D Beam Display

Buffered Video Scrolling Controls

Pass / Fail with Password Protection for Production Testing

BeamGage allows the user to configure the displayed calculations; set-up the screen layout and password protect the configuration from any changes. This permits secure product testing as well as data collection for Statistical Process Control (SPC), all while assuring the validity of the data.

Failures (or successes) can be the impetus for additional actions including a TTL output signal or PC beep and the termination of further data acquisition.

Name	Value	Mean	Std Dev	Max	Min	Units
Power/Energy *						
Spatial *						
Centroid X ISO	7.831e+01	7.831e+01	2.849e-03	7.832e+01	7.830e+01	um
Centroid Y ISO	7.965e+01	7.965e+01	3.047e-03	7.966e+01	7.964e+01	um
Peak Loc X ISO	7.000000e+01	7.073199e+01	1.340173e+0	7.500000e+01	6.700000e+01	um
Peak Loc Y ISO	7.100000e+01	7.183659e+01	1.333245e+0	7.500000e+01	6.800000e+01	um
D4σX ISO	1.238e+02	1.238e+02	8.334e-03	1.239e+02	1.238e+02	um
D4σY ISO	124.041	124.053	0.008	124.079	124.027	um
D4σ ISO	1.239e+02	1.239e+02	6.395e-03	1.240e+02	1.239e+02	um

Unique Features of BeamGage - Standard

Power/Energy Calibration

Using the USB or GigE output from select Ophir power/energy meters, the BeamGage application will display measured power/energy values from the full range of Ophir thermopile, photodiode and pyroelectric sensors. Pulsed lasers can be synced up to 100Hz, or the frame rate of the triggered camera, whichever is less. This is the first time in the industry a laser power meter has been married to a laser beam profile system.



BeamGage is the only product to integrate profiling and power meter measurements

BeamMaker®; Numerical Beam Profile Generator

BeamGage contains a utility, BeamMaker, that can synthetically generate beam profile data by modeling either Laguerre, Hermite or donut laser beams in various modal configurations. BeamMaker permits the user to model a beam profile by specifying the mode, size, width, height, intensity, angle, and noise content. Once generated the user can then compare the theoretically derived measurements to measurements including experimental inaccuracies produced by the various measurement instruments and environmental test conditions.

Users can now analyze expected results and confirm if measurement algorithms will accurately measure the beam even before the experiment is constructed. BeamMaker can help laser engineers, technicians and researchers understand a beam's modal content by calculating results on modeled beams for a better understanding of real laser beam profiles. BeamMaker is to laser beam analysis as a function generator is to an oscilloscope.

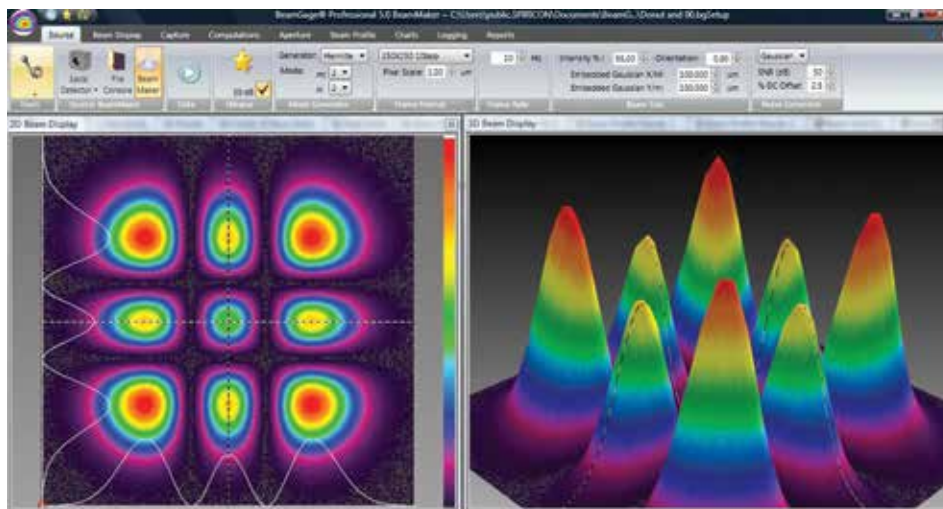

BeamMaker producing a synthetically generated Hermite TEM_{22} beam and displayed in both 2D and 3D

Integrated automatic Help linked into the Users Guide

Touch sensitive Tool tips are available on most all controls, and "What's This" help can provide additional details. Confused about what something is or forgot how it works, just go to the top right corner and touch the "What's This"

help icon, then click on the control or menu item that you want more info about and you are taken to the explanation within the BeamGage Users Guide.

Multilingual

BeamGage comes with both Japanese and Chinese user interface. Country specific manuals can be downloaded from the ophiropt.com/photronics web site.

3.3.2 BeamGage®-Professional Version

Professional is an upgrade version of BeamGage-Standard that has all of the BeamGage-Standard features plus additional functionality.

Image Partitioning

Partitioning allows the user to subdivide the camera image into separate regions, called partitions, and compute separate beam results within each partition. When using partitioning special results items can be displayed that relate to delta values between the computed centroids or peaks

of each partition. Partitioning is useful to enable separate analysis of individual beams when multiple beams impinge on the camera simultaneously. This feature is particularly useful when analyzing multiple fibers in a single bundle.

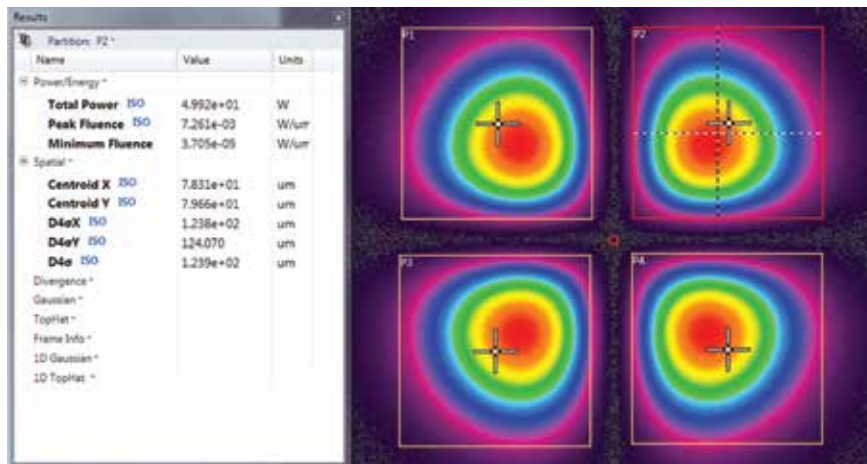

Shown is an example of the results for partition P2 and its related display frame. Observe that the selected partition is highlighted in RED. The crosshair in each partition is user controlled. The crosshair can be moved to a new position with the mouse or can be numerically positioned using the expanded controls that appear when a partition is created.

Automation Interface

BeamGage Professional provides an automation interface via .NET components to allow customers the ability to build custom applications that incorporate the laser beam analysis and processing power of BeamGage. The BeamGage automation interface allows developers to control BeamGage programmatically via a set of "puppet strings" known as the automation interface. The automation interface was developed to provide the ability to base control decisions for a second application on results and behaviors recognized by BeamGage. With this ability users can quickly

and efficiently meet their manufacturing/analysis goals with minimum human interaction.

The automation interface was designed to achieve two main goals. First, to allow the BeamGage user to programmatically do what they could otherwise do via the graphical user interface (GUI). Second, to expose stable interfaces to the user that will not change, causing breaks to their dependent code. Interface examples for LabVIEW, Excel and .NET VB are included.

Custom Calculations

If BeamGage-Standard does not have the measurement you need the Professional version permit the user to program-in their own set of calculations. User defined computations are treated the same as other BeamGage standard calculations.

An example of a customer generated custom equation.

These custom results are displayed on the monitor, logged with results, and included on hard copy print-outs as if they were part of the original application.

$$S = \frac{1}{\pi^2} \left| \int_0^{2\pi} \int_0^1 \exp(2\pi i \Delta W(\rho, \theta)) \rho d\rho d\theta \right|^2$$

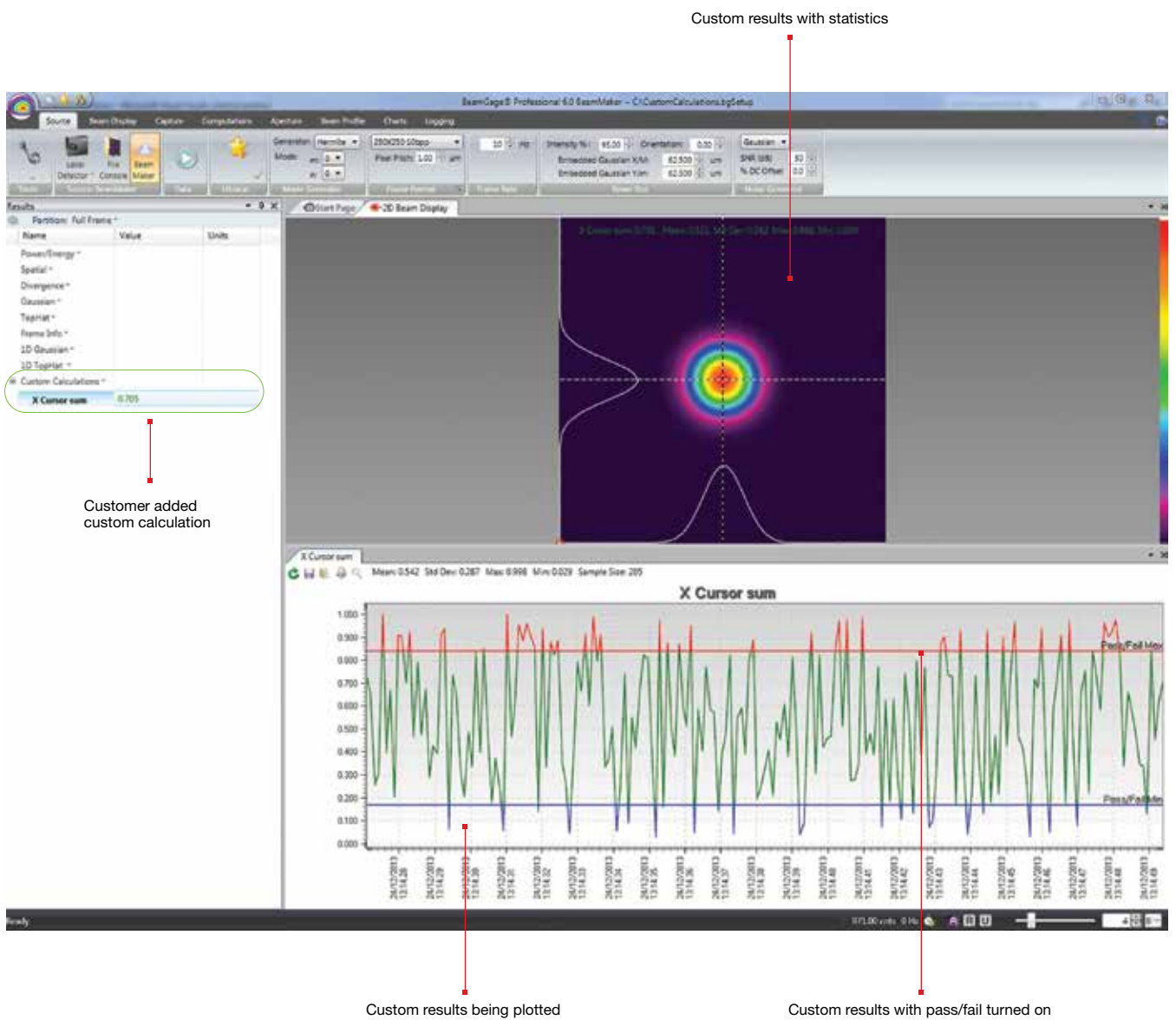

3.3.3 Software Comparison Chart

Features	BeamGage® Standard	Upgrade to BeamGage® Professional to include: (all features in Standard plus)
Features Overview	User selectable for either best “accuracy” or “ease of use”	
	Supports our patented Ultracal algorithm plus Auto-setup and Auto-exposure capabilities	
	Extensive set of ISO quantitative measurements	
	Support for USB, GigE and Pyrocam™ IIIHR and Pyrocam™ IV cameras	Supports InGaAs and large format SP504S cameras
	New Beam Maker® beam simulator for algorithm self validation. See below for more detailed description	
	Simultaneous 2D and 3D displays	
	Multi-instance, multi-camera use	
	Results synchronized to select models of Ophir power/energy meters. Supported products include: Vega, Nova II, Pulsar and Juno, in both 32 and 64bit OS. (Quasar is not supported)	
	Supports Satellite windows on multiple monitors	
	Continuous zoom scaling in both 2D and 3D	
		Window partitioning to allow analysis of multiple beams from a single camera image
	Camera ROI support on USB and GigE cameras	
	Manual and Auto-aperturing to reduce background effects	
	Pass/Fail on all results items, w/multiple alarm options	
	Beam Pointing Stability scatter plot and stripchart results	
	Full featured logging capabilities in a reloadable industry standard data file format	
	Configurable Report Generator that allows cut and paste of results, images and settings	
		.NET Automation interface that allows for remote control. Examples in Python, LabView, Excel and .Net VB
	Supports English, German, Japanese and Chinese Windows 7 (64), Windows 10 and Windows 11	
	Multilingual GUI in English, Japanese and Chinese	
	Administrator can lock software options for non-administrators	
Quantitative Calculations; Basic Results	(per ISO 11145, 11146-1/-3, and 13694	
Power/Energy Results	Total power or energy (Can be calibrated or sync'd to an external Ophir power/energy meter)	
	Peak power/energy density	
	Min. Fluence	
	Average pulse power	
	Peak pulse power	
	Device efficiency	
	% in Aperture	
Spatial Results	Peak and Centroid locations	
	Beam width	
	• Second Moment (D4s)	
	• Knife Edge 90/10	
	• Knife Edge (User selectable level)	
	• Percent of Peak (User selectable)	
	• Percent of Total Energy (User selectable)	
	• Encircled power smallest slit @ 95.4	
	• Moving slit (User selectable)	
	Beam diameter	
	• Average diameter (based on x/y widths)	
	• Second Moment (D4s)	
	• Encircled power smallest aperture 86.5	
	• Encircled power smallest aperture (User selectable level)	
	Elliptical Results	
	• Elliptical orientation	
	• Ellipticity	
	• Eccentricity	
	Distance Measurement	
	• Cursor to Crosshair	
	• Centroid to Crosshair	
	Area Results	
	Beam cross-sectional area	

Features	BeamGage® Standard	Upgrade to BeamGage® Professional to include: (all features in Standard plus)
Divergence	Focal Length method Far-field two-point method Far-field Wide Angle method	
Gaussian Fit	2D whole beam fits 1D line fits Height Width X/Y Centroid Goodness of fit Roughness of fit	
Tophat Results	2D and 1D Flatness Effective Area Effective Power/Energy Fractional Effective Power/Energy Effective Average Fluence Uniformity Plateau Uniformity Edge Steepness 1D or 2D surface inclination	
Other Quantitative Items	Frame Averaging Frame Summing Frame Reference Subtraction Image Convolution Camera signal/noise calculator Row and Column summing with results loggable	
Beam Stability Displays and Results	(per ISO 11670) Pointing Stability of Centroid <ul style="list-style-type: none"> • Scatter Plot display w/histogram • Mean Centroid • Azimuth angle of the scatter • Stability (M'/m'/S) • Max Radius • X/Y centroid/peak Strip chart plots • Sample/Time controlled • Pass/Fail limits • Auto scaling • Beam Width/Diameter Strip Charts with Results • X/Y M/m beam widths plots • Beam Diameter plot • Mean/Std Dev/Min/Max results displayed • Power/Energy Strip Charts • Total Power/Energy plot • Peak fluence plot • Avg Power plot • Elliptical Results Strip Chart • Elliptical orientation plot • Ellipticity plot • Eccentricity plot • Mean/Std Dev/Min/Max results displayed 	Scalable Intensity Histogram, exportable X or Y axial off axis image correction
Custom Calculations		User can program-in own set of calculations
Beam Profile Display Options	Utilizes advanced hardware accelerated graphics engines. All display windows can be satellited to utilize multiple display monitors. Can open one each simultaneous 2D and 3D beam display windows Common color palette for 2D and 3D displays Can open X and/or Y 1D beam slice profiles overlaid onto the 2D or 3D displays or in separate windows Continuous software zooming in both 1D, 2D and 3D displays Pan to any detector location Continuous Z axis display magnitude scaling Multiple 128 color palettes user selectable Results items can be pasted into 2D, 3D, 1D, Pointing stability or Chart display windows.	
		Able to partition the camera imager into multiple regions with separate results.

Features	BeamGage® Standard	Upgrade to BeamGage® Professional to include: (all features in Standard plus)
1D Features	Available overlaid with 2D and 3D or in separate windows	
	X any Y plots on separate or combined displays	
	1D displays with basic results and column row summing option	
	Tophat 1D displays with Tophat results	
	Gaussian 1D displays with Gaussian fit results	
2D Features	1D Profile display of the Gauss fit results on 1D, 2D and 3D displays	
	Continuously zoomable and resizable displays in satellitable window	
	Continuous Z axis display magnitude scaling	
	Zoomable to subpixel resolution for origin and cursor placements	
	Pixel boundaries delineated at higher zoom magnifications	
	Adjustable Cursors that can track peak or centroid	
	Adjustable Crosshairs that can track peak or centroid	
	Adjustable manual apertures	
	Viewable Auto-aperture placement	
	Displayed beam width marker	
	Integrated Mouse actuated pan/zoom controls	
	Separate 2D pan/zoom window to show current view in 2D beam display	
	Manual or fixed origin placement	
		Ability to create partitions using the manual aperture controls
3D Features	3D graphics utilize solid surface construction with lighting and shading effects	
	Integrated Mouse actuated pan/zoom/tilt/rotate controls	
	Selectable Mesh for drawing speed vs resolution control	
	Continuously zoomable and resizable displays in satellitable window	
	Continuous Z axis display magnitude scaling	
Partitioning	User enabled backplanes with cursor projections	
		Users can subdivide the imager into separate beam measurement regions. All enabled results are computed inside of each partition
		The manual aperture is used to define and create rectangular partition
		When partitioning is enabled some new results items will be enabled
Statistical Analysis		Centroid measurements between beams in each partition can be performed
		Partitioned imagers must have a single origin common to all partitions. All coordinate results are globally referenced to this single origin
	Performed on all measurement functions with on-screen display	
	• Choices of intervals	
	• Manual start/stop	
	• Time from 1 second to 1000 hours	
File types	• Frames from 2 to 99,999 Measurements reported	
	• Current frame data, Mean, Standard Deviation, Minimum, Maximum of each calculation performed	
	Controls integrated with beam stability results, scatter and strip chart plots	
	Industry Standard HDF5 data and setup file format which are compatible in third party applications such as MatLab and Mathematica	
	Math program and Excel compatible ASCII-csv results files	
Printing	Graphics in jpg file format	
	Legacy file Compatibility with LBA formats	
	A user defined single file output that can contain settings, beam displays, beam profiles, charts, results, etc. in either .pdf or .xps file formats	
Pass/Fail	Images, reports, results, graphs, charts, statistics and setup information	
	Option to print many frames in a single operation	
Pass/Fail	WYSIWYG images	
	Set Maximum/Minimum limits on all calculations and statistics	
	Red/Green font color indication on result items	
	Multiple choices for indication of failed parameters, including TTL pulse for external alarm	
	Master pass/fail which triggers alarm on any failure	
	USB/GigE signal, beep, stop, and log alarm options	

Features	BeamGage® Standard	Upgrade to BeamGage® Professional to include: (all features in Standard plus)	
Logging	Video Data Logging Formats: HDF5, ASCII-csv		
	Results in ASCII-csv		
	Pictures 2D and 3D in jpg, gif, tiff, bmp, png file formats		
	Charts in ASCII-csv		
	Cursor Data in ASCII-csv		
	Row/Column summed in ASCII-csv		
	Continuous Logging		
	Time Interval Logging		
	Frame Count Logging		
	Periodic Sampling		
	Pass/Fail Sampling		
	Burst Sampling, after a user specified time interval, sample a user specified number of frames		
	Exporting	Convert frame buffer data to third party format	
		Export a user specified number of frames from the buffer	
Export Image Data: ASCII-cvs			
Export Results: ASCII-csv			
Export Picture: jpg, gif, tiff, bmp, png file formats supported			
Export Cursor Data: ASCII-cvs			
Export Row/Column summed: ASCII-cvs			
Automation Interface (.NET)	Export Image Data in Aperture		
		Automation Interface with examples in LabVIEW, Excel and Net VB	
		Automate launch and termination of the application	
		Automate start, stop, Ultracal, Auto-X and Auto Setup	
		Automate the loading of application setups	
		Automate control of most camera settings	
		Automate a subset of the application features and controls	
Integrated Help	PDF Operators Manual	Automate the capture of Binary Video Data	
	Context Sensitive (Whats this?) Help	Automate the acquisition of application results	
	Context Sensitive Hints	Automate the acquisition of application Images	
Signal Conditioning for Enhanced Accuracy	Spiricon's patented Ultracal enables more accurate beam measurement and display. Ultracal takes a multi-frame average of the baseline offset of each individual pixel to obtain a baseline accurate to approximately 1/8 of a digital count. This baseline offset is subtracted from each frame, pixel by pixel, to obtain a baseline correction accurate to 1/8 digital count. Spiricon's Ultracal method retains numbers less than zero that result from noise when the baseline is subtracted. Retaining fractional and negative numbers in the processed signal can increase the beam width measurement accuracy by up to 10X over conventional baseline subtraction and clip level methods. Spiricon's Ultracal conforms to the best method described in ISO 11146-3:2004		
Frame Averaging	Up to 256 frames can be averaged for a signal-to-noise ratio, S/N, improvement of up to 16X (Noise is averaged up to 1/256th [8 fractional bits]). Data is processed and stored in a 32bit format		
Frame Summing	Up to 256 frames can be summed to pull very weak signals out of the noise		
Convolution (Adjacent Pixel Averaging)	Due to the precise nature of Ultracal baseline setting, (i.e., a retention of both positive and negative noise components) summing of frames can be performed without generating a large offset in the baseline		
Beam Maker®	Choice of 5 convolution algorithms for spatial filtering for both display and calculations. Spatial filtering improves the visual S/N		
	Beam Maker is a new feature that allows the user to model both Laguerre-Gaussian and Hermite-Gaussian laser beams in various modal configurations. With these models you have verification and validation tools that allows not only OSI but also the end user to verify BeamGage's basic beam width measurement algorithms. It can also be used to model laser beams with special input conditions such as signal-to-noise, background offset, and bits per pixel resolution. This allows the user to better understand the accuracy of measurements made under both optimum and adverse conditions. This tool provides the user with a method to validate algorithms against current ISO standards and methods. It can also be used to validate third party algorithms by making the output data available for use in third party applications		

Features	BeamGage® Standard	Upgrade to BeamGage® Professional to include: (all features in Standard plus)
Camera Features	Camera features are governed by the capabilities of the various cameras that will interface with these software products, and second by which of these camera features are implemented in the software. This section will describe typical camera features supported in the application	
	Black Level Control (used by Ultracal and Auto-X and Auto-setup)	
	Gain Control (used by Auto-X and Auto-setup)	
	Exposure Control (used by Auto-X and Auto-setup)	
	User Programmable ROI	
	Pixel Binning	
	Pixel Sampling	
	Bits per pixel setting	
	External Trigger Input	
	Trigger Delay	
	Strobe Output	
	Strobe Delay	
	External Trigger Probe	
	Internal Trigger Probe	
Camera related features in the applications	These are features related to but not generally dependent upon the camera design	
	Gamma Correction	
	Gain Correction	
	Bad Pixel Correction	
	Lens Applied Option	
	Pixel scale settings	
	Magnification settings	
	Frame buffer settings	
	Ultracal	
	Enable Auto-X (auto exposure control)	
	Perform an Auto-Setup	
	8/10/12/14/16 bits per pixel	
	Select Format or ROI	
	Measure S/N ratio	
Trigger, Capture and Synchronization Methods	Capture methods are features related to the application while Synchronization methods relate more to the abilities of the specific camera. NOTE: Frame capture rates are determined by many factors and are not guaranteed for any specific operating configuration	
	Trigger modes	
	• CW - captures continuously, see Capture Options below	
	• Trigger-In from laser: Trigger pulses supplied to the camera	
	• Strobe-Out to laser: Strobe pulses output from the camera	
	• Video Trigger: Frame captured and displayed only when the camera sees a signal greater than a user set level	
	Capture options	
	• Capture options are redefined and are approached in a different manner than older products. The items listed below will allow for all of the previous methods but with more flexibility than ever before	
	• Results Priority: Results priority will slow the capture rate to be in sync with the computational results and display updates	
	• Frame Priority: Frame priority will slow results and display updating to insure that frames are collected and stored in the frame buffer as fast as possible (replaces block mode)	
	• Stop After: Will collect a set number of frames and then stop (replaces Single-Shot mode)	
	• Periodic: Will collect frame at a programmed periodic rate	
	• Periodic Burst: Will collect frames in a Burst at programmed periodic rates	
	• Post processing is still available but is done via a different mechanism and is limited to only data file sources	
Video Playback	Video playback, post processing and post analysis	
	User customizable playback rates	
	Video file quick pan/search controls	
	Whole video file playback looping with sub-selection looping	
	Playback Video produced by logging	
	Almost all measurements can be performed on video files	
System Requirements	PC computer running Windows 7 (64) and Windows 10 Laptop or Desktop	
	Not all cameras run in all Microsoft OS versions, see camera section for specifics	
	GHz Pentium style processor, dual core recommended	
	Minimum 2GB RAM (4GB required for L11059 camera)	Minimum 3-4GB RAM
	Accelerated Graphics Processor	
	Hard drive space suitable to hold the amount of video data you expect to store (50-100 GB recommended)	

3.3.4 Cameras for BeamGage®

The new MKS Ophir camera naming convention

The beam profiling camera model names represent the sensor size, type and a product release order.

SP_{xyz}A

X - Sensor Format:	yz	A - Sensor Type:
1. <0.5"	Product Release Index	S - Silicon I - InGaAs P - Phosphorus coating
2. 0.5"-1/1.8"		
3. 1/1.81"-0.99"		
4. 1"- 1.25"		
5. 1.25"- 1.99"		
6. ≥ 2"		

Example: SP204S

"2" represents, a small, up to 1/1.8" sensor format, "04" a release index, and the "S" means Si-based sensor, capable of measuring 300-1100nm laser beams.

Camera Compatibility

- For lasers between 190-1100nm wavelengths, BeamGage interfaces to both silicon CCD and CMOS USB cameras.
- For applications between 1440-1605nm, BeamGage supports cost effective phosphor coated CCD cameras.
- For demanding applications between 900-1700nm, BeamGage supports an InGaAs camera.
- For applications in the ultraviolet, 13-355nm, or far infrared or Terahertz range, 1.06-3000nm, BeamGage supports Spiricon's Pyrocam™, pyroelectric array cameras.

190-1100nm*



Model	SP932U	SP204S
Application	1/1.8" format, slim profile, wide dynamic range, CW & pulsed lasers, adjustable ROI	1/1.8" format, slim profile, wide dynamic range, CW & pulsed lasers, adjustable ROI
Beam sizes	34.5µm - 5.3mm	27.4µm - 5.6mm
Number of effective pixels	2048 x 1536	2472 x 2064
Imager recess	4.5±0.11mm	4.5mm ±0.11mm
PC interface	USB 3.0	USB 3.0
Page in the catalog	228	228



Model	SP402S	SP504S
Application	12.3mm x 12.3mm, 1.1" format for large beams, CW & pulsed lasers, adjustable ROI	23mm x 23mm, APS-H format for large beams, CW & pulsed lasers, adjustable ROI
Beam sizes	27.4µm - 12.3mm	45µm - 23mm
Number of effective pixels	4512 x 4512	5120 x 5120
Imager recess	4.5mm ±0.11mm	12.7mm
PC interface	USB 3.0	GigE
Page in the catalog	229	229

1440-1605nm

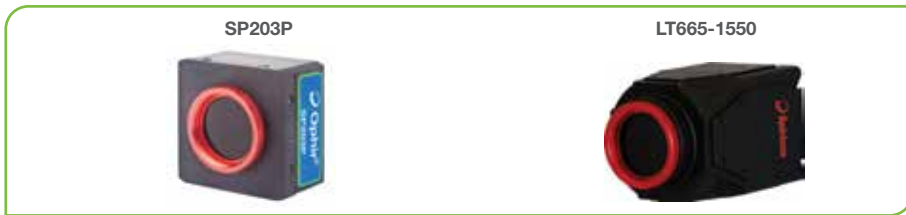

Model	SP203P	LT665-1550
Application	SWIR wavelengths, 1/1.8" format	12.5mm x 10mm, 1" format for large beams, CW & pulsed lasers, adjustable ROI
Beam sizes	600µm - 5.3mm	600µm - 9.9mm
Number of effective pixels	2048 x 1536	2752 x 2192
Imager recess	4.5mm ±0.11mm	17.5 mm
PC interface	USB 3.0	USB 3.0
Page in the catalog	231	231

900-1700nm



Model	SP1203	SP1201
Application	High resolution InGaAS performance, NIR wavelengths	InGaAS performance, NIR wavelengths
Beam sizes	150µm-7.4mm	300µm - 7.4mm
Number of effective pixels	640 x 512 (VGA)	320 x 256 (QVGA)
CCD recess	C-mount, (Optional)	C-mount, (Optional)
PC interface	GigE	GigE
Page in the catalog	232	232

13-355nm & 1.06-3000µm

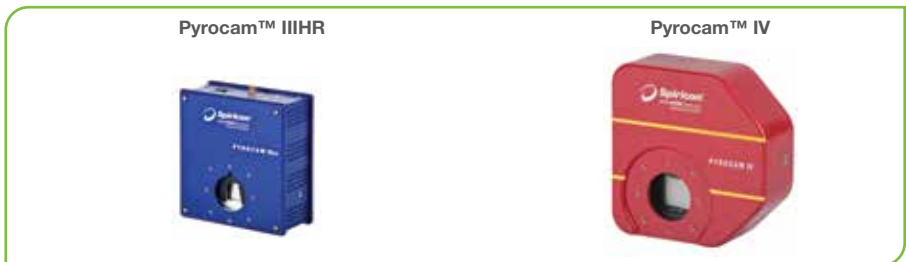

Model	Pyrocam™ IIIHR	Pyrocam™ IV
Application	UV & Far IR Only commercial array to view Terahertz	UV & Far IR Only commercial array to view Terahertz
Beam sizes	1600µm-12.7mm	1600µm-25.4mm
Number of effective pixels	160 x 160	320 x 320
CCD recess	15.15mm	19.7mm
PC interface	GigE	GigE
Page in the catalog	237	237

3.3.4.1 190-1100nm Cameras

3.3.4.1.1 USB Silicon High Resolution CMOS Camera

SP932U

Features

- Specially optimized for NIR and Nd:YAG focused lasers below 100µm via “Blooming Correction” algorithm
- 72dB true dynamic resolution, high bitrate

SP204S

Features

- Highest resolution and accuracy measurement of focused and collimated laser beams
- Frame rate, up to 37fps at full resolution
- Highest quantum efficiency



Model	SP932U	SP204S		
Format	1/1.8"	1/1.8"		
Wavelengths ⁽¹⁾	190-1100nm	190-1100nm		
Active area	7.06mm x 5.3mm	6.7mm x 5.6mm		
Beam sizes ⁽²⁾	34.5µm - 5.3mm	27.4µm - 5.6mm		
Pixel spacing	3.45µm x 3.45µm	2.74µm x 2.74µm		
Number of effective pixels	2048 x 1536	2472 x 2064		
Dynamic range	72 dB	67 dB		
Linearity with power	±1%	±1%		
Accuracy of beam width ⁽³⁾	±2%	±2%		
Frame rates in 12 bit mode ⁽⁴⁾	24 fps at full resolution	37 fps		
Exposure Time	25µs to 400ms	10µs - 400ms		
Gain control	1.46 dB to 256 dB	1.4 dB to 256 dB		
Trigger	Hardware/Software Trigger & Strobe Out	Hardware/Software Trigger & Strobe Out		
Photodiode trigger (Optional) ⁽⁵⁾	Si response: SP90408	Si response: SP90408		
Lowest measurable signal ⁽⁶⁾	0.2nW/cm ² at 633nm	0.35nW/cm ² at 530nm		
Damage threshold ⁽⁷⁾	50W/cm ² / 1J/cm ² for < 100ns pulse width	50W/cm ² / 1J/cm ² for < 100ns pulse width		
Ambient operating temperature ⁽⁸⁾	10° C - 40° C	10° C - 40° C		
Dimensions	45 mm x 45 mm x 22.5 mm	45mm x 45mm x 22.5mm		
Imager recess	4.5±0.11mm	4.5mm ±0.11mm		
Operation mode	CMOS, Global shutter	CMOS, Global Shutter		
PC interface	USB 3.1	USB 3.0		
OS supported	Windows 10 (64) and Windows 11	Windows 10 (64) and Windows 11		
Compliance	CE, UKCA, China RoHS	CE, UKCA, China RoHS		
Ordering Information				
Supported software	Item	P/N	Item	P/N
BeamGage Professional	BGP-USB3-SP932U	SP90607 ⁽⁹⁾	BGP-USB3-SP204S	SP90648 ⁽¹⁰⁾
BeamGage Standard	BGS-USB3-SP932U	SP90606 ⁽⁹⁾	BGS-USB3-SP204S	SP90647 ⁽¹⁰⁾

Notes: (1) Wavelength is typically specified down to 190nm, however the camera's natural response is from 300nm through 1100nm. To measure effectively below 300nm a UV converter is recommended, otherwise the measurement accuracy may degrade and long-term intensive irradiation at UV wavelengths may cause permanent damage to the imager.
 (2) The maximal beam size refers to “Flat-top” laser beams. For Gaussian beams, reduce maximum beam size by 1/3.
 (3) For SP204S camera, at NIR wavelengths above 900 nm and beam width below 100 µm, the accuracy would be lower.
 (4) Dependent on PC processor and graphics card performance.
 (5) For more information please see “Optical Camera Trigger” catalog page.
 (6) Camera set to full resolution at maximum frame, 400ms exposure time and without any ND filter.
 (7) This is the damage threshold of the filter glass. Assuming all filters are mounted with ND1 (red housing) filter in the front. Distortion of the beam may occur with average power densities of 5W/cm² for beam size 5mm, 10W/cm² for 2mm beam, and >30W/cm² for 1mm beam.
 (8) The storage Temp is -30°C to 70°C and Operation Humidity is 5% to 90% (non-condensing).
 (9) Comes with USB 3.0 cable, Trigger cable and 3 ND filters.
 (10) Comes with USB 3.0 cables 0.5 & 3m, Trigger cable and 3 ND filters.

SP932U/SP204S

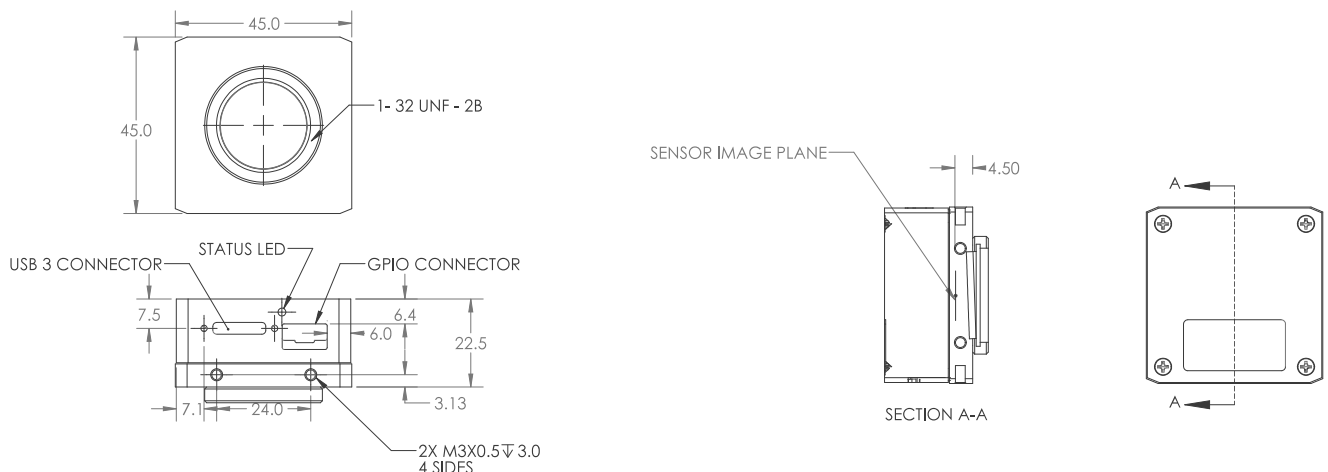

3.3.4.1.2 Large Format USB & GigE Cameras

SP402S

Features

- 1.1" imager format
- High resolution
- CMOS, Global Shutter, Back Illuminated
- 67dB true dynamic resolution

SP504S

Features

- 23mm x 23mm imager format
- Highest resolution
- CMOS, Global shutter
- 44.6 dB true dynamic resolution



Model	SP402S	SP504S
Format	1.1"	APS-H
Wavelengths ⁽¹⁾	190 - 1100nm	340 - 1100nm
Active area	12.3mm x 12.3mm	23mm x 23mm
Beam sizes ⁽²⁾	27.4µm - 12.3mm	45µm - 23mm
Pixel spacing	2.74µm x 2.74µm	4.5µm x 4.5µm
Number of effective pixels	4512 x 4512	5120 x 5120
Dynamic range	67 dB	44.6 dB
Linearity with power	±1%	±1%
Accuracy of beam width	±2%	±2%
Frame rates ⁽³⁾	11 fps (12 bit mode)	4.5 fps (10 bit mode) ⁽⁴⁾
Exposure Time	10µs - 400ms	10µs - 400 ms
Gain control	1.4 dB to 256 dB	N/A
Trigger	Hardware/Software trigger & strobe out	Hardware/software & strobe out
Photodiode trigger (Optional) ⁽⁵⁾	Si response: SP90408	Si response: SP90408
Lowest measurable signal ⁽⁶⁾	0.35nW/cm ² at 530nm	0.25nW/cm ² at 633nm
Damage threshold ⁽⁷⁾	50W/cm ² / 1J/cm ² with all filters installed for < 100ns pulse width	50W/cm ² / 1J/cm ² with all filters installed for < 100ns pulse width
Ambient operating temperature	10° C - 40° C	10° C - 40° C
Dimensions	45mm x 45mm x 22.5mm	68mm x 68mm x 62.6mm
Imager recess	4.5mm ±0.11mm	12.7mm
Operation mode	CMOS, Global Shutter	CMOS, Global shutter
PC interface	USB 3.0	GigE (POE)
OS supported	Windows 10 (64) and Windows 11	Windows 10 (64) and Windows 11
Compliance	CE, UKCA, China RoHS	CE, UKCA, China RoHS

Ordering Information

Supported software	Item	P/N	Item	P/N
BeamGage Professional	BGP-USB3-SP402S	SP90643 ⁽⁸⁾	BGP-G-SP504S	SP90618 ⁽⁹⁾
BeamGage Standard	BGS-USB3-SP402S	SP90642 ⁽⁸⁾	N/A	N/A

Accessories

LBS-400 to SM2 Adapter	SP98000
LBS-100 to SM2 Adapter	SP98001

- Notes:
- (1) Wavelength is typically specified down to 190nm, however the camera's natural response is from 300nm through 1100nm. To measure effectively below 300nm a UV converter is recommended, otherwise the measurement accuracy may degrade and long-term intensive irradiation at UV wavelengths may cause permanent damage to the imager.
 - (2) The maximal beam size refers to "Flat-top" laser beams. For Gaussian beams, reduce maximum beam size by 1/3.
 - (3) Dependent on PC processor and graphics card performance.
 - (4) Value is for 2x2 binning. When in full frame format, the maximum frame rate is 2 fps.
 - (5) For more information please see "Optical Camera Trigger" catalog page.
 - (6) Camera set to full resolution at maximum frame rate, 400ms exposure time and without any ND filter.
 - (7) This is the damage threshold of the filter glass. Assuming all filters mounted with ND1 (red housing) filter in the front. Distortion of the beam may occur with average power densities of 5W/cm² for beam size 5mm, 10W/cm² for 2mm beam and >30W/cm² for 1mm beam.
 - (8) Comes with USB 3.0 cable, Power with Trigger cable and 3 ND filters.
 - (9) Comes with Cat6 cable, Trigger cable, SM2 adapter, and 3 ND filters: ND1, ND2, ND3 (ND3 mounted in camera)

SP402S

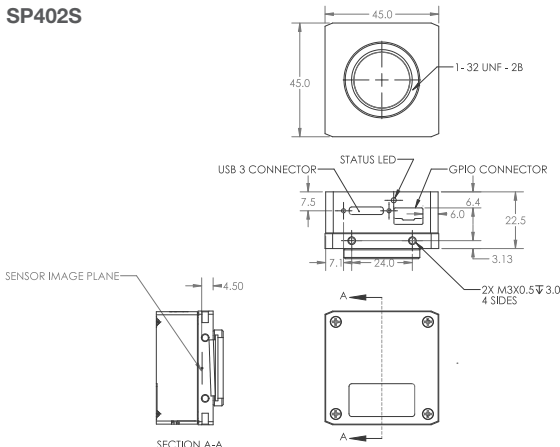

SP504S

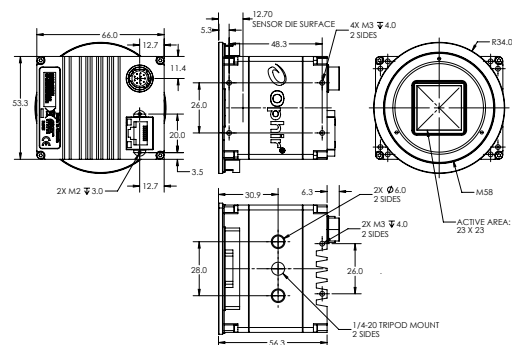

3.3.4.2 1440-1605nm Cameras

Phosphor Coating Technology

The up-conversion from NIR to visible light in the 1550 series cameras is nonlinear. The anti-Stokes phosphor coating produces visible photons at a rate roughly the square of the input signal. This is shown dramatically where the camera total output increases dramatically faster than a linear output shown in the bottom line. The CCD camera saturation in the center of a beam, the up-converted visible signal drops as the square of the input signal. Thus the lower signal wings of a beam are suppressed, resulting in the appearance and measurement of a beam width much smaller than actual.

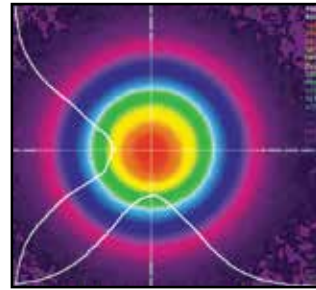

1550nm Fiber Output

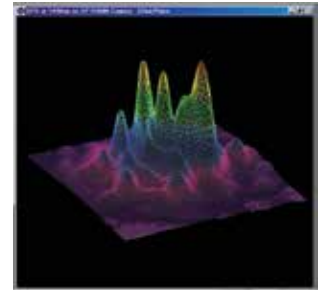

1610nm OPO Output

This illustration is a comparison of the cross-section of a beam with and without correction. As seen, the real width of the beam is much greater than would be observed without correction.

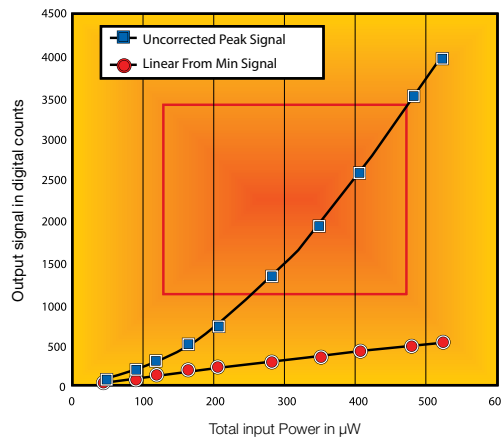

Non-Linearity of SP-1550M Camera at 1550nm

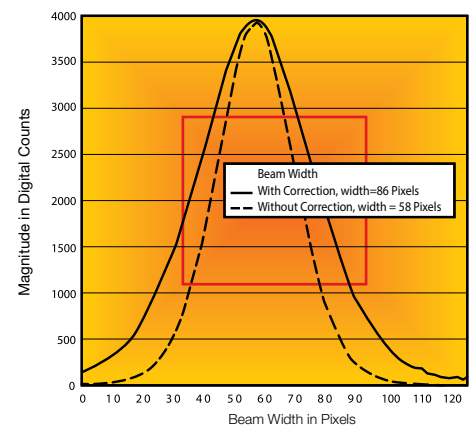

SP-1550M Camera: Comparison of Beam Shape with and without Correction Factor

Wavelength Response

The anti-Stokes up-conversion efficiency is very wavelength dependent. This graph shows the typical spectral response curve of a new, high response coating. As seen, we have calibrated the response from 1527nm to 1605nm. We have extrapolated the shorter wavelength region by comparing our measured response to data published over the entire range.

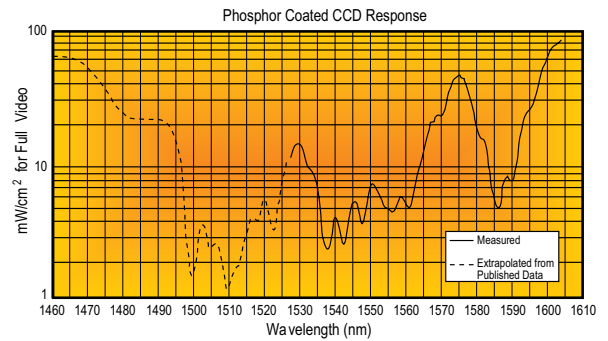

Signal required versus wavelength to achieve camera full signal illumination by anti-Stokes up conversion material.

Phosphor Coated Cameras with Spiricon's BeamGage software

Spiricon's engineers have carefully measured the non-linearity of the signal generated by the Phosphor Coated series cameras. The software in the BeamGage incorporates an algorithm to correct for the non-linearity. This illustration shows the linearity obtained, showing in the top line that the low level signals drop linearly, rather than at the square of the input, seen in the lower line.

The two photos show the uncorrected and corrected camera beam shape in 3D. See the BeamGage section for additional information on the beam analyzer.

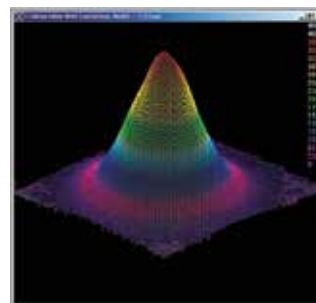

Beam profile of a fiber beam with non-linearity correction.

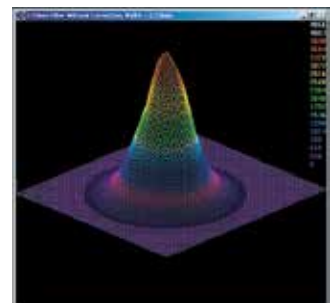

Beam profile of a fiber beam without non-linearity correction.

3.3.4.2.1 Phosphor Coated CMOS And CCD Cameras For NIR Response

Features

- 1440-1605nm Wavelengths
- NIR Telecom mode field analysis
- NIR Laser beam analysis

Available Models

- USB models: SP203P
- Large Format: LT665-1550



Model	SP203P	LT665-1550
Application	SWIR wavelengths, 1/1.8" format	NIR wavelengths, 1" format
Wavelengths	1440 - 1605nm	1440 - 1605nm
Active area	7.06mm x 5.3mm	12.5mm x 10mm
Beam sizes ⁽¹⁾	600µm - 5.3mm	600µm - 9.9mm
Pixel spacing ⁽²⁾	3.45µm x 3.45µm	4.54µm x 4.54µm
Number of effective pixels	2048 x 1536	2752 x 2192
Dynamic range ⁽³⁾	~32 dB	~30 dB
Linearity with power	±5%	±5%
Accuracy of beam width	±5%	±5%
Frame rates in 12 bit mode ⁽⁴⁾	24 fps at full resolution	27 fps at full resolution
Exposure	25µs - 400ms	31µs to multiple frames
Gain control	1.4 dB to 256 dB	0.8 dB to 56 dB
Trigger	Supports both trigger and strobe out	Supports both trigger and strobe out
Photodiode trigger (Optional) ⁽⁵⁾	InGaAs response: SP90409	InGaAs response: SP90409
Saturation intensity	200W/cm ² at 1550nm For exposure time of 1 ms	
Lowest measurable signal	0.5µW/cm ² at 1550nm For exposure time of 400 ms	
Damage threshold	50W/cm ² / 1J/cm ² with all filters installed for < 100ns pulse width ⁽⁶⁾	
Ambient operating temperature	10°C to 40°C	0 - 50° C. Recommended to connect to heat sink
Dimensions	45mm x 45mm x 22.5mm	43mm x 43mm x 65mm
Imager recess	4.5mm ±0.11mm	17.5mm
Operation mode	CMOS, Global Shutter	Quad Tap interline transfer CCD
PC interface	USB 3.0	USB 3.0
OS supported	Windows 10 (64) and Windows 11	
Compliance	CE, UKCA, China RoHS	

Ordering Information

Supported software	Item	P/N	Item	P/N
BeamGage Professional ⁽⁷⁾	BGP-USB3-SP203P	SP90637	BGP-USB3-LT665-1550	SP90385 ⁽⁸⁾
BeamGage Standard ⁽⁷⁾	BGS-USB3-SP203P	SP90636	BGS-USB3-LT665-1550	SP90384 ⁽⁸⁾

- Notes:
- (1) The maximal beam size refers to "Flat-top" laser beams. For Gaussian beams, reduce maximum beam size by 1/3. Below beam sizes of 1.5 mm, the measurement error increases due to the broadening created by the thickness of the phosphor layer.
 - (2) Despite the small pixel size, the spatial resolution will not exceed 50µm due to diffusion of the light by the phosphor coating.
 - (3) Signal to noise ratio is degraded due to the gamma of the phosphor's response. Averaging or summing of up to 256 frames improves dynamic range by up to 16x = +24 dB.
 - (4) In normal (non-shuttered) camera operation, the frame rate is the fastest rate at which the laser may pulse and the camera can still separate one pulse from the next. With electronic shutter operation, higher rate laser pulses can be split out by matching the laser repetition to the shutter speed.
 - (5) For more information please see "Optical Camera Trigger" catalog page.
 - (6) This is the damage threshold of the filter glass of the filters. Assuming all filters mounted with ND1 (red housing) filter in the front. Distortion of the beam may occur with average power densities of 5W/cm² for beam size 5mm, 10W/cm² for 2mm beam and >30W/cm² for 1mm beam.
 - (7) Comes with USB 3.0 cable, Trigger cable and 3 ND filters.

SP203P

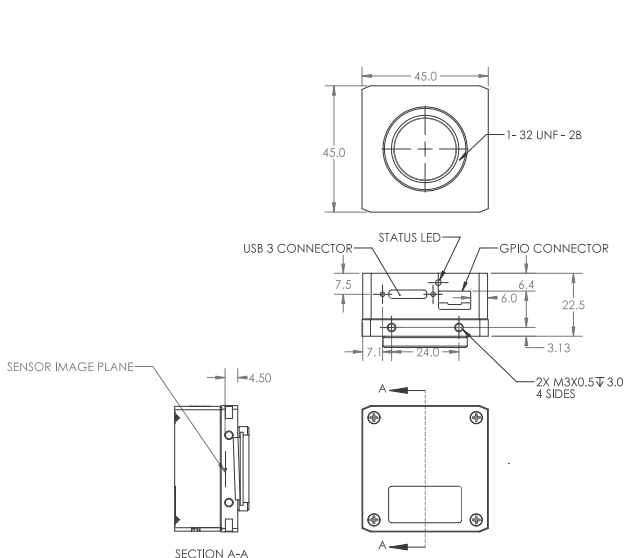

LT665 - 1550

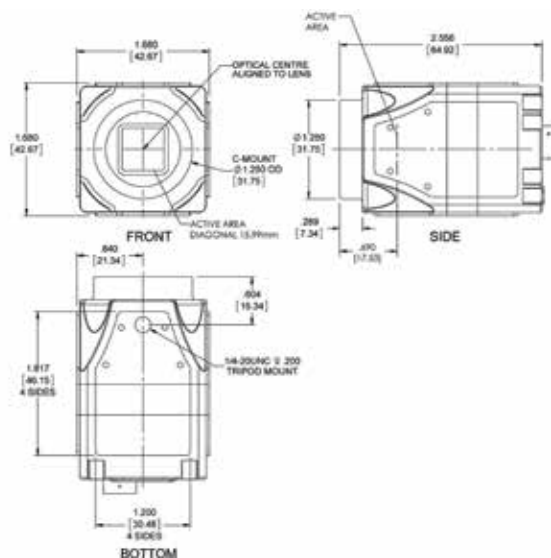

3.3.4.3 900-1700nm Camera

3.3.4.3.1 GigE InGaAs NIR Camera

SP1203 high resolution, SP1201 low resolution

Features

- NIR performance
- Resolution:
 - VGA: SP1203
 - QVGA: SP1201
- Exclusive Ultracal for ISO conforming accuracy
- Available with BeamGage software

SP1203/SP1201



Model	SP1203	SP1201		
Application	NIR wavelengths, high resolution, ROI and binning	NIR wavelengths, ROI and binning		
Wavelengths	900-1700nm	900-1700nm		
Active area	9.6 x 7.6mm	9.6 x 7.6mm		
Pixel spacing	15µm square	30µm square		
Beam sizes ⁽¹⁾	150µm-7.4mm	300µm-7.4mm		
Number of effective pixels	640 x 512 (VGA)	320 x 256 (QVGA)		
CCD recess	C-mount, (Optional)	C-mount, (Optional)		
Dynamic range	68dB	59dB		
Saturation Intensity ⁽²⁾	12.6 µW/cm ² @ 1064nm 8.9 µW/cm ² @ 1550nm	0.4 µW/cm ² @ 1064nm 0.2 µW/cm ² @ 1550nm		
Frame rate ⁽³⁾	60 Hz	60 Hz		
Non-uniformity correction (NUC)	Automatic NUC table selection	Automatic NUC table selection		
Snap-shot mode	Via external TTL trigger, cable provided	Via external TTL trigger, cable provided		
Compatible light sources	CW, Pulsed	CW, Pulsed		
Trigger	Supports both Trigger and strobe out	Supports both Trigger and strobe out		
Photodiode trigger (Optional) ⁽⁴⁾	InGaAs response: SP90409	InGaAs response: SP90409		
Exposure control	10µs-50ms	150µs-10ms		
Imager Cooling	Integrated Thermo-Electric Sensor Cooling (TEC)	Integrated Thermo-Electric Sensor Cooling (TEC)		
Ambient operating temperature	10°-40° C	10°-40° C		
Dimensions	55mm x 55mm x 78mm	55mm x 55mm x 78mm		
Weight	370 g (0.8 lbs)	370 g (0.8 lbs)		
PC interface	GigE (POE)	GigE (POE)		
Compliance	CE, UKCA, China RoHS			
Ordering Information				
Supported software	Item	P/N	Item	P/N
BeamGage Professional	BGP-GigE-SP1203	SP90524	BGP-GigE-SP1201	SP90523
	SP1203 Kit ⁽⁵⁾	SP90536	SP1201 Kit ⁽⁵⁾	SP90535
BeamGage Professional (for USA only)	BGP-GigE-SP1203	SP90548	BGP-GigE-SP1201	SP90547

Notes: (1) The maximal beam size refers to "Flat-top" laser beams. For Gaussian beams, reduce maximum beam size by 1/3.
 (2) Camera set to full resolution and 10 ms exposure time, CW source.
 (3) Highly dependent on PC processor and graphics adapter performance.
 (4) For more information please see "Optical Camera Trigger" catalog page.
 (5) Contains BeamGage Professional License, USB 3.0 cable to Gigabit Ethernet Adaptor, CAT6 Ethernet Cable, Power with Trigger cable and 3 ND filters.

SP1203/SP1201

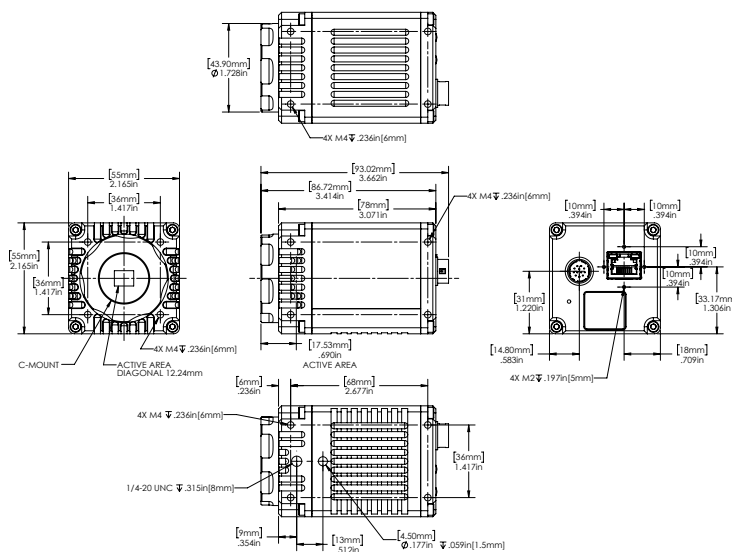

3.3.4.4 13-355nm and 1.06-3000µm Cameras

Pyroelectric Technology

Spiricon has been the world leader in the manufacture of pyroelectric solid-state detector arrays and cameras. For over 25 years the Pyrocam™ has been the overwhelming camera of choice for Laser Beam Diagnostics of IR and UV lasers and high temperature thermal imaging. Precision, stability, reliability, and versatility have become its proud heritage.

The Pyrocam IIIHR offers a 1/2X1/2 inch detector array with easy Windows® camera setup and quantitative image display through the BeamGage software, 16 bit digitizer, versatile Gigabit Ethernet PC interface, and an integral chopper for CW beams and thermal imaging.

The Pyrocam IV offers a 1X1 inch detector array with easy Windows® camera setup and quantitative image display through the BeamGage software, 16 bit digitizer, with a high-speed Gigabit Ethernet PC interface, and an integral chopper for CW beams and thermal imaging.

See Your Beam As Never Before

Both Pyrocam™ cameras create clear and illuminating images of your laser beam profile. Displayed in 2D or 3D views, you can immediately recognize beam characteristics that affect laser performance and operation. This instantly alerts you to detrimental laser variations. Instantaneous feedback enables timely correction and real-time tuning of laser parameters. For example, when an industrial shop foreman saw the CO₂ laser beam profile in Figure 1 he knew immediately why that laser was not processing materials the same as the other shop lasers, that had similar profiles shown in Figure 2.

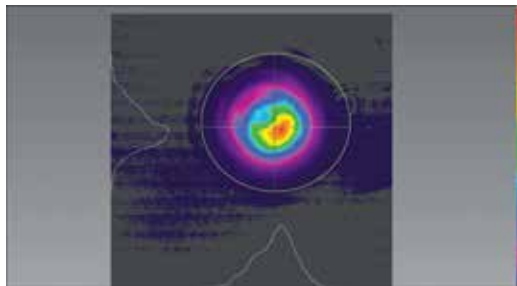

2D CO₂ laser beam

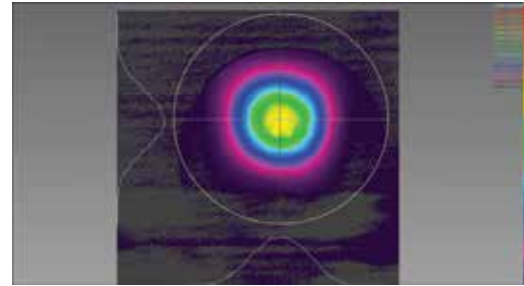

2D CO₂ laser beam

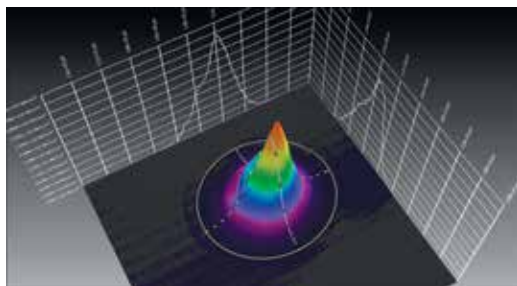

3D CO₂ laser beam

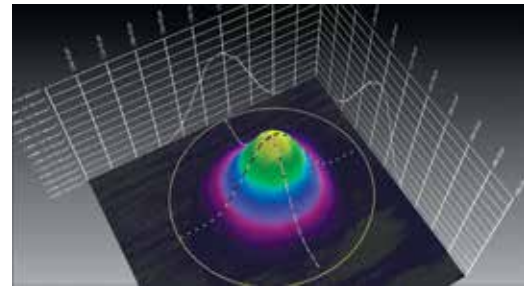

3D CO₂ laser beam

Figure 1 - Distorted spot, not good for material processing

Figure 2 - Good spot for material processing

Pulsed and CW Lasers

The Pyrocams measure the beam profile of both pulsed and CW lasers. Since the pyroelectric crystal is an integrating sensor, pulses from femtosecond to 12.8ms can be measured. The pyroelectric crystal only measures changes in intensity, and so is relatively immune to ambient temperature changes. Because CW laser beams must be chopped to create a changing signal, the Pyrocam™ contains an integral chopper.

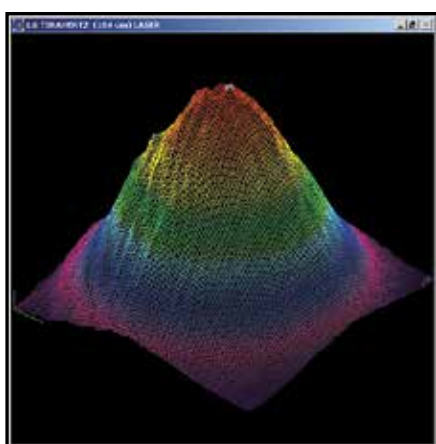

Pyrocam III imaging THz laser beam at 0.2THz (1.55mm) 3mW input power; 19 frames summed

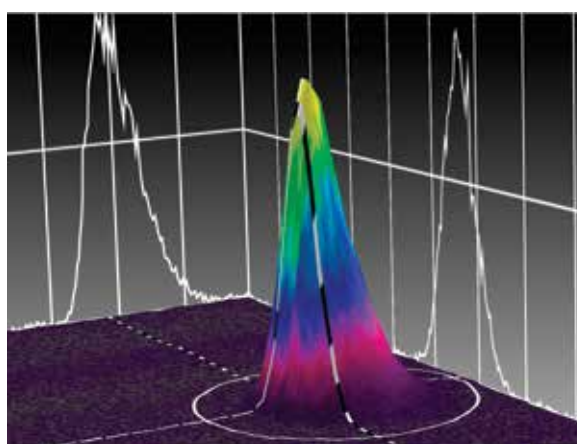

Pyrocam IV imaging THz laser beam 0.5 THz (5mm) 5mW input power; single frame

Measuring Terahertz Beam Profiles

Spiricon's Pyrocam pyroelectric cameras are an excellent tool for measuring THz lasers and sources. The coating of the crystal absorbs all wavelengths including 1μm to over 3000μm (0.1THz to 300THz). For THz sources the sensitivity of the Pyrocam is relatively low, at about 1.5mW/cm² at full output. With a S/N of 1000, beams of 30mW/cm² are easily visible.

In addition, with Spiricon's patented Ultracal baseline setting, multiple frames can be summed to "pull" a signal out of the noise. Summing 256 frames enables viewing of beams as low as 0.5-1.0mW/cm².

Broad Wavelength Response

The Pyrocam detector array has a very broadband coating which enables operation at essentially all IR and UV laser wavelengths. The curve ends at 100nm in the UV, but X-ray operation has been observed. Likewise the curve ends at 100μm in the far IR, but the camera has been used at >3000μm.

Thus you can use the Pyrocam in the near IR for Nd:YAG lasers at 1.06μm, and for infrared fiber optics at 1.3μm and 1.55μm. Use the Pyrocam for HF/DF lasers near 4μm and for Optical Parametric Oscillators from 1 μm to 10μm. It measures Free Electron Lasers between 193μm and 3000μm.

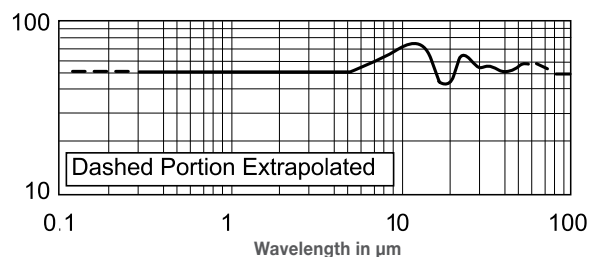

Spectral response of Pyrocam III detector array without window.

The Pyrocam™ is extremely useful in the UV from 13nm to 355nm for Excimer lasers and for tripled or quadrupled Nd:YAG lasers. The detector is stable under UV illumination, without the deterioration experienced by CCD cameras. (The pyroelectric detector operates in the visible spectrum, and can see the alignment HeNe used with CO₂ lasers. However, spurious response from the underlying silicon multiplexer creates undesirable performance, and the camera is not recommended for quantitative visible measurements).

BeamGage Image Analysis Software

Both Pyrocams come bundled with BeamGage, the state-of-the-art beam profiling system that performs rigorous data acquisition and analysis of laser beam parameters, such as beam size, shape, uniformity, divergence, mode content, and expected power distribution. Once the Pyrocam is connected to the PC and BeamGage is running, the software automatically detects the camera presence and is immediately ready to start taking images and displaying them on the monitor.

BeamGage is the industry's first beam profiling software to be newly designed, from scratch, using the most advanced tools and technologies. BeamGage is based on UltraCal™, Spiricon's patented baseline correction algorithm that helped establish the ISO 11146-3 standard for beam measurement accuracy.

BeamGage provides high accuracy results, guaranteeing the data baseline (zero-point reference) is accurate to 1/8th of a digital count on a pixel-by-pixel basis.

BeamGage permits the user to employ custom calculations for best fit to an individual application. These user-defined computations are treated like the standard calculations. They can be displayed on the monitor, logged with results, and included in hard-copy reports.

The system also allows the user to configure the displayed calculations, set-up the screen layout, and password-protect the configuration. This permits secure product testing, ensures security in production environments where plant floor personnel interface with the system, and assures the validity of the data for Statistical Process Control (SPC).

Hybrid Integrated Circuit Sensor

The Pyrocam consists of a LiTaO₃ pyroelectric crystal mounted with indium bumps to a solid-state readout multiplexer. This sensor, developed as the Company's core technology for the Pyrocam I, has proven to be the most rugged, stable, and precise IR detector array available. Light impinging on the pyroelectric crystal is absorbed and converted to heat, which creates charge on the surface. The multiplexer then reads out this charge. For use with short laser pulses, the firmware in the camera creates a very short electronic shutter to accurately capture the thermally generated signal.

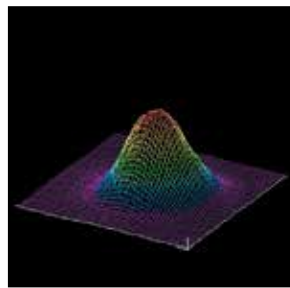

Er:YAG laser at 2.9µm.

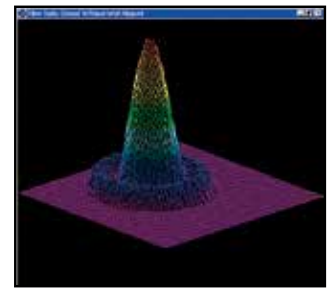

Output of infrared fiber optic.

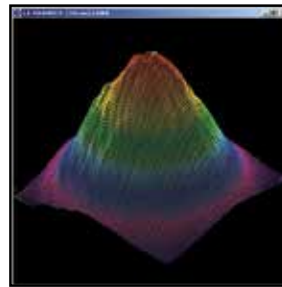

THz laser beam at 1.6THz (184µm).

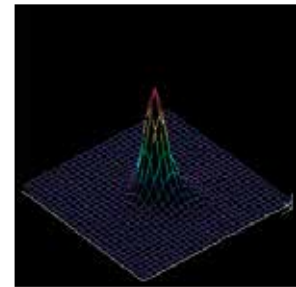

Free Electron laser at 100µm.

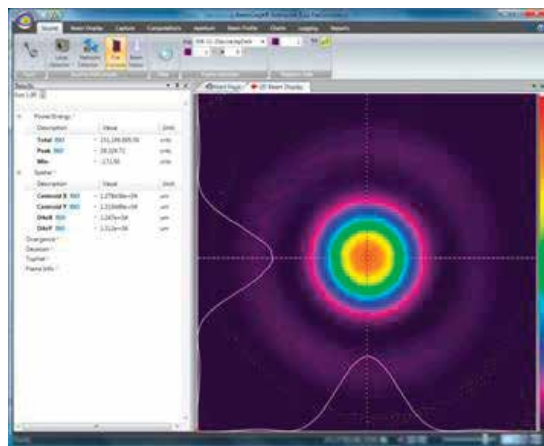

BeamGage recognizes the Pyrocam IIIHR & IV and allows you to quickly start analyzing your laser beam

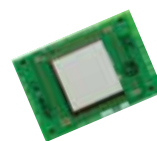

Pyrocam IIIHR 12.8X12.8mm array

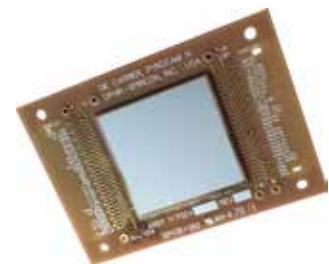

Pyrocam IV 25mm X 25mm array

State-Of-The-Art Electronics

The camera features a high resolution A/D converter which digitizes deep into the camera noise. This enables reliable measurement and analysis of both large signals and low level signals in the wings of the laser beam. High resolution digitizing

also enables accurate signal summing and averaging to pull weak signals out of noise. This is especially useful with fiber optics at 1.3 μ m and 1.55 μ m, and in thermal imaging.

Applications Of The Pyrocam™ IIIHR

The Pyrocam is an ideal camera for use in scientific laboratory investigation of laser beams. This includes physics, chemistry, and electronic system designs. As an example, the photos on the right side show a research CO₂ laser and a research Nd:YAG laser, both with cavity misalignment.

The camera is also useful in product engineering of CO₂ and other infrared lasers. The Pyrocam is an integral part of the assembly lines of many CO₂ laser manufacturers. Integrators of systems are using the Pyrocam sensor to make sure that optical systems are aligned and operating properly.

There are many medical applications of the Pyrocam, such as the analysis of excimer lasers used for eye surgery. In many cases these lasers need alignment to ensure that the eye surgery is performed as expected. Other medical IR lasers perform dermatology, for which the uniformity of the beam profile must be assured.

Fiber optic communications, at 1.3 μ m and 1.55 μ m make significant use of the Pyrocam for analyzing the beams being emitted, as well as analyzing properties of the beams before launching them into fibers. The greater stability of the Pyrocam make it a good choice over other cameras operating at telecommunication wavelengths.

The Pyrocam is becoming an essential tool in the maintenance of industrial infrared lasers, especially CO₂. The Pyrocam replaces non-electronic mode burns and acrylic blocks by providing higher definition electronic recording of

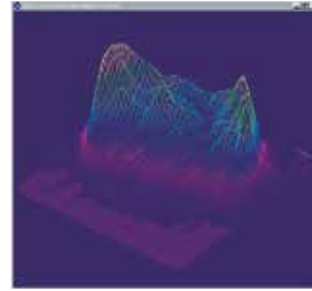

CO₂ laser with cavity misalignment.

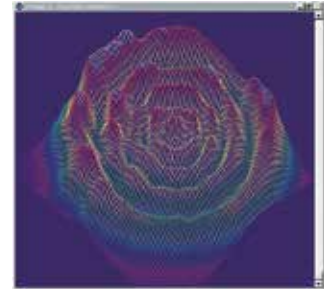

Nd:YAG laser with cavity misalignment.

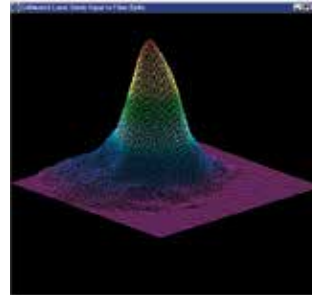

CO₂ laser with cavity misalignment.

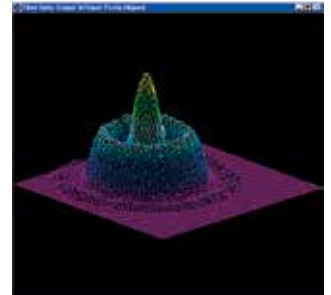

Nd:YAG laser with cavity misalignment.

data, and analysis of short term fluctuations. The Pyrocam is superior to other electronic methods of measuring CO₂ lasers because the entire beam can be measured in a single pulse, and additional measurements made in real-time. This ensures that the beam did not change during the measurement.

Detector Damage Threshold

The Pyrocam sensor is capable of operation with intensities about 100 times greater than CCD cameras. This makes the camera ideal for use with high power lasers, as less attenuation is required. Nevertheless, pulsed lasers with fluence too high can evaporate the absorbing front electrode.

As shown the damage threshold increases with pulse width. With nanosecond and longer pulses, detector saturation occurs before damage.

With shorter pulses it helps to increase the camera amplifier gain so that electronic saturation occurs before damage.

The sensor can be damaged by excessive CW power, which causes crystal cracking. Very few Pyrocam detectors have been damaged by CW power, but some have been ablated by high peak pulse energy.

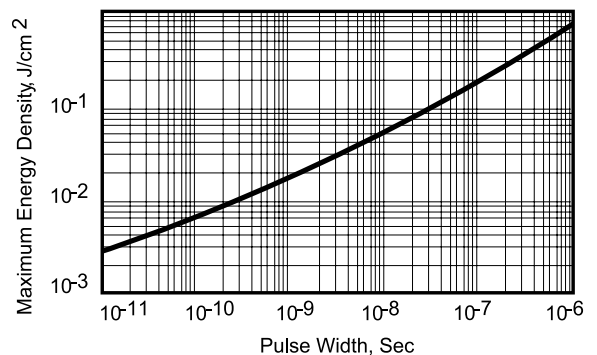

Pulsed damage threshold of pyroelectric detector coating.

3.3.4.4.1 Pyroelectric Array Cameras

Pyrocam™ IIIHR & Pyrocam™ Series

Features

- Spectral ranges available from 13 to 355nm and 1.06 to >3000µm
- Image CO2 lasers, telecom NIR lasers, THz sources and other infrared sources out to Far IR
- Solid state array camera with 1000:1 linear dynamic range for accurate profiling
- Integrated chopper for CW beams and thermal imaging
- Interchangeable windows available for a variety of applications
- Includes BeamGage® Laser Beam Analysis Software for quantitative analysis and image display



Model	Pyrocam IIIHR		Pyrocam IV					
Application	UV and IR	MIR ⁽¹⁾	UV and IR	MIR ⁽¹⁾				
Wavelengths	13 - 355nm	3 - 5µm	13 - 355nm	3 - 5µm				
	1.06 - 3000µm		1.06 - 3000µm					
Interchangeable windows	See selection in Ordering section		See selection in Ordering section					
Detector array details								
Active area	12.8mm x 12.8mm		25.6mm x 25.6mm					
Beam sizes ⁽²⁾	1600µm - 12.7mm		1600µm - 25.4mm					
Pixel spacing	80µm x 80µm		80µm x 80µm					
Number of effective pixels	160 x 160		320 x 320					
Pixel size	75µm x 75µm		75µm x 75µm					
Chopped CW operation								
Chopping frequencies	25Hz, 50Hz		25Hz, 50Hz					
Lowest measurable signal	64nW/pixel or 1.0 mW/cm ² (25Hz) 96nW/pixel or 1.5 mW/cm ² (50Hz)		64nW/pixel (25Hz) or 1.0mW/cm ² (25Hz) 96nW/pixel (50Hz) or 1.5mW/cm ² (50Hz)					
Noise equivalent power (NEP)	13nW/Hz ^{1/2} /pixel (1Hz)		13nW/Hz ^{1/2} /pixel (1Hz)					
Saturation intensity (25Hz, 50Hz)	3.0W/cm ² , 4.5W/cm ²		3.0W/cm ² , 4.5W/cm ²					
Damage threshold power								
Over entire array	2W		2W					
Peak Power Density	8W/cm ² (Chopped mode) 4W/cm ² (CW in pulsed mode)		8W/cm ² (Chopped mode) 4W/cm ² (CW in pulsed mode)					
Pulsed operation								
Laser pulse rate	Single-shot to 1000Hz		Single-shot to 1000Hz					
Pulse width	1fs - 12.8ms		1fs - 12.8ms					
Lowest measurable signal	0.5nJ/pixel		0.5nJ/pixel					
	8µJ/cm ²		8µJ/cm ²					
Saturation energy	15mJ/cm ²		15mJ/cm ²					
Damage threshold	20mJ/cm ² (1ns pulse) 600mJ/cm ² (1µs pulse)		20mJ/cm ² (1ns pulse) 600mJ/cm ² (1µs pulse)					
Trigger input								
High logic level	3.5 - 6.0V DC		3.5 - 6.0V DC					
Low logic level	0 - 0.8V DC		0 - 0.8V DC					
Pulse width	4µs min		4µs min					
Trigger	Supports both trigger and strobe out		Supports both trigger and strobe out					
Photodiode trigger (Optional) ⁽³⁾	InGaAs response: SP90409		InGaAs response: SP90409					
Operating & conditions								
Power	12VDC		12VDC					
Line frequency	60/50Hz External Supply		60/50Hz External Supply					
Power consumption	12W		12W					
Operating temperature	5°C to 50°C		5°C to 50°C					
Physical								
Dimensions	140mm H X 130mm W X 60mm D		147.3mm H X 147.1mm W X 55.2mm D					
Detector Position	Centered in width 35.6mm from bottom 15.15 ± .75mm behind front cover (without included C-mount attached) Tilt <2°		53.8mm from bottom left 36.8mm from bottom 19.7 ± .75mm behind front cover Tilt <2°					
Weight	0.85Kg (1.83lbs)		1.2kg (2.65lbs)					
PC interface	Gigabit Ethernet (IEEE 802.3ab), GigE Vision compliant		Gigabit Ethernet (IEEE 802.3ab), GigE Vision compliant					
OS supported	Windows 7 (64) and Windows 10		Windows 7 (64) and Windows 10					
Compliance	CE, UKCA, China RoHS		CE, UKCA, China RoHS					
Array quality	<75 bad pixels, all correctable No uncorrectable clusters		<300 bad pixels, all correctable No uncorrectable clusters					
Ordering information								
Supported software	Item	P/N	Item	P/N	Item	P/N	Item	P/N
BeamGage Professional	PY-III-HR-C-A-PRO	SP90405 ⁽⁴⁾	PY-III-HR-C-MIR-PRO	SP90415 ⁽⁴⁾	PY-IV-C-A-PRO	SP90404 ⁽⁵⁾	PY-IV-C-MIR-PRO	SP90414 ⁽⁵⁾

Notes: (1) The MIR (Mid-IR) versions on the Pyrocam IIIHR and IV are designed specifically for Mid-IR lasers in the spectral range 3 to 5µm. The MIR versions feature specifically designed sensors that maximize the optical signal for high fidelity spatial profile measurements of laser beam in the 3 to 5µm spectral range. (2) The maximal beam size refers to "Flat-top" laser beams. For Gaussian beams, reduce maximum beam size by 1/3. (3) For more information please see "Optical Camera Trigger" catalog page. (4) Comes with USB 3.0 cable to Gigabit Ethernet Adaptor, CAT6 Ethernet Cable, Trigger cable SMA to BNC, power supply with locking connector, and adapter Kit for C-Mount Lens. (5) Comes with USB 3.0 cable to Gigabit Ethernet Adaptor, CAT6 Ethernet Cable, Trigger cable SMA to BNC and power supply with locking connector.

* For drawings and accessories ordering information please see page 238

Pyrocam IIIHR

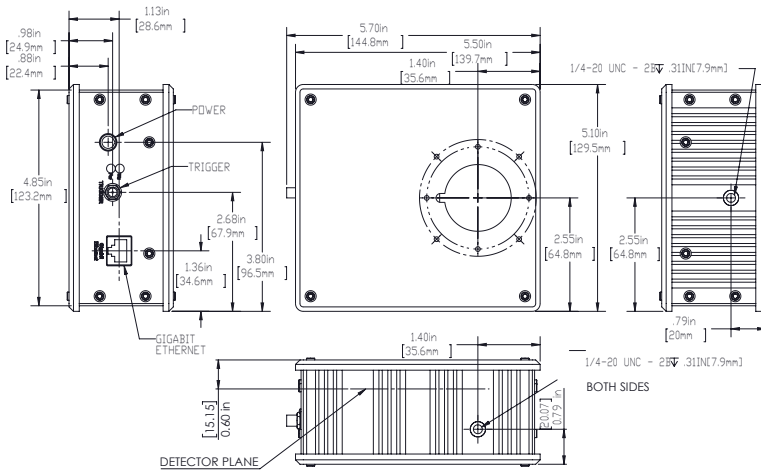

Pyrocam IV

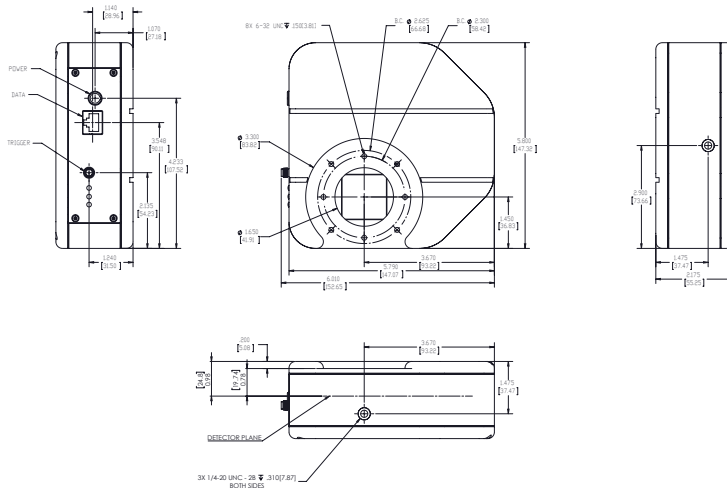

Accessories Ordering Information

Item	Description	P/N
Optional windows for Pyrocam™ IIIHR		
PY-III-HR-W-BK7-1.064	Pyrocam III-HR window assembly, BK7, A/R coated for 1.064µm	SP90365
PY-III-HR-W-SI-1.05-2.5	Pyrocam III-HR window assembly, Si, A/R coated for 1.05 to 2.5µm	SP90366
PY-III-HR-W-SI-2.5-4	Pyrocam III-HR window assembly, Si, A/R coated for 2.5 to 4µm	SP90367
PY-III-HR-W-GE-3-5.5	Pyrocam III-HR window assembly, Ge, A/R coated for 3 to 5.5µm	SP90368
PY-III-HR-W-GE-10.6	Pyrocam III-HR window assembly, Ge, A/R coated for 10.6µm	SP90369
PY-III-HR-W-GE-8-12	Pyrocam III-HR window assembly, Ge, A/R coated for 8 to 12µm	SP90370
PY-III-HR-W-ZNSE-10.6	Pyrocam III-HR window assembly, ZnSe, A/R coated for 10.6µm	SP90371
PY-III-HR-W-ZNSE-10.2µm & 10.6µm	Pyrocam III-HR window assembly, ZnSe, A/R coated for 10.2µm & 10.6µm	SP90412
PY-III-HR-W-ZNSE-2-5	Pyrocam III-HR window assembly, ZnSe, A/R coated for 2 to 5µm	SP90372
PY-III-HR-W-BaF2-Uncoated	Pyrocam III-HR window assembly, BaF2 uncoated for 193 to 10µm	SP90373
PY-III-HR-W-POLY-THZ	Pyrocam III-HR window assembly, LDPE, uncoated for Terahertz wavelengths	SP90374
Optional windows for Pyrocam™ IV		
PY-IV-W-BK7-1.064	Pyrocam IV window assembly, BK7, A/R coated for 1.064µm	SP90301
PY-IV-W-SI-1.05-2.5	Pyrocam IV window assembly, Si, A/R coated for 1.05 to 2.5µm	SP90302
PY-IV-W-SI-2.5-4	Pyrocam IV window assembly, Si, A/R coated for 2.5 to 4µm	SP90303
PY-IV-W-GE-3-5.5	Pyrocam IV window assembly, Ge, A/R coated for 3 to 5.5µm	SP90304
PY-IV-W-GE-10.6	Pyrocam IV window assembly, Ge, A/R coated for 10.6µm	SP90305
PY-IV-W-GE-8-12	Pyrocam IV window assembly, Ge, A/R coated for 8 to 12µm	SP90306
PY-IV-W-ZNSE-10.6	Pyrocam IV window assembly, ZnSe, A/R coated for 10.6µm	SP90307
PY-IV-W-ZNSE-2-5	Pyrocam IV window assembly, ZnSe, A/R coated for 2 to 5µm	SP90308
PY-IV-W-ZNSE-Uncoated	Pyrocam IV window assembly, ZnSe, uncoated	SP90336
PY-IV-W-POLY-THZ	Pyrocam IV window assembly, LDPE, uncoated for Terahertz wavelengths	SP90309

3.3.5 BeamMic™ - Basic Laser Beam Analyzer System

- High-speed false color beam intensity profile displays in both 2D and 3D
- Operates in Windows 7 and Windows 10
- Numerical beam profile analysis employs patented advanced calibration algorithms
- Extensive set of ISO quantitative measurements
- ISO beam width and diameter methods
- Enhanced window layout tools to get the most out of the desktopdisplay area
- Pass/fail testing available on most all measured parameters
- Support for USB SPxxx series cameras
- Supports satellite windows on multiple monitors
- Continuous zoom scaling in both 2D and 3D
- Results logging capabilities exportable to Excel
- Industry std data file formats, HDF5 and CSV
- Configurable Report Generator that allows cut and paste of results, images and settings from .PDF and .XPS file types
- Statistical Analysis of all measured parameters
- Both Drawn and Auto Aperture for isolating beam data
- Integrated automatic Help linked into this .pdf Users Guide
- Automation interface via .NET components

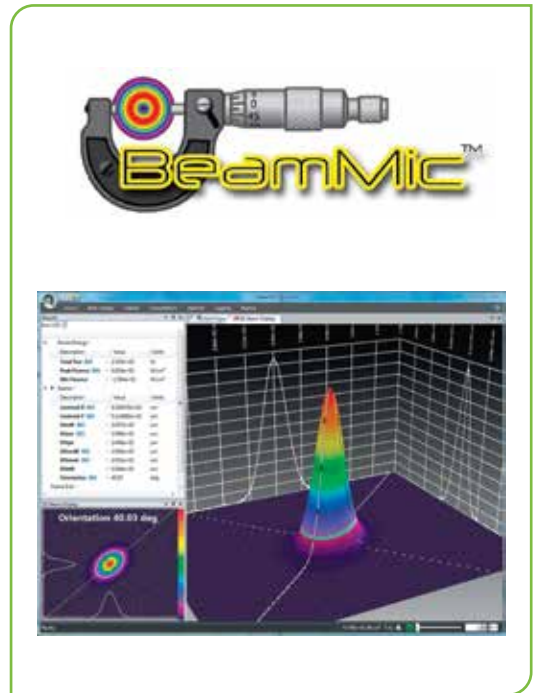

BeamMic is an introductory product for those that do not need all of the features in our award winning beam profiling product, BeamGage. BeamMic includes a simplified set of measurements allowing for basic beam characterization to help improve your system performance without going to a full-featured SPC type system. This is perfect for the operator to do a quick check on the laser system prior to starting their process. BeamMic meets many of our industrial customer’s basic needs at a cost effective price.

The beam’s size, shape, uniformity or approximation to the expected power distribution, can make or break an application. Accurate knowledge of these parameters is essential to the accuracy of any laser-based application. As laser applications push the boundaries of laser performance it is becoming more critical to understand the operating criteria.

BeamMic Main Display Screen

File Save/Load ApplicationButton

Tabbed Control Access

Beam Results With Statistics

ISO Compliant Results

3D Beam Display

Integrated Help System

2DBeam Display

Tool Windows that dock inside or float outside App

Processing Status Indicators

Buffered Video Scrolling Controls

3.3.5.1 Software Specifications

Features	BeamMic - Laser Beam Analyzer Software
Features Overview	<p>Designed for entry level or basic profiling needs</p> <p>Supports our patented Ultracal algorithm plus Auto-setup and Auto-exposure capabilities</p> <p>Extensive set of ISO quantitative measurements</p> <p>Support for high and low resolution USB cameras</p> <p>Simultaneous 2D and 3D displays</p> <p>Multi-instance, multi-camera use</p> <p>Supports Satellite windows on multiple monitors</p> <p>Continuous zoom scaling in both 2D and 3D</p> <p>Camera ROI support</p> <p>Manual and Auto-aperturing to reduce background effects</p> <p>Pass/Fail on all results items, w/multiple alarm options</p> <p>Results logging capabilities in a reloadable</p> <p>Industry standard data file format</p> <p>Configurable Report Generator that allows cut and paste of results, images and settings.</p> <p>Supports English, German, Japanese and Chinese Windows OS in 64bit . Multilingual GUI in English, Japanese and Chinese.</p>
Quantitative Calculations; Basic Results	(per ISO 11145, 11146-1/-3, and 13694)
Power/Energy Results	<p>Total power or energy</p> <p>Peak power/energy density</p> <p>Min. Fluence</p>
Spatial Results	<p>Peak and Centroid locations</p> <p>Beam width</p> <ul style="list-style-type: none"> • Second Moment (D4s) • Knife Edge 90/10 • Knife Edge (User selectable level) • Percent of Peak (User selectable) • Percent of Total Energy (User selectable) • Encircled power smallest slit @ 95.4 • Moving Slit (User Selectable) <p>Beam diameter</p> <ul style="list-style-type: none"> • Average diameter (based on x/y widths) • Second Moment (D4s) <p>Elliptical Results</p> <ul style="list-style-type: none"> • Elliptical orientation • Ellipticity • Eccentricity
2D Features	<p>Continuously zoomable and resizable displays in satellitable window</p> <p>Continuous Z axis display magnitude scaling</p> <p>Zoomable to subpixel resolution for origin and cursor placements</p> <p>Pixel boundaries delineated at higher zoom magnifications</p> <p>Adjustable Cursors that can track peak or centroid</p> <p>Adjustable manual apertures</p> <p>Viewable Auto-aperture placement</p> <p>Displayed beam width marker</p> <p>Integrated Mouse actuated pan/zoom controls</p> <p>Manual or fixed origin placement</p>
3D Features	<p>3D graphics utilize solid surface construction with lighting and shading effects</p> <p>Integrated Mouse actuated pan/zoom/tilt/rotate controls</p> <p>Selectable Mesh for drawing speed vs resolution control</p> <p>Continuously zoomable and resizable displays in satellitable window</p> <p>Continuous Z axis display magnitude scaling</p> <p>User enabled backplanes with cursor projections</p>
Statistical Analysis	<p>Performed on all measurement functions with on-screen display</p> <ul style="list-style-type: none"> • Choices of intervals • Manual start/stop • Time from 1 second to 1000 hours • Frames from 2 to 99,999 <p>Measurements reported</p> <ul style="list-style-type: none"> • Current frame data, Mean, Standard Deviation, Minimum, Maximum of each calculation performed
File types	<p>Industry Standard HDF5 data and setup file format which are compatible in third party applications such as MatLab and Mathematica</p> <p>Math program and Excel compatible ASCII-csv results files</p> <p>Graphics in jpg file format</p> <p>A user defined single file output that can contain settings, beam displays, beam profiles, results in either .pdf or .xps file formats</p>
Printing	<p>Images, reports, results, statistics and setup information</p> <p>Option to print many frames in a single operation</p> <p>WYSIWYG images</p>
Pass/Fail	<p>Set Maximum/Minimum limits on all calculations and statistics</p> <p>Red/Green font color indication on result items</p> <p>Multiple choices for indication of failed parameters, including TTL pulse for external alarm</p> <p>Master pass/fail which triggers alarm on any failure</p> <p>USB signal, beep, stop, and log alarm options</p>
Logging	<p>Results in ASCII-csv</p> <p>Continuous Logging</p> <p>Time Interval Logging</p> <p>Frame Count Logging</p> <p>Pass/Fail Sampling</p>

Features	BeamMic - Laser Beam Analyzer Software
Exporting	Convert frame buffer data to third party format
	Export a user specified number of frames from the buffer
	Export Image Data: ASCII-cvs
	Export Results: ASCII-csv
	Export Picture: jpg, gif, tiff, bmp, png file formats supported
	Export Image Data in Aperture
Integrated Help	PDF Operators Manual
	Context Sensitive - "Whats this?" Help
	Context Sensitive Hints
Signal Conditioning for Enhanced Accuracy	Spiricon's patented Ultracal enables more accurate beam measurement and display. Ultracal takes a multi- frame average of the baseline offset of each individual pixel to obtain a baseline accurate to approximately 1/8 of a digital count. This baseline offset is subtracted from each frame, pixel by pixel, to obtain a baseline correction accurate to 1/8 digital count. Spiricon's Ultracal method retains numbers less than zero that result from noise when the baseline is subtracted. Retaining fractional and negative numbers in the processed signal can increase the beam width measurement accuracy by up to 10X over conventional baseline subtraction and clip level methods. Spiricon's Ultracal conforms to the best method described in ISO 11146-3:2004
Frame averaging	Up to 256 frames can be averaged for a signal-to-noise ratio, S/N, improvement of up to 16X (Noise is averaged up to 1/256th [8 fractional bits]). Data is processed and stored in a 32bit format
Frame Summing	Up to 256 frames can be summed to pull very weak signals out of the noise. Due to the precise nature of Ultracal baseline setting, (i.e., a retention of both positive and negative noise components) summing of frames can be performed without generating a large offset in the baseline
Convolution (Adjacent Pixel Averaging)	Choice of 5 convolution algorithms for spatial filtering for both display and calculations. Spatial filtering improves the visual S/N
Camera Features	Camera features are governed by the capabilities of the various cameras that will interface with these software products, and second by which of these camera features are implemented in the software. This section will describe typical camera features supported in the application
	Black Level Control (used by Ultracal and Auto-X and Auto-setup)
	Gain Control (used by Auto-X and Auto-setup)
	Exposure Control (used by Auto-X and Auto-setup)
	Pixel Sampling
	Bits per pixel setting
	External Trigger Input
	Trigger Delay
	Strobe Output
	Strobe Delay
	External Trigger Probe
	Internal Trigger Probe
Camera related features in the applications	These are features related to but not generally dependent upon the camera design
	Gamma Correction
	Gain Correction
	Bad Pixel Correction
	Lens Applied Option
	Pixel scale settings
	Magnification settings
	Frame buffer settings
	Ultracal
	Enable Auto-X (auto exposure control)
	Perform an Auto-Setup
	8 & 12 bits per pixel
	Select Format
	Measure S/N ratio
Trigger, Capture and Synchronization Methods	Capture methods are features related to the application while Synchronization methods relate more to the abilities of the specific camera. NOTE: Frame capture rates are determined by many factors and are not guaranteed for any specific operating configuration.
	Trigger modes
	• CW - captures continuously, see Capture Options below
	• Trigger-In from laser: Trigger pulses supplied to the camera
	• Strobe-Out to laser: Strobe pulses output from the camera
	• Video Trigger: Frame captured and displayed only when the camera sees a signal greater than a user set level
	Capture options
	• Capture options are redefined and are approached in a different manner than older products. The items listed below will allow for all of the previous methods but with more flexibility than ever before
	• Results Priority: Results priority will slow the capture rate to be in sync with the computational results and display updates
	• Frame Priority: Frame priority will slow results and display updating to insure that frames are collected and stored in the frame buffer as fast as possible (replaces block mode)
	• Stop After: Will collect a set number of frames and then stop (replaces Single-Shot mode)
	• Periodic: Will collect frame at a programmed periodic rate
	• Periodic Burst: Will collect frames in a Burst at programmed periodic rates
	• Post processing is still available but is done via a different mechanism and is limited to only data file sources
Automation Interface (.NET)	Automation Interface with examples in LabVIEW, Excel and Net VB
	Automate launch and termination of the application
	Automate start, stop, Ultracal, Auto-X and Auto Setup
	Automate the loading of application setups
	Automate control of most camera settings
	Automate a subset of the application features and controls
	Automate the capture of Binary Video Data
	Automate the acquisition of application results
	Automate the acquisition of application Images
System Requirements	PC computer running Windows 7 and Windows 10 Laptop or Desktop
	GHz Pentium style processor, dual core recommended
	Minimum 2GB RAM
	Accelerated Graphics Processor
	Hard drive space suitable to hold the amount of video data you expect to store (50-100 GB recommended)

Ordering Information

Item	Description	P/N
BeamMic™ USB3 Beam Analyzer Systems (camera and software)		
BM-USB3-SP932U	BeamMic software, software license, 1/1.8" format 2048X1536 pixel camera with 4.5mm CMOS recess. Comes with USB 3.0 cable, Trigger cable and 3 ND filters	SP90608
BM-USB3-SP203P	BeamMic software, software license, 1/1.8" format 2048 x 1536 pixel camera with 4.5mm CMOS recess. Phosphor coated to 1550 nm. Comes with USB cable and 3 ND filters	SP90638
Software Upgrades		
BeamMic to BGS Upgrade	Upgrade BeamMic to BeamGage Standard Edition. Requires a camera key to activate. (SP cameras may require a firmware upgrade to enable ROI features)	SP90316
BeamMic to BGP Upgrade	Upgrade BeamMic to BeamGage Professional Edition. Requires a camera key to activate (SP cameras may require a firmware upgrade to enable ROI features)	SP90317
Optical Synch for Pulsed Lasers		
Photodiode Trigger, Si, 1100	Optical trigger assembly which can be mounted on camera or separately to sense laser pulses and synchronize SP cameras with pulses. See optical trigger data sheet	SP90408
Recommended Optional		
LBS-300s-BB	Dual beam splitters and configurable 9 ND filters for 190-1550nm; screws onto front of camera	SP90467

3.3.5.2 Cameras for BeamMic™

Camera Compatibility

- For lasers between 190-1100nm wavelengths, BeamMic interfaces to both silicon CCD and CMOS USB cameras.
- For applications between 1440-1605nm, BeamMic supports cost effective phosphor coated CCD cameras.

190-1100nm



Model	SP932U
Application	1/1.8" format, slim profile, wide dynamic range, CW & pulsed lasers, adjustable ROI
Beam sizes	34.5µm - 5.3mm
Number of effective pixels	2048 x 1536
CMOS recess	4.5±0.11mm
PC interface	USB 3.0
Page in the catalog	228

* May be useable for wavelengths below 300nm but sensitivity is low and detector deterioration may occur. Therefore UV image converter is recommended.

1440-1605nm



Model	SP203P
Application	SWIR wavelengths, 1/1.8" format
Beam sizes	600µm - 5.3mm
Number of effective pixels	2048 x 1536
Recess	4.5mm ±0.11mm
PC interface	USB 3.0
Page in the catalog	231

3.3.6 Focal Spot Analyzer

Captures the beam size, shape and profile at focus

- Image focal spots down to 34.5µm in size
- For laser powers up to 400W ⁽¹⁾ (additional external ND filters required) and up to 5kW for FSA- HP version
- Can measure systems with focal length as short as 73mm ⁽²⁾ (exact path length distance within the assembly will be NIST/National Lab calibrated and includes a calibration certificate +/-50µm)
- Produces undistorted sample of laser under test
- Adjustable attenuation maximizes system dynamic range
- Up to 1 x 10⁻¹⁰ attenuation available (without external filters)
- Analyzer includes camera, attenuation, BeamGage software and calibration certificate



Measure your laser beam power distribution and focal spot size of wavelengths from 300 – 1100nm. The average power can be from <1 to 400 Watts and up to 5 kW for FSA-HP, the focal spot can be as small as 34.5µm. The FSA can also be used to measure how the focal spot shifts with power during its critical start-up phase. The FSA is a combination of a camera, Beam Splitter, natural density filters and a BeamGage software.

FSA-HP

For measurement of focal position and profile of high power lasers above 1kW at NIR (~1064nm) region, FSA-HP version can be used. It allows same operation as standard FSA but operates up to 5kW or 15MW/cm² without significant heating.

Only 0.0001% (1/10⁶) of the incident beam is reflected

(1) For Gaussian beam diameter <1/2 the clear aperture and depending on ND filter and camera saturation limits the maximum power may be as high as 1000W.
 (2) Using beam expanders, focal spots as small as 10µm can be measured and calibrated, Ask your Ophir representative about special calibrated focal spot analyzers.

towards Ophir Beam Profiler, enabling beam sampling of extremely high powers and power densities.

Operation

The assembly is placed below the final focusing lens of the laser at a distance equal to the expected focal length less the ~73mm of the calibrated distance, so the beam will be focused on the camera layer. The focal spot is found by moving the assembly closer and farther from the beam until the smallest spot size is seen. The distance between the focusing lens and the datum point on the FSA assembly is added to the distance from the datum to the camera array (each FSA assembly will be factory calibrated to within +/- 50 µm). These two measurements will give you the exact distance of your lasers focal spot.

Examples of Usage

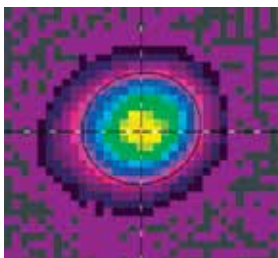

65µm diameter focal spot

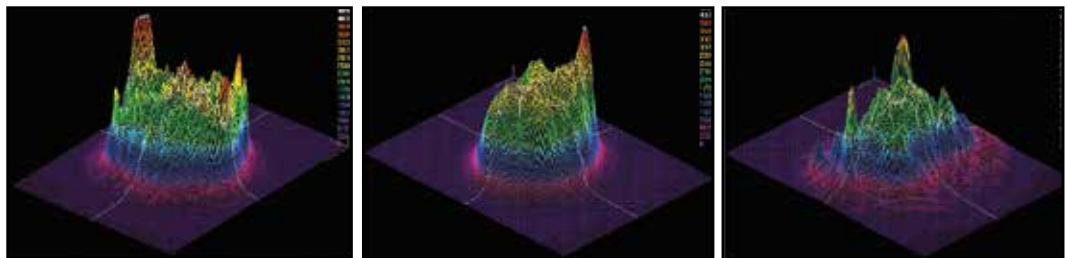

Focal spot spatial power density changing with laser power level

FSA-SP932U

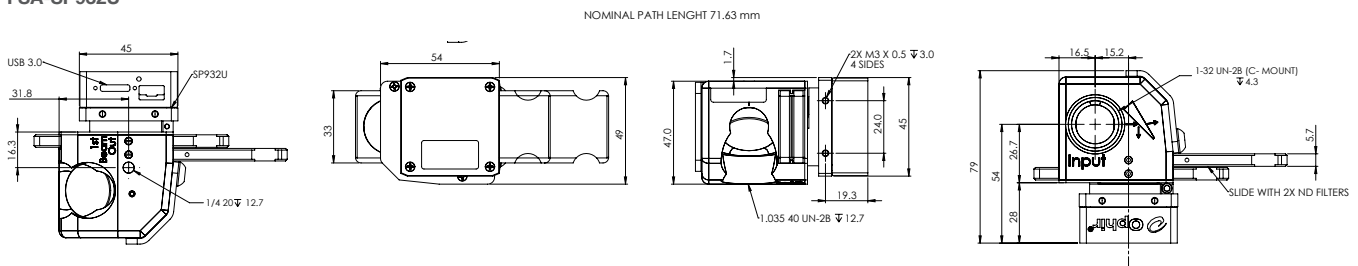

Cameras Specifications

Model	SP932U	LT665
Format	1/1.8"	1"
Wavelengths ⁽¹⁾	190 - 1100nm	190 - 1100nm
Active Area	7.06mm x 5.3mm	12.5mm x 10mm
Beam sizes	34.5µm - 5.3mm	46µm - 9.9mm
Pixel spacing	3.45µm x 3.45µm	4.54µm x 4.54µm
Number of effective pixels	2048 x 1536	2752 x 2192
Dynamic range	72 dB	54 dB
Linearity with Power	±1%	±1%
Accuracy of beam width	±2%	±2%
Frame rates in 12 bit mode ⁽²⁾	24 fps at full resolution	27 fps at full resolution
Shutter duration	25µs to 2000ms	31µs to multiple frames
Gain control	1.46 dB to 256 dB	0.8 dB to 56 dB
Trigger	Hardware/Software trigger & strobe out	Hardware/Software trigger & strobe out
Photodiode trigger (Optional) ⁽³⁾	Si response: SP90408	Si response: SP90408
Saturation intensity ⁽⁴⁾	32µW/cm ² at 632nm, 500µW/cm ² at 1064nm	14µW/cm ²
Lowest measurable signal ⁽⁴⁾	0.2nW/cm ²	0.3nW/cm ²
Damage threshold ⁽⁵⁾	50W/cm ² / 1J/cm ² with all filters installed for < 100ns pulse width	50W/cm ² / 1J/cm ² with all filters installed for < 100ns pulse width
Dimensions	45mm x 45mm x 22.5mm	43mm x 43mm x 65mm
Imager recess	4.5mm	17.5mm
Image quality at 1064nm	Pulsed with trigger sync - excellent Pulsed with video trigger - good CW - good	Pulsed with trigger sync - excellent Pulsed with video trigger - good CW - good
Operation mode	CMOS, Global shutter	Quad Tap interline transfer CCD
PC interface	USB 3.0	USB 3.0
OS Supported	Windows 7 (64) and Windows 10	Windows 7 (64) and Windows 10
Compliance	CE, UKCA, China RoHS	CE, UKCA, China RoHS

Notes: (1) The camera's natural response is from 340nm through 1100nm. To measure effectively below 340nm, please make use of one of our UV converters. Otherwise the sensitivity is too low and the measurement accuracy may degrade.
(2) Highly dependent on PC processor and graphics adapter performance.
(3) For more information please see "Optical Camera Trigger" catalog page.
(4) Camera set to full resolution at maximum frame rate at 633nm CW wavelength. Camera set to minimum useful gain and 1ms exposure time for saturation test and maximum useful gain and 35ms exposure time for lowest signal test.
(5) This is the damage threshold of the filter glass of the filters. Assuming all filters mounted with ND1 (red housing) filter in the front. Distortion of the beam may occur with average power densities of 5W/cm² for beam size 5mm, 10W/cm² for 2mm beam and >30W/cm² for 1mm beam.

LBS -300s Specifications

Model	LBS-300s-UV	LBS-300s-VIS	LBS-300s-NIR	LBS-300HP-NIR	LBS-300s-BB
Wavelengths ⁽¹⁾	266-355nm	400-950nm	950-1800nm	1000-1100nm	190-2500nm
Wedge Material	UVFS	UVFS	UVFS	UVFS	UVFS
Wedge Coating	A/R ≤1%	AR ≤1%	AR ≤1%	AR ≤0.1% special surface	No coating, 4% reflection
Clear aperture	17.5mm	17.5mm	17.5mm	15mm	17.5mm
Reflection ⁽¹⁾⁽²⁾	0.01%	0.01%	0.01%	<0.0001% (1/10 ⁶)	0.16%
Wedge ND value, each	ND ≥2	ND ≥2	ND ≥2	ND ≥3	ND ~1.3
Maximum allowable input to wedge	1MW/cm ² 5 J/cm ²	1MW/cm ² 5 J/cm ²	1MW/cm ² 5 J/cm ²	15MW/cm ² , 10J/cm ² at beam splitter	10MW/cm ² 20 J/cm ²
ND Filters	Inconel	Bulk ND	Bulk ND	Bulk ND	Combination of Inconel and Bulk ND
ND Values, nominal	0.3, 0.7, 1.0, 2.0, 3.0, 4.0 (Blue holders)	0.3, 0.7, 1.0, 2.0, 3.0, 4.0 (Green holders)	0.4, 0.8, 1.0, 2.0, 3.0, 4.0 (Red holders)	0.4, 0.8, 1.0, 2.0, 3.0, 4.0 (Red holders)	10 filters UV, VIS and NIR
Filter Slides	3	3	3	3	5
Maximum allowable input to filter ⁽³⁾	100 W/cm ² CW 20mJ/cm ² , 10ns pulse	50 W/cm ² 1J/cm ² , 10ns pulse	50 W/cm ² 1J/cm ² , 10ns pulse	50 W/cm ² 1J/cm ² , 10ns pulse	See UV, VIS and NIR specifications

Notes: (1) The Wavelengths and Reflection refer to Wedges of LBS-300s Assembly used in FSA unit. The standard FSA operating wavelengths is limited by SP932U camera 300-1100nm, in case extending spectral region is required, contact your Ophir representative.
(2) For reflectance Spectra see LBS-300 User Note.
(3) This is the damage threshold of the filter glass of the filters. Distortion of the beam may occur with average power densities of 5W/cm² for beam size 5mm, 10W/cm² for 2mm beam and >30W/cm² for 1mm beam

Ordering Information

Model	SP932U	LT665		
	Item	P/N	Item	P/N
LBS-300s-UV	FSA-UV-SP932U	SP90614	BGP-LBS-300s-UV-CAL-LT665	SP90481
LBS-300s-VIS	FSA-VIS-SP932U	SP90615	BGP-LBS-300s-VIS-CAL-LT665	SP90482
LBS-300s-NIR	FSA-NIR-SP932U	SP90616	BGP-LBS-300s-NIR-CAL-LT665	SP90483
LBS-300s-BB	FSA-BB-SP932U	SP90617	BGP-LBS-300s-BB-CAL-LT665	SP90484
LBS-300HP-NIR	FSA-HP-NIR-SP932U	SP90603		

Note: Comes with BeamGage Professional software license, NIST/ National Lab traceable calibrated path length from top of unit to CCD array, USB cable and 3 ND filters.

3.4 Introduction to Scanning-Slit Profilers

The scanning slit beam profiler moves two narrow orthogonal slits in front of a linear photo-detector through the beam under analysis. Light passing through the slit induces a current in the detector. Thus, as the slit scans through the beam, the detector signal is linearly proportional to the spatial beam irradiance profile integrated along the slit. A digital encoder provides accurate slit position. The photo-induced current signal is digitized and analyzed to obtain the beam profile in both X and Y from the two orthogonal slits. The slit apertures act as physical attenuators, preventing detector saturation for most beam applications. High dynamic range amplification allows operation over many orders of magnitude in beam power.

From these profiles, important spatial information such as beam width, beam position, beam quality, and other characteristics are determined. This technique can accommodate a wide variety of test conditions. Because slit scanners measure beams at high powers with little or no attenuation, they are ideal to profile beams used in material processing.

Carbon dioxide (CO₂) lasers are widely used in materials processing, and have a 10.6 micron wavelength that cannot be profiled with most cameras. Slit scanners, therefore, provide a convenient means of measuring high-resolution CO₂ lasers with powers up to and exceeding 1000 watts.



NanoScan Scanhead

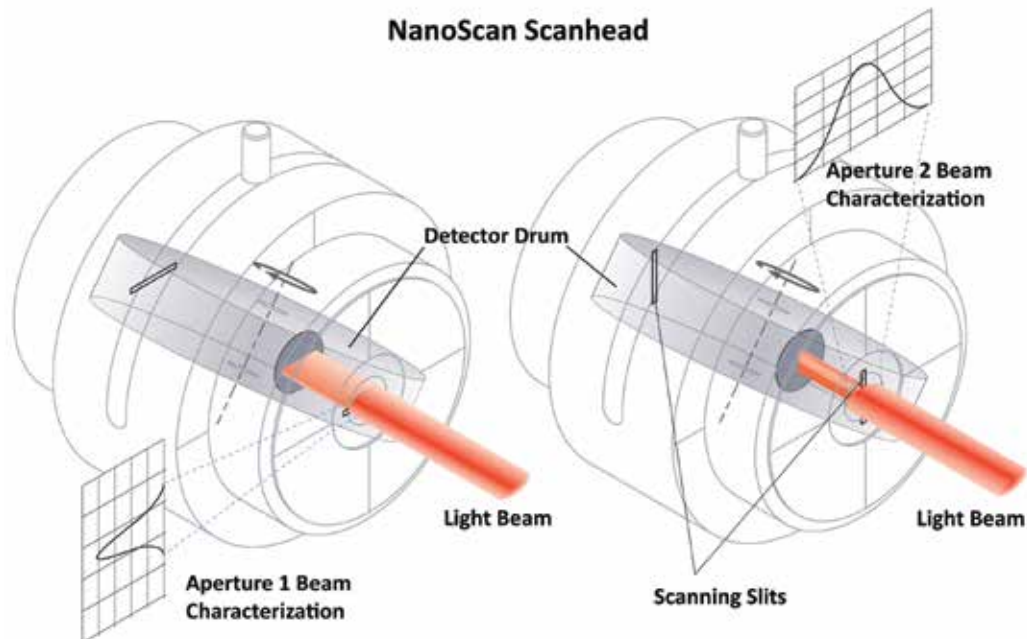

3.4.1 NanoScan 2s

Scanning Slit Beam Profiler For High Accuracy Dimensional Measurement

NanoScan 2s combines the convenience and portability of direct USB connectivity with the speed, accuracy, and dynamic range that users have come to expect from the Photon NanoScan slit based profilers. The NanoScan 2s is available with a silicon, germanium or pyroelectric detector, which allows it to profile lasers of any wavelength from UV to far infrared, out to 100 μ m and beyond. With the new NanoScan 2s software package, the user can configure the display interface however it is desired; displaying those results of most interest on one easy-to-read screen, or on multiple screens.

The NanoScan slit profiler is the most versatile laser beam profiling instrument available today: providing instantaneous feedback of beam parameters for CW and kilohertz pulsed lasers, with measurement update rates to 20Hz. The natural attenuation provided by the slit allows the measurement of many beams with little or no additional attenuation. The high dynamic range makes it possible to measure beams while adjustments to focus are made without having to adjust the profiler. Just aim the laser into the aperture and the system does the rest!

Capabilities

NanoScan 2s is a PC-based instrument for the measurement and analysis of laser beam spatial irradiance profiles in accordance with the ISO standard 11146. The scan heads also measure power in accordance with ISO 13694. NanoScan uses the scanning slit, one of the ISO Standard scanning aperture techniques. It can measure beam

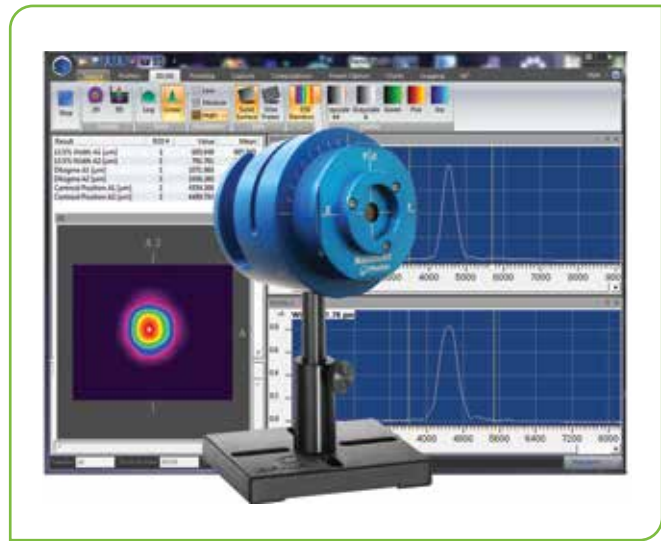

sizes from microns to centimeters at beam powers from microwatts to over kilowatts, often without attenuation. Detector options allow measurement at wavelengths from the ultraviolet to the infrared.

The NanoScan 2s digital controller has 16-bit digitization of the signal for enhanced dynamic range up to 35dB power optical. With the accuracy and stability of the beam profile measurement you can measure beam size and beam pointing with a 3-sigma precision of several hundred nanometers. The software controllable scan speed and a “peak-connect” algorithm allows the measurement of pulsed and pulse width modulated lasers with frequencies of 10kHz and higher*. The NanoScan is also able to measure up to 16 beams, or regions of interest, in the aperture simultaneously.

Benefits

- Measure any wavelength from UV to very far infrared (190nm to >100 μ m)
- Instantaneous real time display of results; beam found in less than 300ms and updated at up to 20Hz
- Waist location can be determined to within $\pm 25\mu$ m due to the well-defined Z-axis datum plane of the NanoScan
- Measure pulsed and CW lasers
- For pulsed beams the pulse rate is measured and reported
- From as small as 7 μ m beams, can be measured directly with guaranteed accuracy and precision
- Additional high signal to noise ratio can be achieved with averaging

- Z-axis caustic measurements are available with built-in mechanical linear stage control
- M^2 propagation ratio values available with simple M^2 Wizard included with the software.
- Any beam result can be charted and monitored over time
- Power levels can be monitored along with spatial measurements to determine if losses are introduced by beam adjustments
- Log results to text files for independent analysis
- Automate the system using optional ActiveX Automation commands, available with the PRO version software and scan heads Samples of automation programs included for Excel, VBA, LabView and Visual Basic.net

* The minimum frequency is a function of the beam size and the scan speed. This is a simple arithmetic relationship; there must be a sufficient number of pulses during the time that the slits sweep through the beam to generate a meaningful profile. Please refer to Photon's Application Note, Measuring Pulsed Beams with a Slit-Based Profiler.

NanoScan 2s Configurable User Interface

In addition to new hardware, the NanoScan 2s has an updated integrated software package for the Microsoft Windows Platform, which allows the user to display any of the results windows on one screen. The NanoScan 2s software comes in two versions, STD and PRO. The NanoScan 2s Pro version includes ActiveX automation for users who want to integrate the NanoScan into OEM systems or create their own user interface screens with C++, LabView, Excel or other OEM software packages.

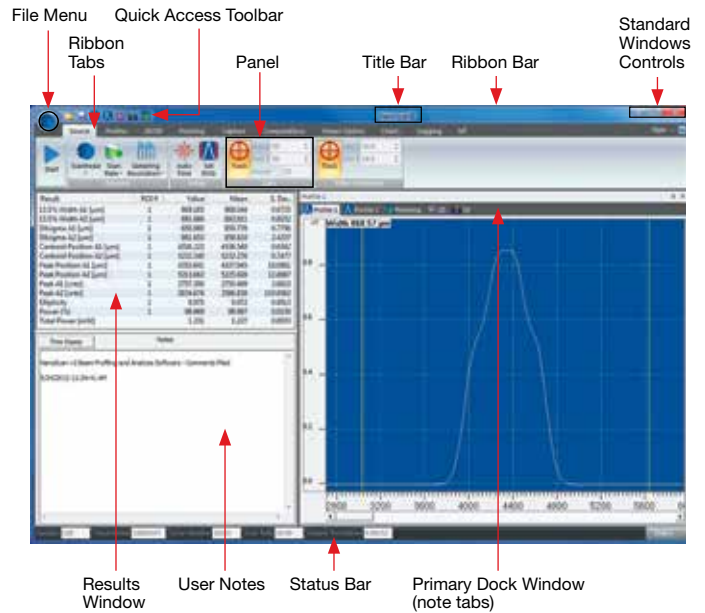

See Your Beam As Never Before

The new NanoScan 2s graphical user interface (GUI) allows the user to set the display screens to any appropriate configuration, displaying those that are of interest and hiding what is not. This means that you can have the information that you want to see, uncluttered by extraneous output, and

you can have all the features you need, visible at once. The screens can be docked or floating with ribbon bars for the controls that can be visible or hidden as desired. This allows you to take advantage of a large, multi-monitor desk top or maximize the useful information on a small laptop display.

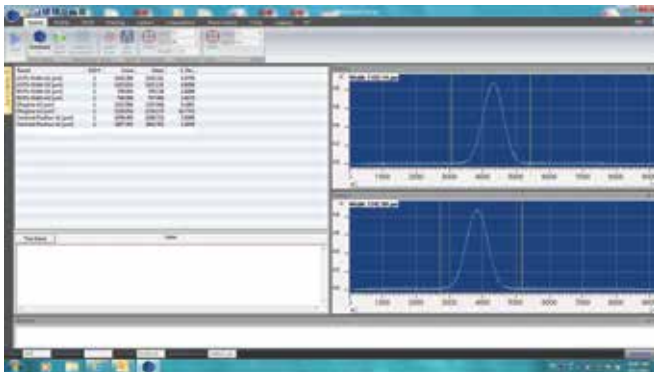

Simple docked view of profiles and numerical results

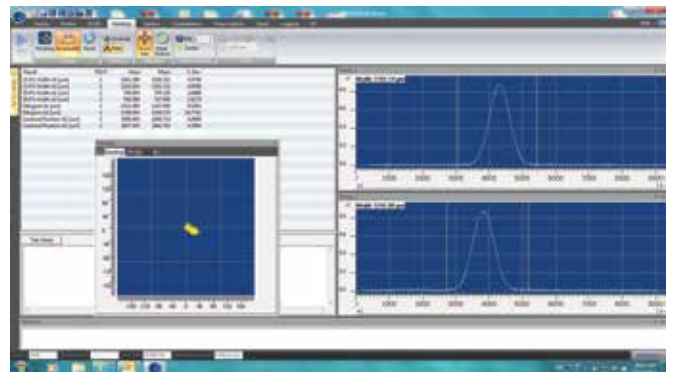

Both docked and undocked windows: profiles, results, and pointing



Example of time charts used to monitor focusing process

Integrated Power Meter

The silicon and germanium detector equipped NanoScan 2s systems include an integrated 200mW power meter. The scanhead comes with a quartz attenuator window that provides a uniform response across a broad wavelength range. This is a relative power meter that has better than 1.5% correspondence when calibrated with a user-supplied power meter and used in the same configuration as calibrated. The power meter screen in the software shows both the total power and the individual power in each of the beams being measured.

Available Detectors

The NanoScan 2s is available with silicon, germanium or pyroelectric detectors to cover the light spectrum from UV to very far infrared.

Apertures and Slits

The NanoScan 2s is available with a variety of apertures and slit sizes to allow for the accurate measurement of varying beam sizes. The slit width defines the minimum beam width that can be measured; due to convolution error, the slit should be no larger than $\frac{1}{4}$ the beam diameter to provide a $\pm 3\%$ accurate measurement. For this reason the minimum beam diameter measurable with the standard $5\mu\text{m}$ slit is

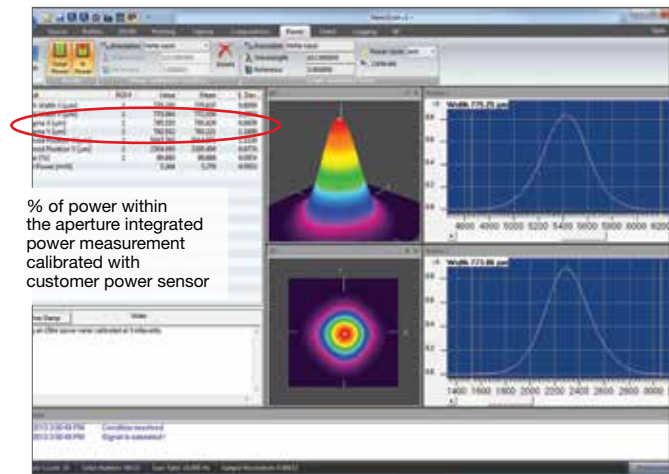

20 μm . To measure beams smaller than 20 μm it is necessary to use the small aperture 1.8 μm slit instrument, providing a minimum beam diameter of $\sim 8\mu\text{m}$. Because these slits are so narrow, the maximum length limits the aperture to 3.5mm. Contrary to many people's beliefs, these smaller slits do not improve the resolution of the measurement, only the minimum size of the beam. Therefore, unless it is necessary to measure beams less than 20 μm , one would be advised to stick with the 9mm/5 μm configurations.

The Most Versatile and Flexible Beam Profiling System Available

With the available range of detectors, slit sizes and apertures the NanoScan 2s provides the maximum versatility in laser beam profiling. NanoScan 2s adds the convenience and portability of direct USB connectivity: no external controllers or power supplies required to operate the profiler. In addition the rotation mount has been redesigned to provide a stand for vertical operation, if desired. The mount can be positioned in one of two places. If vertical operation is desired the mount is positioned toward the back of the scanhead to expose the stand, which can be affixed to the optical table or stage. If standard horizontal operation is desired, then the rotation mount can be positioned in the forward configuration, maintaining the original length and size of the scanhead.



For Higher Powers, Teams up the NanoScan with the LBS-300s

In order to measure powers and energies above the limits of the NanoScan, an LBS-300s of the appropriate wavelength range can be attached to the front of the NanoScan and measure powers up to 1000W and more. The C mount thread of the LBS-300s mates with the C mount thread of the NanoScan. There are various models of the LBS-300s ranging in wavelength from 190nm up to 1550nm and beyond. Alternatively, the Stackable Beam Splitters can be attached to the NanoScan and used to attenuate high power beams.



Measured Beam Results

From 1989 through 1996, John Fleischer, founder and past President of Photon Inc., chaired the working laser beam width ISO/DIN committee that resulted in the ISO/DIN 11146 standard. The final approved standard, available in 13 languages. The standard governs profile measurements and analysis using scanning apertures, variable apertures, area sensors and detector arrays. NanoScan 2s measures spatial beam irradiance profiles using scanning slit techniques.

Results measured include:

- Beam Width at standard and user-definable clip levels, including $1/e^2$ and 4σ
- Centroid Position
- Peak Position
- Ellipticity
- Gaussian Fit
- Beam Divergence
- Beam Separation
- Pointing Stability
- ROI Power
- Total Power
- Pulsed Laser Repetition Rate

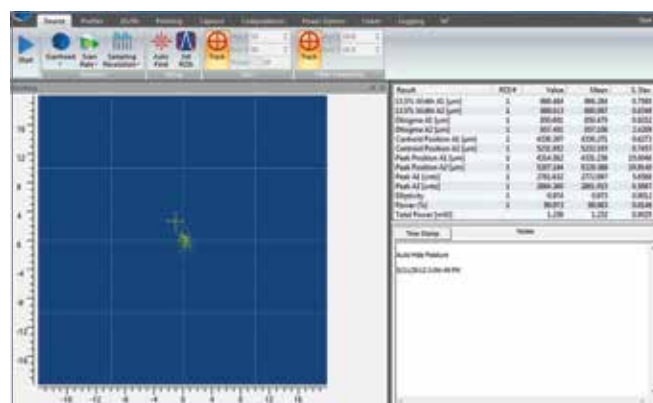

Knowing pointing stability is a critical factor in laser performance

Result	ROI #	Value	Mean	S. Dev.
13.5% Width A1 [μm]	1	863.328	864.612	0.7082
13.5% Width A2 [μm]	1	876.317	875.622	0.9432
D4sigma A1 [μm]	1	849.062	849.700	1.5084
D4sigma A2 [μm]	1	842.054	840.924	2.3751
Centroid Position A1 [μm]	1	1.111	-0.133	0.5622
Centroid Position A2 [μm]	1	-1.730	0.275	1.2221
Peak Position A1 [μm]	1	-11.521	-19.890	5.6014
Peak Position A2 [μm]	1	4.156	8.732	6.9860
Peak A1 [cnts]	1	2812.438	2810.688	4.0486
Peak A2 [cnts]	1	2687.898	2678.320	5.5879
Ellipticity	1	0.806	0.807	0.0023
Power [%]	1	99.994	99.979	0.0273
Total Power [mW]		1.202	1.203	0.0002

Example of the many measurements that can be made and the precision you can expect

M² Wizard

M-squared (M²) software Wizard is an interactive program for determining the “times diffraction limit” factor M² by the Rayleigh Method. The M² Wizard prompts and guides the user through a series of manual measurements and data entries required for calculating M².

Used with a user-provided translation stage focusing lens and the M² Wizard in the NanoScan Analysis Software, the user can quickly and easily determine the times-diffraction propagation factor (M²) of a laser. For automated and automatic M² measurements the NanoModeScan option is required.

Pulsed Laser Beam Profiling

In addition to profiling CW laser beams, NanoScan can also profile pulsed laser beams with repetition rate in the 10kHz range and above. To enable the measurement of these pulsed lasers, the NanoScan profiler incorporates a “peak connect” algorithm and software-controlled variable scan speed on all scanheads. The accuracy of the measurement generally depends on the laser beam spot size and the pulse-to-pulse repeatability of the laser. The NanoScan is ideal for measuring Q-switched lasers and lasers operating with pulse width modulation power (PWM) control. In the past few years, lasers with pico and femtosecond pulse durations have begun to be used in many applications. Although these lasers add some additional complication to the measurement techniques, the NanoScan can also measure this class of laser.

3.4.1.1 Software Comparison Chart

Use the Software specification from the existing NanoScan 2s data sheet

*Feature		NanoScan Standard	NanoScan Professional
Controls			
Source	ScanHead Select, Gain, Filter, Sampling Resolution, AutoFind, Rotation Frequency, Record Mode	•	•
Capture	Averaging, Rotation, Magnification, CW or Pulse Modes, Divergence, Gaussian Fit, Reference Position, Recompute	•	•
Regions of Interest (ROI)	Single or Multiple, Automatic or Manual, Colors	•	•
Profiles	Vertical Scale (1', 10', 100'), Logarithmic Scale, Z & PAN (Automatic or Manual)	•	•
Computation: ISO 13694, ISO 11146	D _{site} , (13.5%, 50% 2 User Selectable Clip Levels), D _{4σ} , Width ratios, Centroid Position, Peak Position, Centroid Separation, Peak Separation, Irradiance, Gaussian Fit, Ellipticity, Divergence, Total Power, Pulse Frequency, % power	•	•
	Continuous, Rolling, Finite	•	•
Pointing	Centroid or Peak, Accumulate Mode, Beam Indicator, Graph Center, Colors	•	•
2D/3D	2D or 3D Mode, Linear or Logarithmic Scale, Resolution, Fill Contours, Solid Surface, or Wireframe, Clip Level Colors	•	•
Charts	Chart Select, Parameter Select, Aperture Select, Update Rate, Start and Clear	•	•
Logging	File Path/Name, Delimiter, Update Rate	•	•
M ²	Rail Setup: Com Port and Length, Connect/Disconnect, Rail Control	•	•
Views			
Profiles	Displays Beam Profiles for each axis, with optional Gaussian Overlays	•	•
Results	Displays Values and Statistics for Selected results	•	•
Pointing	Displays the XY position of the Centroid or Peak for each ROI, with optional overlays and Accumulate Mode	•	•
Charts	Displays Time Charts for User-selected results	•	•
2D/3D	Displays pseudo 2D/3D Beam Profile	•	•
M ² Wizard	An interactive procedure for measuring M ² by the Rayleigh Method	•	•
File Saving			
NanoScan Data Files		•	•
Text Files		•	•
Data Logging			
Log to File		•	•
Reports			
NanoScan Report		•	•
Automation Interface			
ActiveX Automation Server			•
Minimum System Requirements			
PC computer running windows 7 (32/64) Laptop or Desktop			
A dual core processor CPU, 2GHz or better			
2GB of RAM			
1-USB 2.0 port available			
At least 250MB of free HDD space			
1400 x 900 display resolution or better			
Graphics card w/hardware accelerator			
DVD-ROM drive			
Microsoft compatible pointing devices(e.g., mouse, trackball, etc.)			

*Download the NanoScan Acquisition and Analysis Software Manual for a complete description of all Software Features

Professional Version Automation Interface

For customer who want to incorporate the NanoScan 2s into an automated procedure or to create a customized user interface, the PRO version scanheads include an ActiveX Automation Server that can be used by an Automation Client written in Visual Basic for Applications

(VBA), C/C++ or by an application which supports ActiveX Automation, such as Microsoft Excel, Microsoft Word or National Instruments' LabVIEW. The software package include example of programs written in Excel and LabVIEW in the automation folder.

Specifications

Model	Si/3.5/1.8µm	Si/9/5µm	Ge/3.5/1.8µm	Ge/9/5µm	Pyro/9/5µm
Wavelengths	190-1100nm ⁽¹⁾	190-1100nm ⁽¹⁾	700-1800nm	700-1800nm	190-100µm
Slit size	1.8µm	5µm	1.8µm	5µm	5µm
Aperture size	3.5mm	9mm	3.5mm	9mm	9mm
1/e ² Beam diameter range	7µm--3mm	20µm--6mm	7µm--2.3mm	20µm--6mm	20µm--6mm
Spatial sampling resolution	5.3nm-18.3µm				
Scan frequency	1.25, 2.5, 5, 10, 20Hz				
Power reading	User calibrated				
Power aperture window	Metalized Quartz (200mW upper limit)				N/A
Laser type	CW or Pulsed				
Operating range	See Operating Space Charts				
Damage threshold	See Operating Space Charts				
Rotation mount	Standard				
Bus interface	USB 2.0				
OS supported	Windows 7 (64) and Windows 10				
Signal digitization	16bit				
Maximum digitization clock	21.4MHz				
Maximum update rate	20Hz				
Data transfer	Bulk Transfer Mode				
On-board memory	64MB mDDR SDRAM				
Weight	434g (15.3 ounces)				
Operating temperature	0-50°C				
Humidity	90%, non-condensing				
Scanhead dimensions	76.8mm L x 63.5mm Ø				
Power	USB 2.0 Bus Powered				
CPU clock	300MHz				
Memory clock	264MHz				
Scanning motor	Brushed DC, 4W max				
Compliance	CE, UKCA, China RoHS				

Note: (1) Between 950nm and 1100nm, there might be a degradation of system performance

Ordering Information

Supported software	NanoScan Professional ⁽¹⁾		NanoScan Standard	
Model	Item	P/N	Item	P/N
Si/3.5/1.8µm	NS2s-Si/3.5/1.8-PRO	PH00464	NS2s-SI/3.5/1.8-STD	PH00456
Si/9/5µm	NS2s-Si/9/5-PRO	PH00465	NS2s-SI/9/5-STD	PH00457
Ge/3.5/1.8µm	NS2s-Ge/3.5/1.8-PRO	PH00467	NS2s-Ge/3.5/1.8-STD	PH00459
Ge/9/5µm	NS2s-Ge/9/5-PRO	PH00468	NS2s-Ge/9/5-STD	PH00460
Pyro/9/5µm	NS2s-Pyro/9/5-PRO	PH00470	NS2s-Pyro/9/5-STD	PH00462

Software upgrades

NSv2 STD to NSv2 PRO Upgrade	Upgrade NanoScan v2 Standard version software to the PRO version. This upgrade opens the NanoScan automation feature for those users wanting to integrate or develop their own interface using Visual Basic for Applications to embed into such applications as LabView. Return scanhead to factory	PH00417
------------------------------	---	---------

Note: (1) Software includes ActiveX automation feature

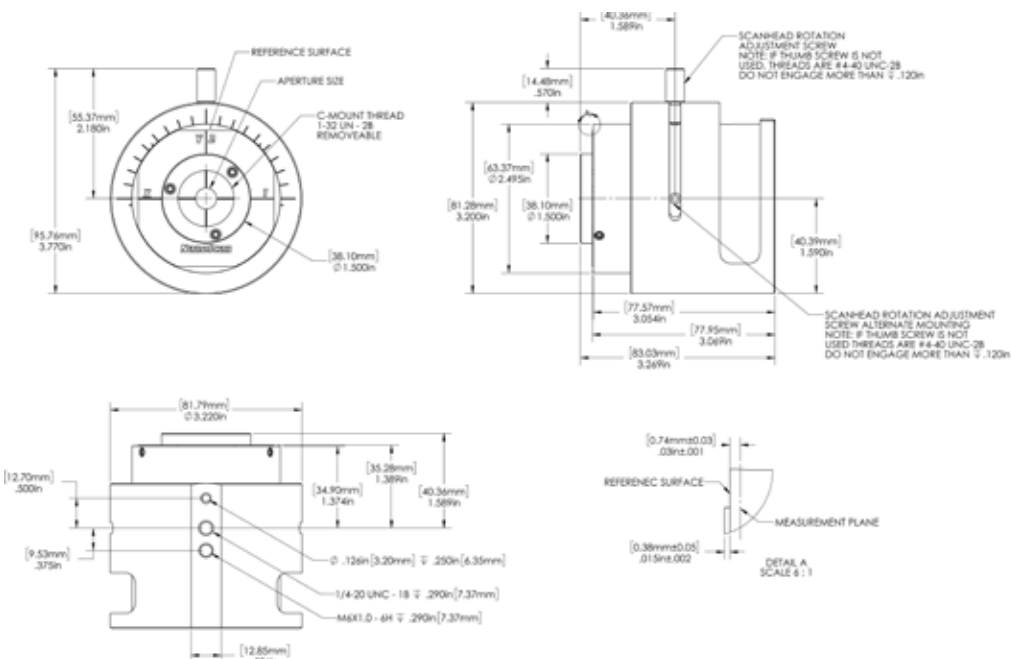

Typical NanoScan Operating Space Charts

Operating range is at peak sensitivity of detector.

Operating space is NOT absolute.

THESE CHARTS TO BE USED AS A GUIDE ONLY.

NanoScan Operating Space
Si/3.5mm/1.8 μ m

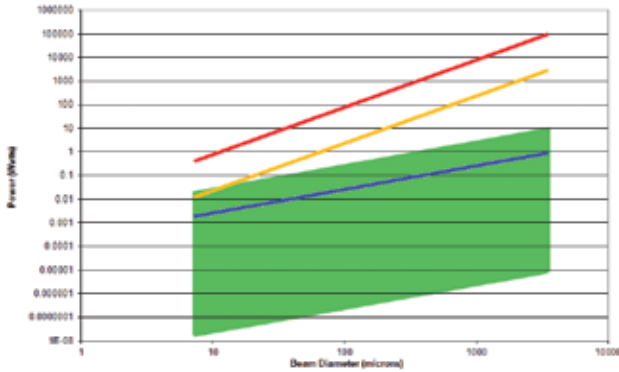

Silicon Detector: Responsivity varies with wavelength. Detects between 400-1100nm. Peak responsivity is 0.7 amps/watt at 980nm. Detector to detector responsivity variation can be as great as $\pm 20\%$.

NanoScan Operating Space
Ge/3.5mm/1.8 μ m

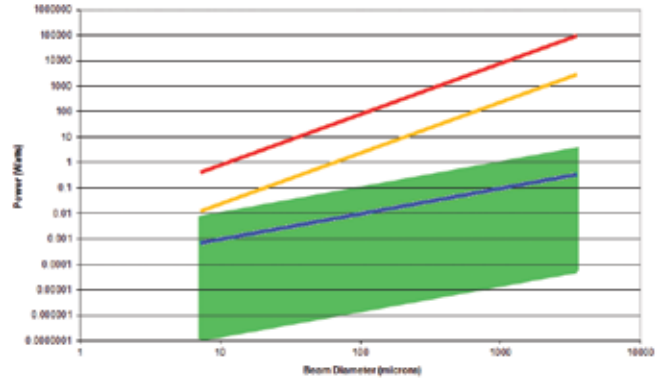

Germanium Detector: Responsivity varies with wavelength. Detects between 800-1800nm. Peak responsivity is 1.05 amps/watt at 1550nm. Detector to detector responsivity variation can be as great as $\pm 20\%$.

NanoScan Operating Space
Pyro/9mm/5 μ m

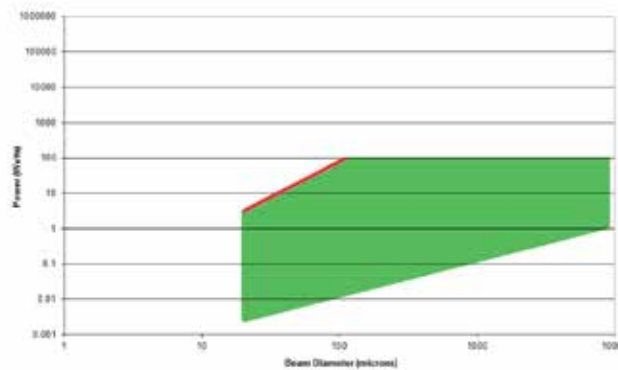

Pyroelectric Detector: Uniform in response between 0.2 and 20 microns wavelength.

Power: Average power in the laser beam.

Beam Diameter: Assumes a round beam. The operating point for an elliptic beam can be approximated by using the average diameter. For extremely elliptic beams (ratio $>4:1$), contact Spiricon.

Pulsed Operation (———): Upper limit of the operating space for pulsed laser measurements.

Black Coating Removed (———): Slits are blackened to reduce back reflections; blackening begins to vaporize near this line. Slits in pyro detectors are not blackened.

Slit Damage (———): Power density (watts/cm²) where one can begin to ablate and cut the slits. Refer to Spiricon's Damage Threshold with *High Power Laser Measurements* document.

Left Boundary: The left boundary is 4 times the slit width, where slit convolution error becomes significant to the 5% level for reported $1/e^2$ diameter of a TEM₀₀ Gaussian beam.

Right Boundary: The right boundary is the instrument entrance aperture diameter, which determines the largest beam profile and diameter that can be measured. For a TEM₀₀ Gaussian beam the $1/e^2$ diameter needs to be $\leq 1/2$ the aperture diameter to measure and see the entire profile out to the tails. Similarly for a Flat-top distribution the $1/e^2$ diameter needs to be $\sim 95\%$ of the aperture diameter. To obtain any given clip level diameter for any beam (but not the full profile) $\sim 95\%$ of the aperture is useable.

3.5 Accessories for Beam Profiling

Introduction

Spiricon has the most extensive array of accessories for beam profiling existing. There are components for attenuating, filtering, beam splitting, magnifying, reducing and wavelength conversion. There are components for wavelengths from the

deep UV to CO₂ wavelengths. Most of the components are modular so they can be mixed and matched with each other to solve almost any beam profiling requirement needed.

3.5.1 Neutral Density Attenuators/Filters

For almost all applications, the laser beam intensity is too high for the operating range of the CCD. Therefore ND glass attenuator filters are available to reduce the intensity to the proper level at the CCD. These filters are carefully designed

not to affect beam quality or cause interference effects. One stackable ND1 filter and 2 ND2 filters are supplied standard with each c-mount camera.



Model	Stackable ND Filters ND1 / ND2 / ND3	ATP-K Variable Attenuator	UV ND Filters	Specialty Filter for 355nm
Nominal ND value	1, 2, 3	ND=1.7-4.6 Max. ND: 7.4 (with fixed 2.8 gray-glass attenuator)	0.3, 0.7, 1.0, 1.3, 1.7, 2.0, 2.3, 2.7, 3.0, 3.3, 3.7, 4.0, 4.3, 4.7, 5.0, 6.0	Pass 355nm, blocks 532nm & 1064nm
Clear aperture	Ø19mm	Ø15mm	Ø20mm	Ø19mm
Damage threshold	~50W/cm ² / 1J/cm ² for ns pulses no distortion	100mW/mm no thermal lensing	100W/cm ² CW, 10ns pulses, no distortion	5W/cm ² no distortion
Mounting	C-Mount Threads	C-Mount Threads	C-Mount Threads	C-Mount Threads

Stackable ND filters

The individual filters come in three versions, the ND1 filter in the red housing with ~10% transmission in the visible, the ND2 filter in the black housing with ~1% transmission and the ND3 filter in the green housing with ~0.1% transmission. The individual filters can be screwed on top of each other and thus stacked and also can be combined with beam splitters. They are set at a small wedge angle in the housing so as not to cause interference effects.



Transmission vs. Wavelength

These bulk-absorbing "neutral density" or ND filters do not have a flat response in attenuation vs. wavelength. See the graph for typical transmission vs. wavelength characteristics.

Specifications

Model	ND1 Stackable Filter (Red housing)	ND2 Stackable Filter (Black housing)	ND3 Stackable Filter (Green housing)
Nominal ND (vis)	1	2	3
Transmission ⁽¹⁾	between 20% and 5%	between 7% and 0.5%	between 2% and 0.05%
Clear Aperture	Ø19mm		
Damage threshold	~50W/cm ² / 1J/cm ² for ns pulses		
Part number	SPZ08234 ⁽²⁾	SPZ08235 ⁽³⁾	SPZ08253

Notes: (1) Depending on spectral range.
 (2) One ND1 filter is included in Ophir cameras.
 (3) Two ND2 filters are included in Ophir cameras.

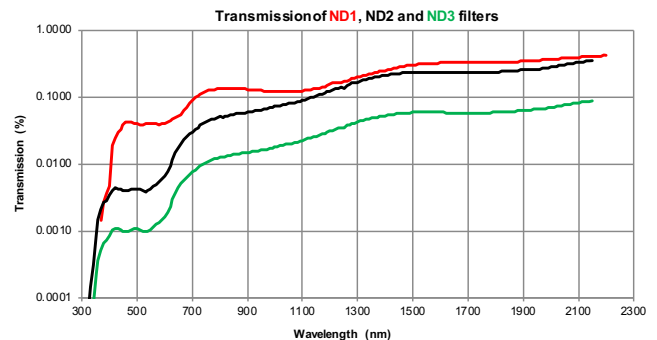

ATP-K Variable Attenuator

This option makes beam profiling easy. The ATP-K attenuates your laser without ghost reflections, fringes and light leaks. A knob-operated variable wedges attenuation of ND 1.7-4.6 with fixed gray-glass attenuator with ND 2.8, provides total attenuation capability of ND 7.4.

The ATP-K is also designed to be used with the HP-series, high power attenuators and beam splitters. Both types of attenuators attach directly to the ATP-K via C-mount while a Beam profiler camera is attached from the opposite side. The ATP-K has simple reproducible attenuation settings, and has a wavelength range of 360 to 2500+ nm.

Figure 1 on the right shows the safe average power for negligible beam distortion from thermal lensing. Absorptive filters, such as used in the ATP-K have an upper power limit of approximately 100mW per mm beam diameter. For pulsed beams, Figure 2 shows the damage threshold for energy where breakage of the glass wedge may occur. This is approximately 5J per mm beam diameter. For lasers with power or energy levels above this the first stage of attenuation will need to come from our line of high power reflective attenuators.

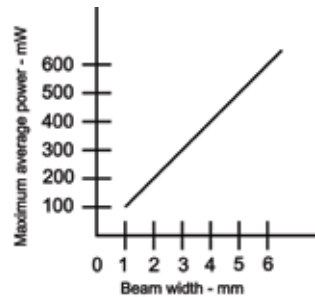

Figure 1 – Safe average power for negligible beam distortion

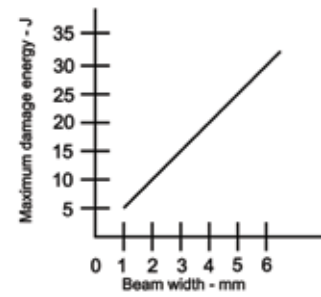

Figure 2 – Point at which damage will occur with pulsed energy

Specifications

Model	ATP-K
Maximum Power/Energy Handling ⁽¹⁾	100 mW/mm, 100 mJ total avg. Energy Damage threshold: 5J
Wavelength Range	360-2500+ nm Near flat response out to 1500nm
Attenuation Range ⁽²⁾	Variable filters: ND = 1.7 to 4.6 Maximum ND 7.4 (with fixed 2.8 gray-glass attenuator)
Clear Aperture	15mm diameter
Dimensions	94 (W) x 28 (H) x 43 (D) mm
Thickness Tolerance	±0.25mm
Mounting	C-mount
Base Mount	1/4-20
Part number	PH00128

Notes: (1) Powerful laser sources may require additional attenuation prior to the beam's exposure to Model ATP-K. Additional attenuation usually is achieved by use of high-power laser mirror attenuators or clean, high-quality quartz plates (recommended with slight wedge angles).

(2) ND (optical density) = $\log(1/T)$ or $T=10^{-ND}$ where T is the fraction of light transmitted. For example, an ND of 5 transmits 0.00001 or 0.001%.

ATP-K

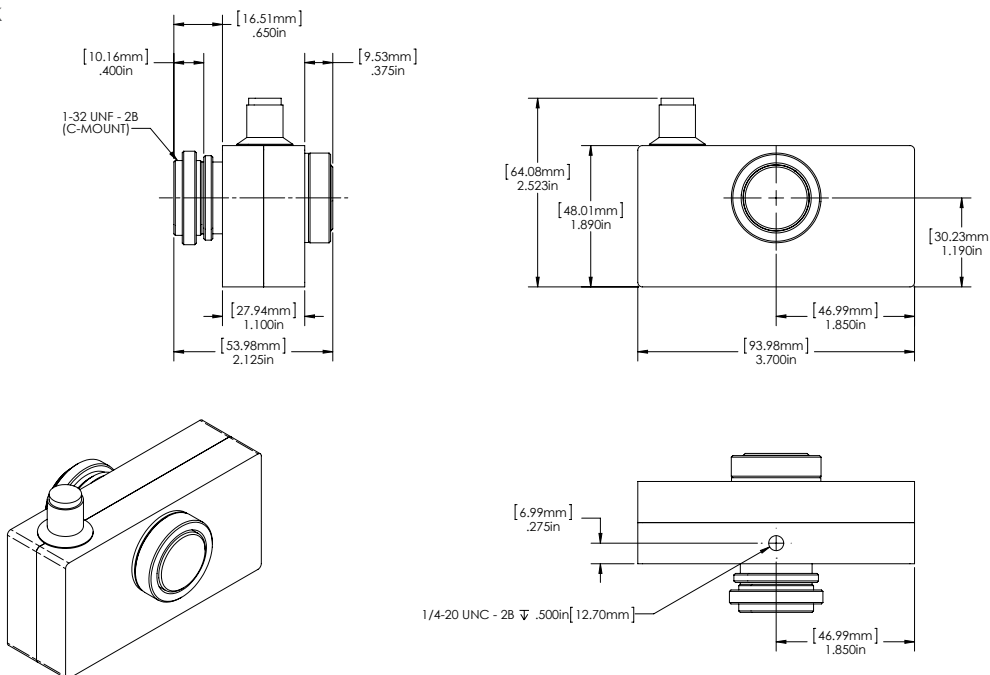

UV ND Filters

This accessory can be used with any camera fitted with C-mount threads. Simply thread the attenuator assembly into the front of the camera and then slide the ND filter arrays to get the desired amount of attenuation. This device can be used with laser outputs from microwatts to Watts. Three filter holders are provided with two filters in each holder. Each filter in the holder provides for a different value of attenuation. To use, slide the desired holder into the housing slot. A click is felt when the filter is properly aligned with the beam. The holders provided will allow for attenuation of up to ND 6. C-mount interface for universal application to our CCD and Pyroelectric cameras 190-380nm attenuation covers Excimer, Helium Cadmium, and the Nd:YAG UV harmonic laser wavelengths. Attenuation with these ND filters permits the best use of the dynamic range of a beam profiling camera. Attenuation range of 0.3 to 6.0 optical densities (ND) Set consists of three slides with two filters in each slide The Six Filters include 0.3, 0.7, 1.0, 2.0, 3.0 and 4.0 optical densities

Two filters can be employed at one time for 0.3 – 6.0 optical attenuation in 0.3 or 0.4 ND steps

20mm clear aperture will not vignette any of our applicable camera sensors

Damage threshold = 100W/cm² for CW lasers and 20mJ/cm² for nano-second pulse width lasers

Additional Beam Splitters can be added for attenuation of high power UV lasers

UV attenuation system uses high quality optics from the leader in laser beam diagnostics

UV ND Filters



Filter ND value vs. Wavelength UV Range

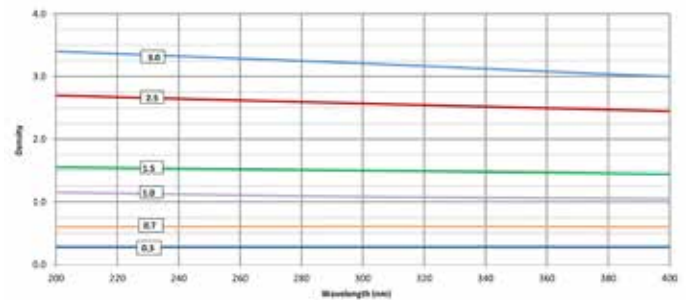

Specifications

Model	UV ND Filters
Nominal ND (UV)	0.3, 0.7, 1.0, 1.3, 1.7, 2.0, 2.3, 2.7, 3.0, 3.3, 3.7, 4.0, 4.3, 4.7, 5.0, 6.0
Aperture	Ø20mm
Damage threshold	100W/cm ² CW, 20mJ/cm ² , 10ns pulses
Filter material	Inconel
Part number	SP90228

Specialized Filters

There are also specialized filters available to eliminate extraneous wavelengths when measuring very short or very long wavelengths where the CCD cameras are not sensitive and the desired signal can get swamped by extraneous light of other wavelengths.

The filter 355nm for monitoring the 3rd harmonic of YAG, transmits 355nm but blocks 532nm and 1064nm

Filter for 355nm



Specifications

Model	Filter for 355nm
Transmission	~ 60 at 355nm, zero at 532nm, and 5E-6 at 1064nm
Filter Thickness	4mm
Filter Spacing	8mm
Flatness	2 waves in the visible
Damage threshold	50W/cm ² / 0.6J/cm ²
Part number	SPZ08246

This filter has the same standard thread so it can be mixed with all the other components.

3.5.2 Beam Splitter + Neutral Density Filters Combo

The attenuators described before can provide a high degree of attenuation however, these neutral density attenuators cannot dissipate more than 5W or so. Therefore we often place beam splitters in front of the attenuators to reduce the intensity before the ND filters.

These beam splitters are made of UV grade fused silica for use from 190 to 2500nm. Since they do not absorb light, they have a much higher power handling capacity than the ND attenuator/filters.



Model	LBS-300s	LBS-300HP-NIR	LBS-400	LBS-100
Wavelengths	multiple versions from 190-2500nm	980-1100nm	UV or 10.6µm	multiple versions; 400-700nm, 1064nm, 10.6µm
Reflection	0.01% of incident beam For reflectance Spectra see LBS-300 User Note	<0.0001%	0.01%	4% @ 400-900nm, 1% @1064nm, 0.5% or 5% @10.6µm
Nominal ND value	See spec sheet	0.4, 0.8, 1, 2, 3, 4	0.5, 1.0 in both filters	0.3, 0.7, 1, 2, 3, 4 for 300-700nm & 1064nm 30% & 60% for 10.6µm
Clear Aperture	Ø17.5mm	Ø15mm	Ø31.75mm	Ø19mm
Damage threshold	See spec sheet	See spec sheet	See spec sheet	See spec sheet
Mounting	C-Mount	C-Mount	Custom thread	C-Mount and Lab post mounted

LBS-300s Beam Splitters

The LBS-300s beam splitter attachment for C-mount, CS-mount, or Ophir mount cameras allow you to measure laser beams with diameters up to 15mm and powers ranging from 10mW to ~400W ⁽¹⁾. The beam sampler is designed so that the preferential polarization selection effect of a single wedge is cancelled out and the resulting beam image is polarization corrected to restore the polarization components of the original beam. The beam sampler operates by reflecting the incoming beam from the front surfaces of a pair of wedges through 90 degrees into the camera. Approximately 99% of the beam is transmitted through the beam sampler with 0.01% passed on to the camera. A set of adjustable ND filters are provided to make final intensity adjustments to the beam before it reaches the camera imager. If additional attenuation is needed, an external wedge may be mounted at the input port, however this 3rd wedge will cause polarization selectivity when the beam is significantly polarized different in the S and P planes. A 1.035-40 thread is provided behind each wedge along the axis of the output beam that can be used to directly mount accessories with 1" lens tubes such as beam dumps or even power and energy sensors to the LBS-300s.

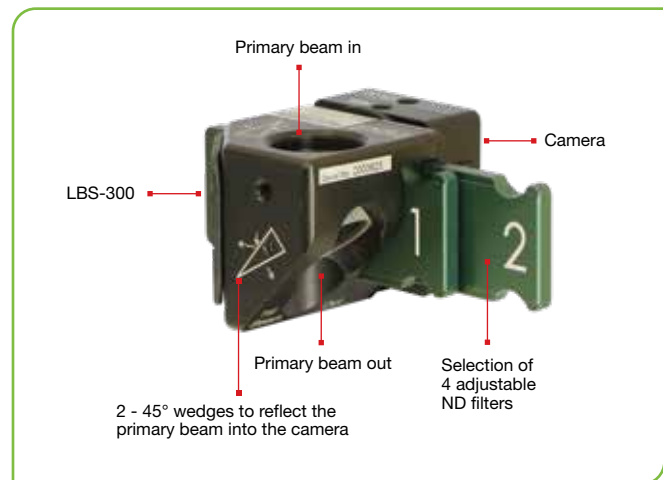

(1) For Gaussian beam diameter <1/2 the clear aperture and depending on ND filter and camera saturation limits the maximum power may be as high as 1000W.

Specifications

Model	LBS-300s-UV	LBS-300s-VIS	LBS-300s-NIR	LBS-300s-BB
Wavelengths	266-355nm	400-950nm	950-1800nm	190-2000nm
Wedge Material	UVFS	UVFS	UVFS	UVFS
Wedge Coating	A/R ≤1%	AR ≤1%	AR ≤1%	No coating, 4% reflection
Clear aperture	17.5mm	17.5mm	17.5mm	17.5mm
Reflection ⁽¹⁾	0.01%	0.01%	0.01% ⁽²⁾	0.16%
Wedge ND value, each	ND ≥2	ND ≥2	ND ≥2	ND ~1.3
Maximum allowable input to wedge	1MW/cm ² 5 J/cm ²	1MW/cm ² 5 J/cm ²	1MW/cm ² 5 J/cm ²	10MW/cm ² 20 J/cm ²
ND Filters	Inconel	Bulk ND	Bulk ND	Combination of Inconel and Bulk ND
ND Values, nominal	0.3, 0.7, 1.0, 1.5, 2.0, 3.0 (Blue holders)	0.3, 0.7, 1.0, 2.0, 3.0, 4.0 (Green holders)	0.4, 0.8, 1.0, 2.0, 3.0, 4.0 (Red holders)	See Broad Band (BB) chart below
Filter Slides	3	3	3	5
Maximum allowable input to filter ⁽³⁾	100 W/cm ² CW 20mJ/cm ² , 10ns pulse	50 W/cm ² 1J/cm ² , 10ns pulse	50 W/cm ² 1J/cm ² , 10ns pulse	See UV, VIS and NIR specifications
Part number	SP90464	SP90465	SP90466	SP90467

Accessories

Large C-mount Wedge Splitter	For additional attenuation add this to the front end of the LBS-300. Good for 350-2000nm	SP90273
Beam Deflector Assembly	for 350-1200 nm only	SP90263
Beam Deflector Assembly	For 266 nm, high damage threshold	SP90287
Beam Deflector Assembly	For 355 nm, high damage threshold	SP90286
Beam Deflector Assembly	For 532 nm, high damage threshold	SP90285
Beam Deflector Assembly	For 1064 nm, high damage threshold	SP90284
2" LT- Mount Extension Tube	2" Extension tube between LBS-300s and camera, reduces noise on the camera, reduces intensity on ND, other uses	SP90575
3" LT- Mount Extension Tube	3" Extension tube between LBS-300s and camera, reduces noise on the camera, reduces intensity on ND, other uses	SP90574
LT To External C-Mount Adapter	Adapter to fit tube to LBS-300s - required with 2" and 3" extension tubes	SP90576
LT To Internal C-Mount Adapter	Adapter to fit tube to camera mount - required with 2" and 3" extension tubes	SP90577

Notes: (1) For reflectance Spectra see LBS-300 User Note.
 (2) For 1000nm reflectance is ~0.04% and for 950nm reflectance is ~0.16%.
 (3) This is the damage threshold of the filter glass of the filters. Distortion of the beam may occur with average power densities of 5W/cm² for beam size 5mm, 10W/cm² for 2mm beam and >30W/cm² for 1mm beam

Optional SP90273 Large C-mount Wedge Splitter

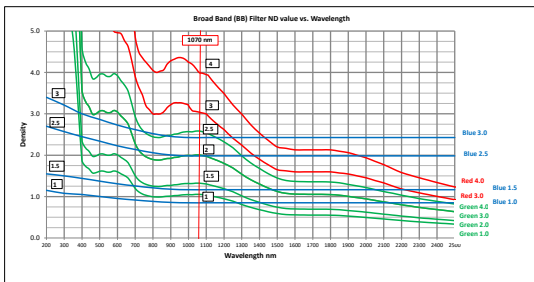

VIS and NIR ND glass filter set (Green and Red Holders) & UV metallic coating filter set (Blue) - SP90467

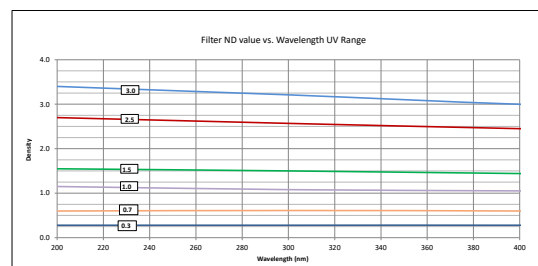

UV filter set (Blue Holders) – SP90464

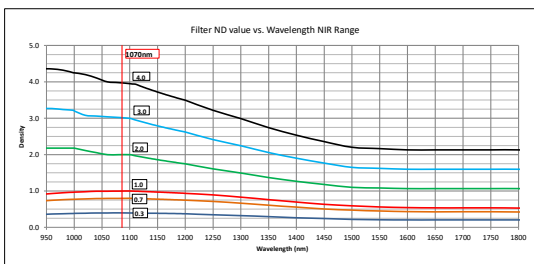

NIR filter set (Red Holders) – SP90466

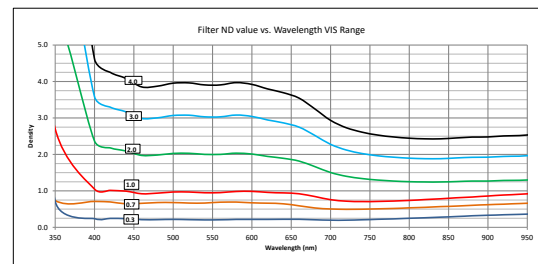

VIS filter set (Green Holder) – SP90465

Beam Extending Negative Lenses for LBS-300s

Sometimes we want to measure the focal spot of converging beam but the focal length of the system is not enough for the beam to go through the LBS and reach the camera focal plane.

Also, sometimes the focal spot is too small for the pixel spacing of the camera. The above problem can be solved by simply screwing a negative lens on top of the LBS and thus extending the focal spot as shown in the diagram.



Model	FSA-50Y	FSA-100Y	FSA-150Y
Negative lens focal length	~50mm	~100mm	~150mm
Use with original focal length	35-99mm	100-149mm	150-mm
Approx. image magnification	2.8	1.9	1.5
Part number	SP90187	SP90188	SP90190

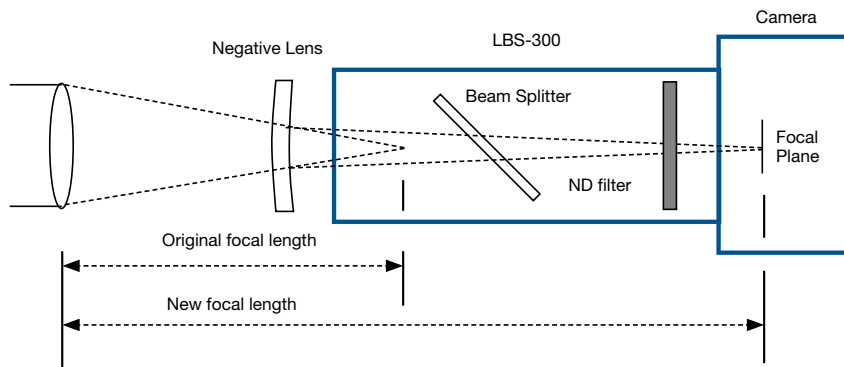

LBS-300HP-NIR Beam Splitters

Beam Splitter for High Power Lasers NIR

The LBS-300HP-NIR is a patent pending technology beam splitter for High Power lasers that allows measuring NIR (~1064nm) focused or collimated laser beam profiles up to 5kW or 15MW/cm².

The LBS-300HP-NIR operates by reflecting a fraction of the incoming beam through the front surface of each of a pair of orthogonally oriented wedges. Less than 0.0001% (1/10⁶) of the beam is reflected towards the Ophir Beam Profiler Camera. This enables beam shape, focal spot, beam waist, M² of a high-power laser; up to 5kW or 15MW/cm².

Relative power can be measured by placing an Ophir power sensor after the first wedge, thereby measuring the laser beam after being reduced to 0.1% (1/10³).

99.9% of the laser beam passes through, ideal for absolute power measurement .

Each optical path through the LBS-300HP-NIR provides uniform attenuation of any beam shape (Gaussian, flat-top, doughnut, etc.) while preserving the polarization and overall profile of the incoming laser beam thus providing accurate sample of incident beam. A 1.035-40 thread is provided behind each wedge along the axis of the output beam.

These can be used to directly mount accessories with 1" lens tubes such as beam dumps or power/energy sensors.

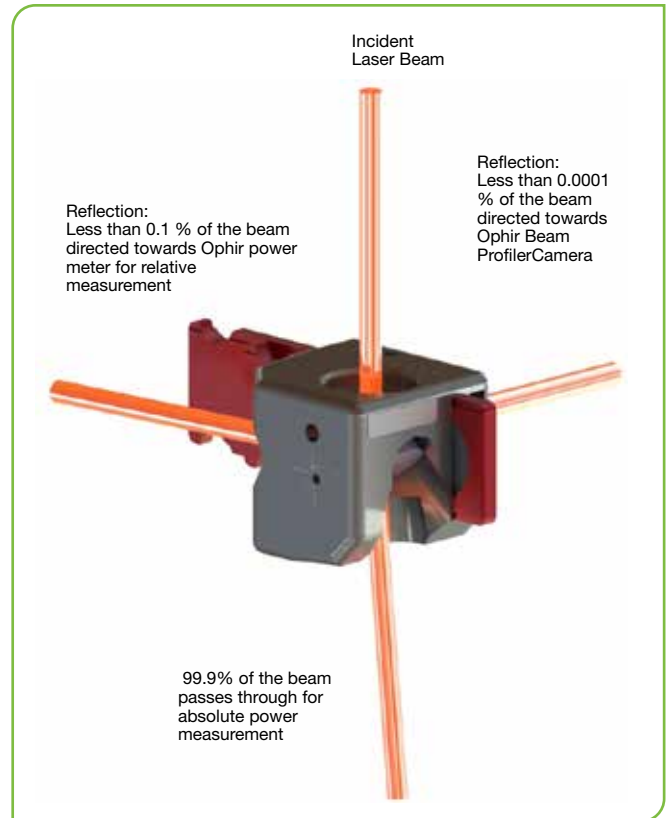

Specifications

Model	LBS-300HP-NIR
Wavelengths ⁽¹⁾	1000-1100nm
Wedge Material	UVFS
Wedge Reflection (each)	<0.1%
Surface Quality	λ/6
Clear Aperture	15mm
LBS-300HP-NIR Reflection	0.000025% - 0.0001% (1/10 ⁶)
Wedge ND value	≥3
Maximum Laser Power Exposure	5 kW for up to 10 minutes
Minimum Detectable Laser Power	100 mW
Maximum Power Density ⁽²⁾ , Energy Density	15MW/cm ² , 10J/cm ² at beam splitter
3 x Bulk Filters ND ⁽³⁾ values, nominal	0.4, 0.8, 1.0, 2.0, 3.0, 4.0 (Red Holders)
Part number	SP90540

Suggested Add-Ons

Item	Description	P/N
SP932U	Beam Profiler CMOS-based cameras	SP90606
SP920s	Beam Profiler CCD-based cameras	SP90549
Ge/9/5µm	Slit Based Beam Profilers, NanoScan 2s	PH00460
BD10K-W-V1 Beam Dump	Beam Dumps Up to 11kW Max Power, Water Cooled	7Z17205
Power Sensors	Compatible with most Ophir sensors	See catalog pages 79-89

Notes: (1) Although the LBS-300HP-NIR is designated for 1000nm -1100nm, the real spectral range is significantly wider and covers 500nm-1500nm range. However, the spec above refers only to designated wavelength and can't be guaranteed for out of the range wavelength. Red alignment laser can also be used with LBS-300HP-NIR for alignment and targeting.
 (2) 15 MW/cm² was maximal power density that was tested. Actual Maximum Power Density may be higher.
 (3) ND bulk absorbing filters damage threshold is 5W/cm² for beam size 5mm, 10W/cm² for 2mm beam and >30W/cm² for 1mm beam.

LBS-300HP-NIR

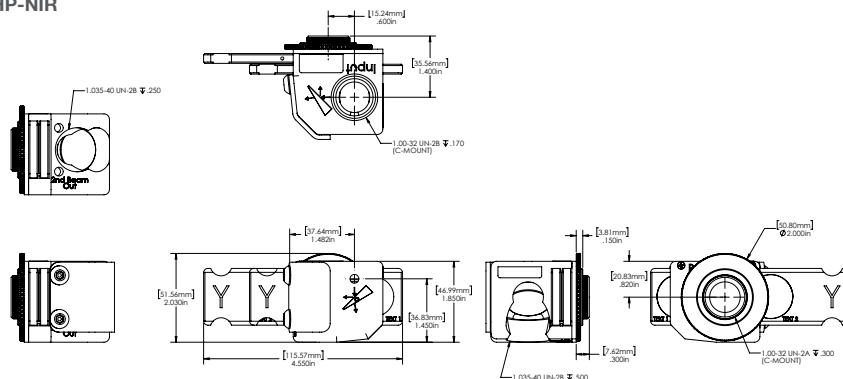

LBS-400 Beam Splitters

The LBS-400 beam sampler attachment for various large array cameras allow you to measure UV, NIR or IR wavelength laser beams with diameters up to 1 inch (25.4mm) and powers ranging from 10mW to ~500W⁽¹⁾. The beam sampler is designed so that the preferential polarization selection effect of a single wedge is cancelled out and the resulting beam image is polarization corrected to restore the polarization components of the original beam.

The beam sampler operates by reflecting the incoming beam from the front surfaces of a pair of wedges through 90 degrees into the camera. Approximately 99% of the beam is transmitted through each beam sampler with 0.01% passed on to the camera. A set of adjustable filters are provided to make final intensity adjustments to the beam before it reaches the camera imager.

LBS- 400



(1) For Gaussian beam diameter <1/2 the clear aperture and depending on ND filter and camera saturation limits the maximum power may be as high as 1200W.

Specifications

Model	LBS-400-UV	LBS-400-NIR	LBS-400-IR
Wavelengths	193-355nm	900-1800nm	10.6µm
Wedge Material	UVFS	BK7	ZnSe
Wedge Coating	A/R ≤1.5%	A/R ≤1%	A/R ≤1%
Clear Aperture	1.25 inch (31.75mm)	1.25 inch (31.75mm)	1.25 inch (31.75mm)
Reflection	0.01%	0.01%	0.01%
Wedge ND value (each)	ND ≥2	ND ≥2	ND ≥2
Filter Material	Inconel	Bulk ND	CaF2
Filter ND Values nominal	0.5, 1.0 in both filters	0.5, 1.0 in both filters	0.5, 1.0 in both filters
Adjustable Filter Slides	2	2	2
Filter Damage ⁽¹⁾	100 W/cm ² 20mJ/cm ² , 10ns pulse	50 W/cm ² 1J/cm ² , 10ns pulse	5W/cm ² 300 J/cm ² , 1ms pulse
Part number	SP90351	SP90354	SP90349

Accessories

Every LBS-400 comes with a user specified adaptor plate. Please choose at time of purchase

LBS-400 C-Mount Adapter	Adaptor plate to mount C-Mount devices to LBS-400	SP90352
LBS-400 to SM2 Adapter	Adaptor plate to mount SP504S camera to LBS-400	SP98000
LBS-400 to Pyrocam™ Adapter	Adaptor plate to mount Pyrocam IV camera to LBS-400	SP90510
LBS-400 to WB-I Adapter	Adaptor plate to mount WB-I to LBS-400	SP90572

Note: (1) ND filters should be used at 5W/cm² for beam size 5mm, 10W/cm² for 2mm beam and >30W/cm² for 1mm beam to avoid thermal lensing effects.

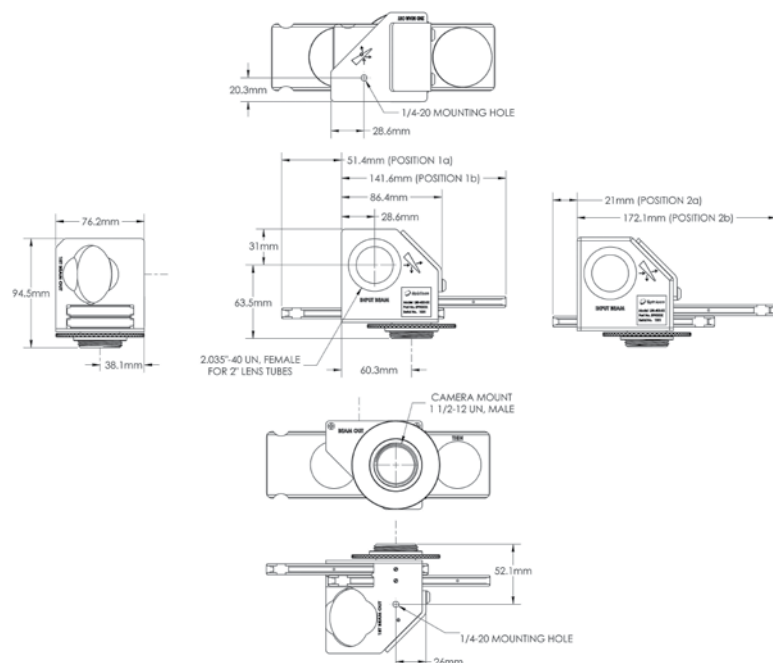

LBS-400 mounted to Pyrocam IV

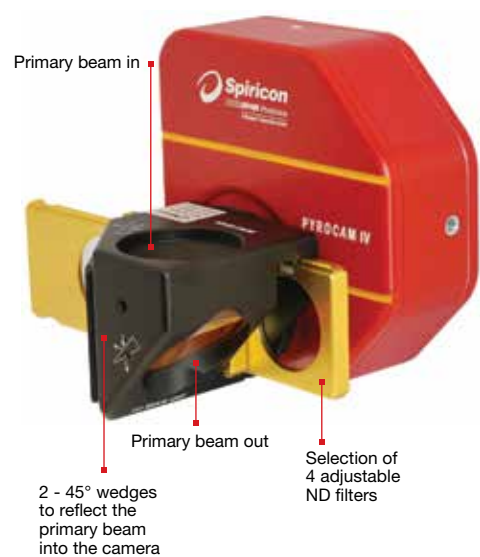

LBS-100 Attenuator

The LBS-100 system that is not as compact as the LBS-300s above but has larger aperture, and has versions for longer wavelengths. The system contains the mounting frame, 1 wedge beam splitter and several attenuators. The exit end of the LBS-100 is standard C mount thread so all our cameras can be mounted to the frame. The wedge angle is 6.5 degrees to insure that the reflection from the rear side will not enter the camera. The optical elements are flat to 1/4 wave in the visible to ensure no distortion of the beam.

LBS- 100



Specifications

Model	LBS-100	LBS-100 YAG	LBS-100 IR 0.5	LBS-100 IR 5.0
Wavelengths	400 - 700nm recommended, functional to 2600nm	1064nm	10.6µm	10.6µm
Wedge Material	UVFS	UVFS	ZnSe	ZnSe
Wedge Coating	No coating, 4% reflection	A/R ≤1%	A/R ≤0.5%	A/R ≤5%
Clear Aperture	19mm	19mm	19mm	19mm
Filter Material	Bulk ND	Bulk ND	CaF2	CaF2
Filter ND Values/ Transmission	0.3, 0.7, 1.0, 2.0, 3.0, 4.0 ND at 632nm	0.3, 0.7, 1.0, 2.0, 3.0, 4.0 ND at 632nm	30% T for 3mm flat, 60% T for 1mm flat	30% T for 3mm flat, 60% T for 1mm flat
Filter Damage ⁽¹⁾	50W/cm ²	50W/cm ²	50W/cm ²	50W/cm ²
Part number	SP90061	SP90057	SP90058	SP90059
Accessories				
LBS-100 filter set	Replacement filter set			SP90141
LBS-100 –YAG filter set	Replacement filter set			SP90142
LBS-100 to SM2 Adapter	Mount SP504S camera to LBS-100 attenuator			SP98001
LBS-100 to 4X beam reducer adapter	This adapter enables mounting of the LBS-100 beam splitter/attenuator assembly in front of the 4X beam reducer. The combined assembly can image large high power beams in one unit.			SPZ17029

Note: (1) ND filters should be used at 5W/cm² for beam size 5mm, 10W/cm² for 2mm beam and >30W/cm² for 1mm beam to avoid thermal lensing effects.

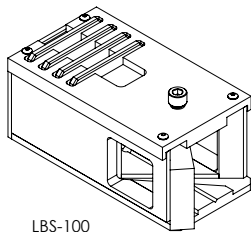

LBS-100

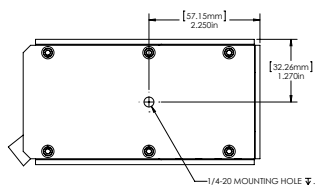
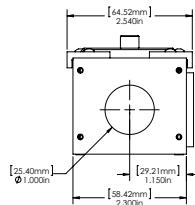
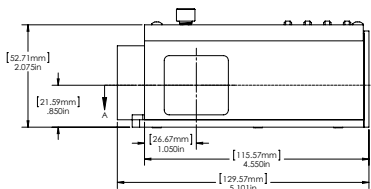
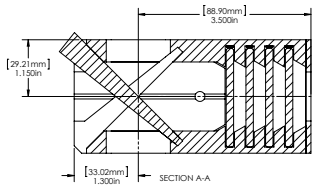

The LBS beam splitter/attenuator system can be combined with the 4X beam reducer, to attenuate and view large beams.



3.5.3 Beam Splitter



Model	Beam Tap I & II	Beam Tap I & II YAG	Stackable Beam Splitter	Single & Dual Front-Surface Beam Samplers
Wavelengths	400-700nm	1064nm	190-2000nm	200nm-2.5µm
Reflection	4% & 0.16% of incident beam	0.5% & 0.0025% of incident beam	5% & 0.25% of incident beam	0.057% @ 532nm
Clear aperture	Ø17.5mm	Ø17.5mm	Ø15mm	14mm x 14mm
Damage threshold	1MW/cm ² CW, or 1MJ/cm ² pulsed	1MW/cm ² CW, or 1MJ/cm ² pulsed	>5J/cm ²	100MW/cm ²
Mounting	C-Mount Threads	C-Mount Threads	C-Mount Threads	C-Mount Threads

Beam Tap I & II

- Dual surface reflector for equalizing S & P polarization
- The two planes of reflection are orthogonal

Single Surface Polarization Problems

A single surface reflection at 45° is often used to sample a laser beam for profile measurements or for monitoring power or energy. However, as shown on page 259, at 45° a single surface reflects the S polarization component at more than 10 times the reflection of the P component. Depending on the laser polarization content, or stability, this sampling can provide very misleading and unreliable measurements. (The BT-I-YAG has both surfaces A/R coated for 1064nm so the reflection for both polarizations is equal at 0.5%. At other wavelengths far from 1064nm the above discussion applies).

Equalizing S & P reflected polarization

Any arbitrary polarization component can be broken into equivalent S & P components. With complimentary sampling surfaces any given component gets reflected once as the S polarization, and the second time as the P polarization. Thus using 2 surfaces, the total reflected energy for all polarization components is the sum of the S reflectance and the P reflectance. This causes the sampled beam to have S & P components that are identical to the original beam.

Beam path through beam tap

The Beam Tap II uses two reflecting surfaces such that the two planes of reflection are orthogonal. The standard Beam Tap I rear surface is AR coated from 400-700nm.

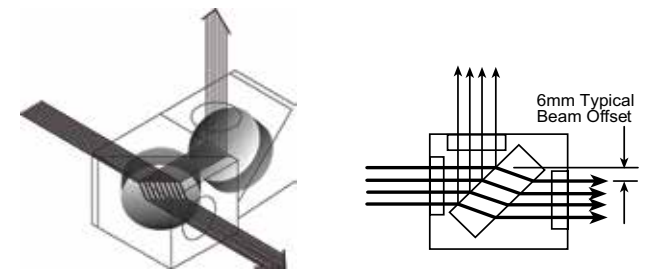

This diagram shows the 6mm offset of the through beam that is created by the reflecting optic. The deflection angle of the output beam is less than 0.007 degrees. The rear surface of the flat is AR coated to maximize the throughput of the main beam. The standard Beam Tap II rear surface is AR coated for 400nm-700nm. The YAG version is AR coated for 1064nm on both surfaces.

Beam tap reflection vs wavelength

Shown is the Beam Tap II final sampled reflection vs. wavelength. As shown both the S & P reflection are nearly constant at 0.05% from the UV to the infrared.

(See figure 7 in the Beam Tap manual in our website)

Specifications

Model	BT-I	BT-II	BT-I-YAG	BT-II-YAG
Wavelengths	400-700nm	400-700nm	1064nm	1064nm
Surface	Single surface, 1 cube	Dual surface, 2 cubes	Single surface, 1 cube	Dual surface, 2 cubes
Optical Material	UVFS	UVFS	BK7	BK7
Reflection	4%	0.16%	0.5%	0.0025%
Damage threshold	1MW/cm ² CW, or 1MJ/cm ² pulsed			
Part number	SP90135	SP90133	SP90173	SP90172

Stackable Beam Splitters

The stackable beam splitters are designed for maximum modularity and shortest beam path. They are compatible with almost all of our cameras having the standard C mount thread and can mount either to other attenuators or to the camera itself. Each beam splitter reflects $\leq 6\%$ of the incoming beam and allows approximately $\geq 94\%$ of the beam to pass directly through. By stacking 2 splitters $\leq 6\%$ or 0.36% of the original beam intensity is directed into the camera. The beam splitters are mounted at 45 degree over the fixed or variable attenuators with a simple fastening ring and can be oriented in any direction with the beam coming from right, left, up, down, or front. The Beam Splitters will operate for wavelengths from 193nm - 2500nm. Damage threshold is $>5\text{J}/\text{cm}^2$ for 10ns pulses.

An optional $\text{Ø}30\text{mm}$ clear aperture splitter allows for larger diameter incoming beams. Caution: Beam convergence and power density must be known at the imager so you don't overflow the imager size and maximum power density at the imager.

A different set of stackable beam splitters are specifically coated for optimization at 1064nm. Each beam splitter reduces the intensity to 1% of the input Beam. 2 stacked splitters will produce a sampling Beam with 0.01% intensity of the original beam.

The wedge angle of 10 degrees insures that only the reflection from the front surface will appear on the camera with no double images. The user must insure that there are beam stops for the transmitted and reflected beams. Note that if possible, the user should use an even number of beam splitters so as to cancel any possible polarization effects.

For converging beams, a larger aperture splitter can be used either by itself or stacked (as shown)



SPZ17015 + SPZ17025



SPZ17015 + SPZ17026
(used either singularly or stacked)

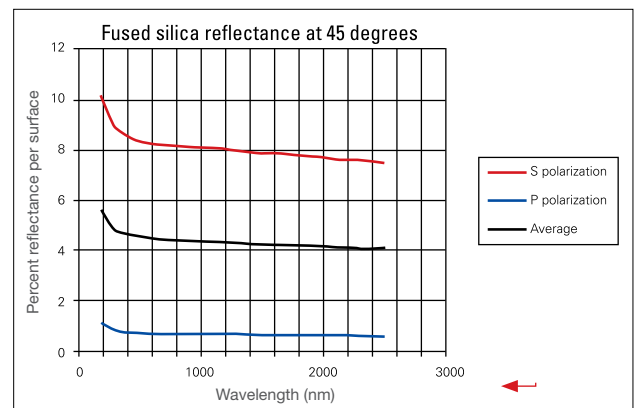

Specifications

Model	1st Wedge Splitter (BB)	2nd Wedge Splitter (BB)	2nd Wedge Splitter, large aperture (BB)	1st Wedge Splitter (NIR)	2nd Wedge Splitter (NIR)
Wavelengths	193 - 2500nm	193 - 2500nm	193 - 2500nm	1064nm	1064nm
Material	UVFS	UVFS	UVFS	UVFS Coated 1064nm	UVFS Coated 1064nm
Clear Aperture	$\text{Ø}15\text{mm}$	$\text{Ø}15\text{mm}$	$\text{Ø}30\text{mm}$	$\text{Ø}15\text{mm}$	$\text{Ø}15\text{mm}$
Reflection	$\leq 6\%$	$\leq 6\%$	$\leq 6\%$	$\leq 1\%$	$\leq 1\%$
Path length to CCD with 3 screw-on ND filters	60mm	93mm	60mm	60mm	93mm
Part number	SPZ17015	SPZ17026	SPZ17025	SPZ17031	SPZ17032

Single and Dual Prism Front-Surface Beam Samplers

The Prism Front-Surface Beam Sampler (PFSA) is a C-mount fixture housing a UV-Grade Fused Silica right angle prism, used for sampling the front surface reflection for high power/energy beam-profiling applications. Reflection at nominal incidence of 45° is polarization and wavelength dependent, with 532nm s-polarization reflected at 8.27%, and p-polarization at 0.68%.

The system is available as either a single prism (PFSA) or dual orthogonal prism (DPFSA) unit. The dual orthogonal prism configuration results in polarization independent reflection of 0.057% at 532nm. Other filters and attenuators can be attached using the C-mount female threads at the input end. The use of a right-angle prism to sample the incident beam guarantees that any scattered secondary beams do not interfere with measurement, as shown in the sketch.

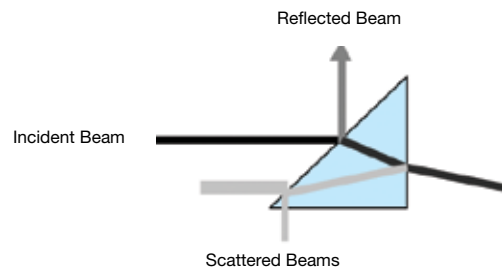

Specifications

Model	PFSA		DPFSA	
Wavelengths	200nm to ~2.5µm		200nm to ~2.5µm	
Optical Material	UV-Grade Fused Silica		UV-Grade Fused Silica	
Prism	Single		Dual	
Surface Quality	20-10		20-10	
Surface Accuracy	λ/10		λ/10	
Angle of Incidence	45°		45°	
Clear Aperture	14mm x 14mm		14mm x 14mm	
Reflection at λ (nm)	P- Polarization	S- Polarization	P- Polarization	S- Polarization
248.3	0.88%	9.40%	0.88%	9.40%
351.1	0.75%	8.65%	0.75%	8.65%
532	0.68%	8.27%	0.68%	8.27%
1064	0.64%	8.01%	0.64%	8.01%
Laser Damage Threshold	CW> 100MW/cm ²		CW> 100MW/cm ²	
Dimensions	38.1mm x 32.3mm x 29.5mm		44.5mm x 40mm x 32.5mm	
Output Mounting with Brass Lock Ring	C-Mount Male (1"-32 Thread Male)		C-Mount Male (1"-32 Thread Male)	
Input Mounting	C-Mount Female (1"-32 Thread Female)		C-Mount Female (1"-32 Thread Female)	
Part number	PH00052		PH00053	

3.5.4 Beam Expanders Microscope Objectives

Model	Beam Expander	4X Beam Expander with UV Converter
Wavelengths	4X : 340-1800nm 6X, 12X, 22X: 530-1100nm	193nm-360nm
Beam Size Change	4X, 6X, 12X, 22X	4X Expansion
Clear aperture	1/4 the size of the CCD imager	
Mounting	C or CS Mount Threads	



Beam Expander

Beam expanders are designed to work with C-mount threaded cameras that have 4.5mm imager back focal spacing or with CS (12.5mm) back focal spacing. The 4X beam expander is an expanding telescope that images the beam as it looks at 8mm from the end of the expander onto the CCD while enlarging the image 4X. In addition to the 4X beam expander, other microscope objectives are available for expanding the beam even more. There are objectives for 6X, 12X, and 22X expansion. The various expanders allow the use of our 2% and 10% filters as well as the variable attenuator so as to accommodate the camera to a wide range of source intensities. With a camera having 4.4µm pixel spacing using the beam expander, the effective resolution can be as good as 0.5µm. The object plane that is imaged onto the CCD is located several mm in front of the assembly so even hard to get to focal spots and other small images are easy to image. The beam expanders are designed to accommodate up to 3 screw on filters or a variable attenuator behind them so a wide range of intensities can be accommodated.

For intensities too large to be accommodated by just filters, beam splitters are available to reduce the intensity before the beam expander. The beam expander is primarily intended for nonparallel beams such as focal spots and fiber tips. If small parallel beams are imaged, interference effects may occur. The 4X Beam expander can also be fitted with a UV converter plate at its object plane so that you can look at small beams in Wavelengths 193-360nm and expand them 4X.



Specifications

Model	4X	6X	12X	22X
Wavelengths	340 - 1800nm	530 - 1100nm	530 - 1100nm	530 - 1100nm
Distance from lens barrel to focus	8mm	16.7mm	10.7mm	3.3mm
Distance from focus to 1st beam splitter	25mm	13mm	12mm	20mm
Distance of closest approach to focus with 2 beam splitter	85mm	73mm	72mm	80mm
Total length of assembly (without beam splitter)	50mm	107mm	101mm	102mm
Total length of assembly (With 2 beam splitter)	122mm	153mm	133mm	133mm
Part number	SPZ17022	SPZ08257	SPZ08259	SPZ08260
Accessories				
Spacer Set	Spacer set for connecting microscope objective 6X/ 12X/ 22X to 4.5mm, CS mount cameras			SPZ08261
Beam Splitter for 4X Expander	45 degree angle wedge beam splitter which mounts onto beam expander. Reduces beam intensity by ~20 times. For spectral range 190 – 2500nm. Introduces 35mm extra beam path to object plane			SPZ17027
Additional beam splitter	Additional beam splitter to mount to 1st beam splitter			SPZ17026

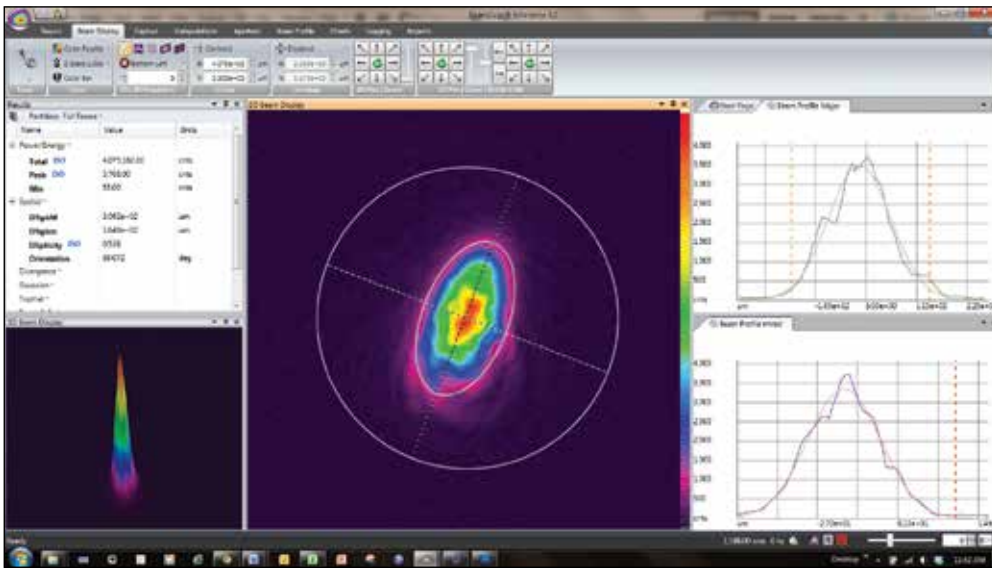

Shown is an image of the tip of a single mode fiber measuring 16 μ m by 30 μ m in the two axes. The beam width as measured on the profiles shows 4X the actual size so we can measure to a resolution of ~2 μ m.



Camera with 4X Beam Expander SPZ17022 and SPZ17027 Beam Splitter



Camera with 4X Beam Expander SPZ17022, SPZ17027 Beam Splitter and SPZ17026 Beam Splitter

4X Beam Expander with UV converter

The UV converter is a UV sensitive fluorescent plate that can be mounted over the 4X Beam Expander. The plate is positioned at the object plane of the 4X beam expander, 8 mm in front of the unit. When UV light at 193-360nm hits the plate, it absorbs the UV and re-emits visible light proportionate to the incident UV light. This light pattern is then expanded 4 times and imaged onto the imaged onto the C-mount camera.



Camera with 4X Beam Expander and UV Image Converter

Specifications

Model	4X Beam Expander with UV converter
Beam Reduction	4X expansion $\pm 2\%$ with included correction factor
Wavelengths	193 - 360nm
Resolution	15 μ m x 15 μ m;
Minimum signal	$\sim 50\mu$ J/cm ²
Saturation intensity	~ 30 mJ/cm ² at 193nm, ~ 15 mJ/cm ² at 248nm 20 times greater with optional beam splitter
Effective Aperture	1/4 the size of the CCD dimensions
Damage threshold	0.1J/cm ² w/o beam splitter, 2J/cm ² w/ beam splitter
Dimensions	$\varnothing 31$ mm dia x 120mm length
Part number	SPZ17022 + SPZ17019

3.5.5 Beam Reducers

4X Reimaging Beam Reducer

The 4X Beam Reducer is an imaging system that images the plane 30cm in front of the reducer onto the camera CCD sensor while reducing the size 4 times and inverting it. The beam reducer uses the 3 screw on attenuators provided with the camera. Since the intensity of a beam after reduction will be increased by $4 \times 4 = 16$ times, it is advisable to attenuate the beam more than you would without beam reduction. This can be done with additional external beam splitters and attenuators which are available (see ordering information). Note that the custom designed beam reducer gives better image quality than tapered fibers since it does not introduce graininess or uneven pixel response. Also the image distortion of $\sim 1\%$ is considerably lower than with most tapered fibers. The beam reducer is not compatible with CS mount cameras.

4X beam reducer



Specifications

Model	4X beam reducer	
Wavelengths	360-1100nm	
Antireflection Coating	Antireflection coating optimized for 1064nm and 532nm	
Beam reduction Accuracy	$\pm 3\%$	
Size	$\varnothing 60$ mm dia x 94mm length	
Aperture	50mm	
Maximum Beam Size	SP932U, SP920s: 28x21.2mm	
Distortion of Beam	Less than 1% over 80% of diameter	
Damage Threshold	30mJ per pulse for nanosecond pulses	
Part number	SPZ17017	
Accessories		
LBS-100 to 4X beam reducer adapter	This adapter enables mounting of the LBS-100 beam splitter / attenuator assembly in front of the 4X beam reducer. The combined assembly can image large high power beams in one unit	SPZ17029
Beam splitter large wedge	Wedge, UVFS, 44X32 mm, uncoated wedge housing mounts to 1/4" thread, 1/2" diameter laboratory rod (not included)	SPZ17018

The 4X beam reducer can be combined with the LBS-100/ LBS- 300s/ LBS- 400 beam splitter/attenuator system to attenuate higher power beams before reducing them in size

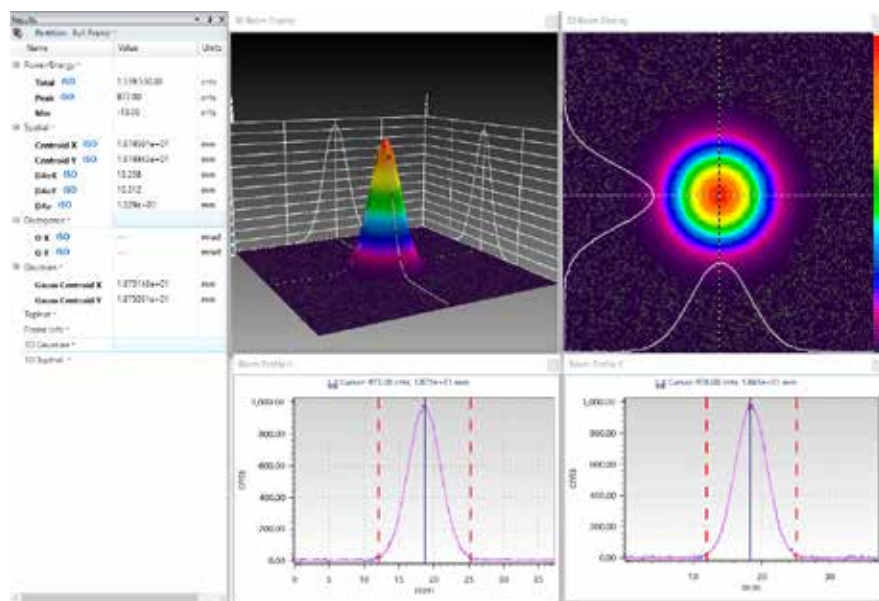

Shown is an image of a laser with beam diameter of 13mm. As can be seen, it is easily seen with the SP920s, SP932U camera with the 4X beam reducer.



Optional large wedge beam splitter (SPZ17018)



LBS-100 (SPZ17029) + LBS-100 combined with 4X beam reducer (SP90061+SPZ17017)

3.5.6 CCTV lens for front imaging through glass or reflected surface

When direct imaging in front of the camera, for example, an image projected onto a diffusing surface, such as a ground glass plate, it is necessary to reduce the image so that it completely fits onto the CCD chip surface. The 25mm and 50mm CCTV lenses image an object from a given plane in front of the lens onto the CCD while reducing the size. The lens can image such objects at distances from about 10cm in front of the lens (20cm for the 50mm lens) to 1 meter or more depending on the distance from the lens to the camera. The distance from lens to camera depends on the camera type and spacers placed between the lens and the camera.

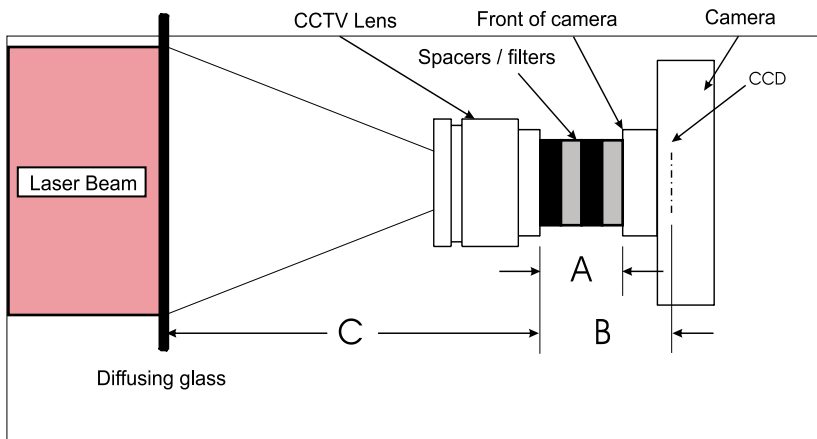
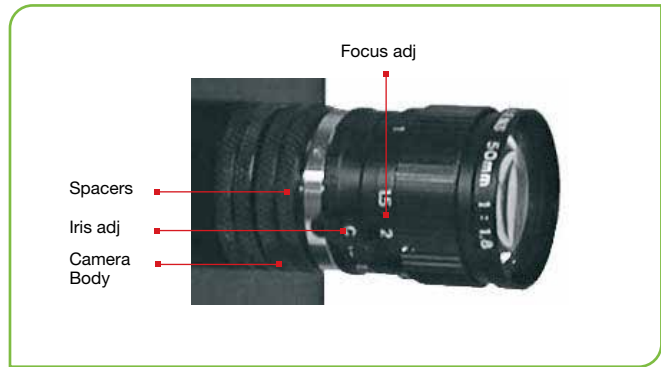

- A** - Total length of spacers added to system
- B** - Detector to Lens spacing. Distance 'A' plus the CCD inset for the camera type
- C** - Lens to Object spacing

CCD inset for Camera Types
 C mount (Camera front to CCD = 17.5mm) for nominal lens magnification, use without spacers.
 CS mount (Camera front to CCD = 12.5mm) for nominal lens magnification, use 5mm spacer.
 SP mount (SP cameras. Camera front to CCD = 4.5mm) for nominal lens magnification, use with 13mm spacers.

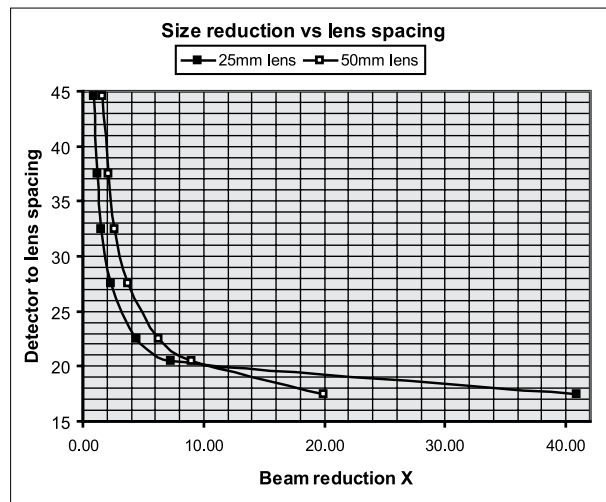
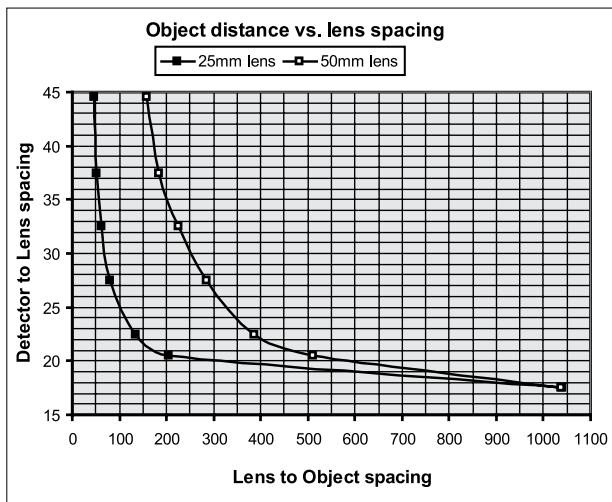

Ordering Information

Item	Description	P/N
25mm focal length CCTV lens kit	25mm focal length lens assembly with locking iris and focus adjustment. Includes 1 ea - 8mm spacer and 2 ea -5mm spacers	SP90085
50mm focal length CCTV lens kit	Same as above except 50mm focal length lens	SP90038
4mm spacer	Screw on spacer to add 4mm spacing to optical system	SPG01698
5mm spacer	Screw on spacer to add 5mm spacing to optical system	SPG02106
8mm spacer	Screw on spacer to add 8mm spacing to optical system	SPG02067

3.5.7 WB-I: Wide Beam Imager

The Ophir Wide Beam Imager: **WB-I** a compact, calibrated accessory for beam profiling cameras, provides a way to measure both size and power distribution of a divergent and large diameter beam coming from sources such as VCSEL, LED as well as parallel beams. It employs a 45mm diffusive plate onto which the beam from the light source is projected. This image is then reduced by 8 times and is reimaged onto the camera focal plane.

VCSELs, LEDs and fiber lasers are used in many sensitive applications. To guarantee the high quality of the devices, it is essential to analyze the beam profile, but those wide, divergent beams place specific requirements on the measurement system:

- The apertures of conventional beam profilers are too small to collect the entire spot of large or divergent light sources.
- Diverging beams cannot be accurately measured with regular detectors because the quantum efficiency of the detector is highly dependent on the angle of incidence.

Compact, ruggedized, and portable design of WB-I enables on-site service of beam profiling of VCSELs and LED systems at the customer site as well as operation at production lines and R&D labs.

- Divergent beams measurement significantly improved due to the possibility of up to 70° angle measurement, compared to 15° of standard beam profiler sensors.
- WB-I accessory, together with the camera and the BeamGage software, provides real-time beam shape analysis and visualization of changes of the beam shape due to different currents can be easily detected.



- Variable attenuation, via set of interchangeable filters or iris enables measuring wide range of light sources of different emitting powers.

Designated for R&D, Production and Service in following fields: Data Telecommunication, Automotive, Remote sensing, Face and gesture recognition

Typical light sources: VCSELs, LED, Wide laser beams, fibers

Typical measurements: Far Field energy distribution, Divergence, LIV sweep test VCSELs (beam profile vs current (A))

The WB-I accessory comes in 2 versions: UV-VIS-NIR (350-1100 nm) or SWIR (900-1700nm) designated for Eye-Safe, IR applications.

The WB-I is purchased without camera. For a complete solution that includes BeamGage Professional imaging and analysis software, high-resolution camera can be added.

Application example: VCSEL energy distribution directly depends on parameters such as current, pulse width and repetition rate and temperature of the device. Therefore, it is essential to measure the angle distribution of VCSELs at various stages of the manufacturing process as well as in R&D and field service. VCSEL behavior on the LIV sweep test: VCSELs are in a so called "LED mode" when there is only a low current applied. Once the current applied to the VCSEL rises, its beam profile changes to "Laser mode":

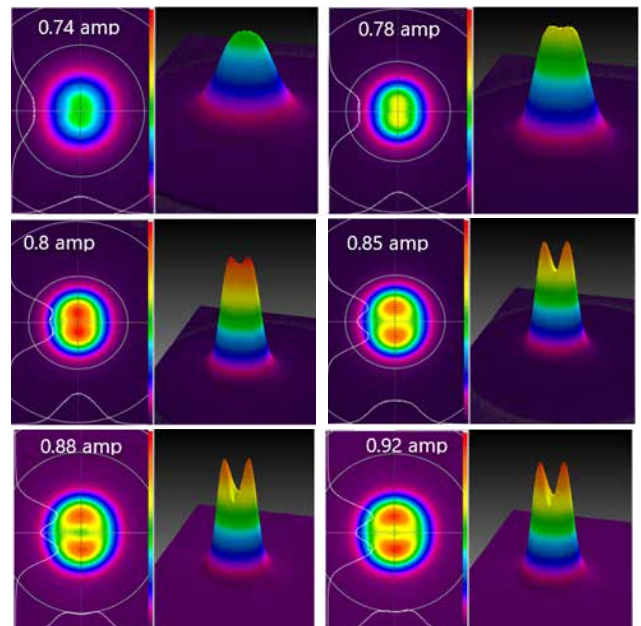
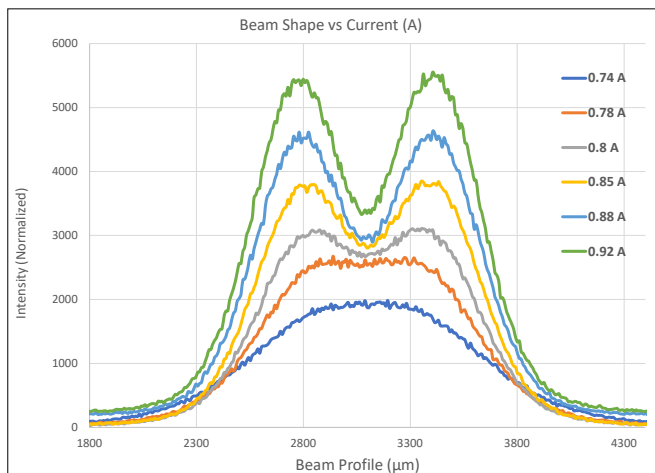

WB-I VIS:

- UV-VIS-NIR (350-1100nm) Wavelengths
- Attenuation by accompanied ND filters (ND1 and ND3) and by variable iris
- Operates with CMOS cameras (purchased separately)

WB-I SWIR:

- SWIR (900-1700nm) Wavelengths
- Attenuation by variable iris control (ND filters not needed)
- Operates with Ophir InGaAs SP1201 camera (purchased separately)



Specifications

Model	Wide Beam Imager VIS	Wide Beam Imager SWIR
Wavelengths	350 ⁽¹⁾ -1100nm	900-1700nm
Active area ⁽²⁾	Ø45mm	Ø45mm
Beam sizes ^{(2),(3)}	10mm– 45mm	10mm– 45mm
Angle of incidence	<70°	<70°
Minimum detail ^{(4),(5)}	0.5mm	0.5mm
Lowest measurable signal	100µW/cm ² ⁽⁶⁾	3µW/cm ² (With Iris fully opened at 1550nm)
Maximum power exposure CW ⁽⁷⁾	200W unlimited, 1000W for 1 minute	50W unlimited time
Maximum energy exposure ⁽⁸⁾	For ns pulses 1.5J/cm ²	N/A
Imager recess supported	4.5mm	17.5 mm (C-Mount)
Camera model recommended	SP932U, SP204S	SP1201
Dimensions	L=265mm X Ø57mm (Ø73mm Iris control)	L=265mm X Ø57mm (Ø73mm Iris control)
Weight (with support)	0.6 kg (0.8 kg)	0.6 kg (0.8 kg)
Part number	SP90612	SP90605

- Notes:
- (1) Camera response down to 350nm. Below this, fluorescence of screen will be imaged
 - (2) Limited to 43 mm in Y direction by camera sensor
 - (3) 5mm possible with reduced accuracy
 - (4) For low contrast artefacts, due to blur effect (~0.8mm)
 - (5) Small diameter evaluation error is < 5%, decreases proportionally with increased diameter
 - (6) With two ND1 filters mounted on camera
 - (7) For WB-I VIS: 20% is backward scattered, WB-I SWIR: 50% is backward scattered
 - (8) At 1.064µm. For wavelengths below 0.9µm, derate to 40% of above, for <0.4µm to 20%

Wide Beam Imager VIS

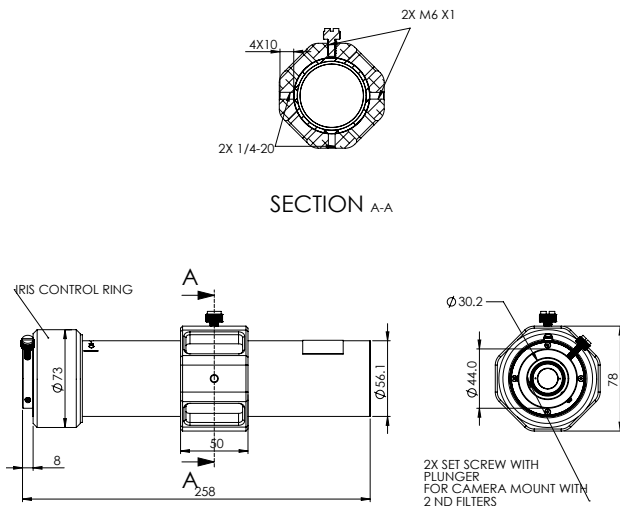

Wide Beam Imager SWIR

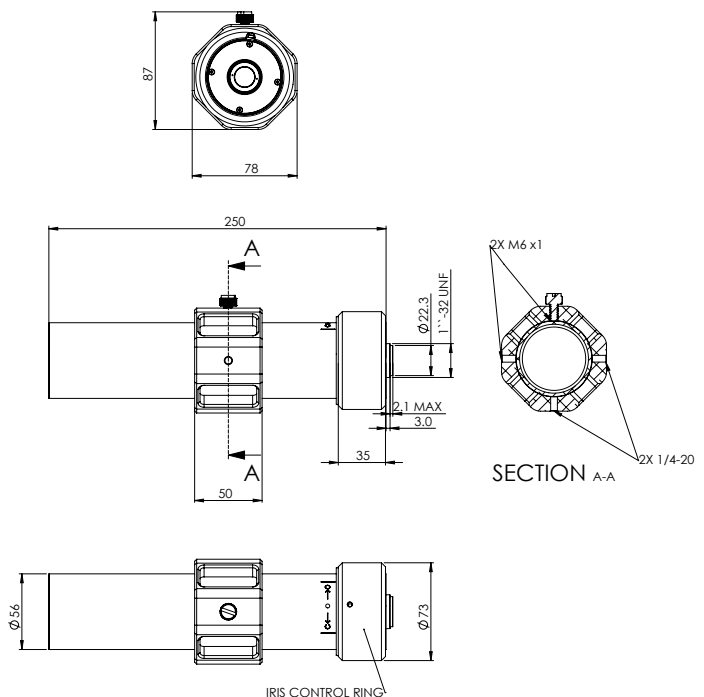

3.5.8 Imaging UV lasers

Integral Reimaging UV Image Converters

The UV image converters are fluorescent plates that convert UV radiation that is poorly imaged by silicon cameras into visible light that is then imaged onto the CCD of the camera. These fluorescent plates are specially designed for UV conversion and have a high light output, wide linear dynamic range and high damage threshold.

There are 3 versions available:

1. The 4X UV image converter is a screw on telescope for large beams that converts to visible and then images onto the CCD while reducing the beam size 4X.
2. The 4X expander with UV converter converts 193 - 360nm to visible and images a beam enlarged 4X onto the CCD.
3. The 1:1 UV image converter is a crew on telescope that convert 1:1 UV image to visible and images the beam onto the CCD without changing the size, fits 4.5mm recess and CS cameras.

All of the above imagers allow a beam splitter to be mounted at 45 deg angle in front of the imager so as to allow imaging of higher power/energy beams.

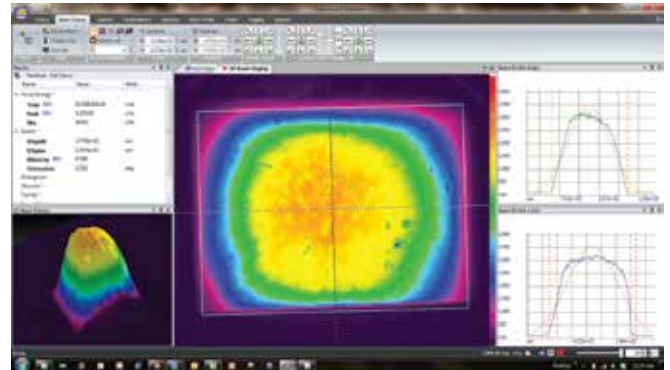

Shown here is a profile of a 355nm UV laser. The beam is converted to a visible wavelength, reduced in size and imaged by the beam profiling camera

Cross section of 4X reducing UV image Converter

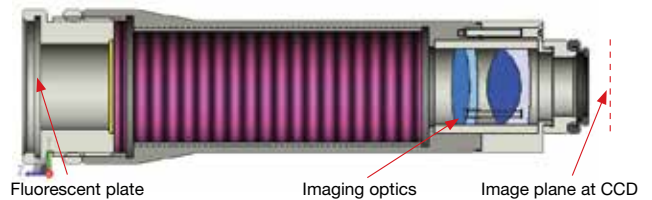

Specifications

Model	4X UV Image Reducing Converter	1X UV Image Converter	4X Beam Expander with UV converter
Beam Reduction	4X reduction $\pm 2\%$ with included correction factor	1:1 imaging $\pm 2\%$ with included correction factor	4X expansion $\pm 2\%$ with included correction factor
Resolution	50 μ m x 50 μ m	35 μ m x 35 μ m	15 μ m x 15 μ m
Wavelengths	193-360nm		
Minimum signal	$\sim 1\mu$ J/cm ² with blank filter		
Saturation intensity	~ 30 mJ/cm ² at 193nm, ~ 15 mJ/cm ² at 248nm with included filter 20 times above values with optional beam splitter	~ 15 mJ/cm ² at 193nm, ~ 20 mJ/cm ² at 248nm with included filter, 20 times greater with optional beam splitter	~ 30 mJ/cm ² at 193nm, ~ 15 mJ/cm ² at 248nm 20 times above values with optional beam splitter
Effective Aperture	$\varnothing 30$ mm but effective beam size is limited to 4X CCD dimensions	$\varnothing 18$ mm but effective beam size is limited to CCD dimensions	1/4 the size of the CCD dimensions
Damage threshold	100W/cm ² or 2J/cm ² with beam splitter		
Dimensions	$\varnothing 50$ mm dia x 185mm length	$\varnothing 31$ mm dia x 120mm length	$\varnothing 29$ mm dia x 69mm length
Part number	SPZ17024	SPZ17023	SPZ17022 + SPZ17019
Accessories			
1st Wedge Splitter (BB)	45 degree wedged beam splitter for 1X UV image converter to reduce intensities on image converter by ~ 20 X. For beam intensities of up to 300mJ/cm ² at 193nm.		SPZ17015
Beam splitter for 4X reducing UV image converter	45 degree wedged beam splitter to reduce intensities by ~ 20 X. For beam intensities of up to 300mJ/cm ² at 193nm.		SPZ17007
20mm diameter UV imaging plate	$\varnothing 20$ mm diameter UV image conversion plate only. For customers that have own imaging system. Converts UV image to visible. For beam intensities 50 μ J/cm ² to 10mJ/cm ² .		SPF01177
30mm diameter UV imaging plate	$\varnothing 30$ mm diameter UV image conversion plate only. For customers that have own imaging system. Converts UV image to visible. For beam intensities 50 μ J/cm ² to 10mJ/cm ² .		SPF01150
50mm X 50mm UV imaging plate	50X50mm diameter UV image conversion plate only. For customers that have own imaging system. Converts UV image to visible. For beam intensities 1mJ/cm ² to 20mJ/cm ² . Not suitable for 193nm.		SP90082



4X beam reducing UV Image Converter as mounted on camera (SPZ17024)



1X UV Image Converter with Optional Beam Splitter (SPZ17023 + SPZ17015)



4X Beam Expander with UV Converter (SPZ17022+SPZ17019)

3.5.9 Integrated Solutions

Ophir has an unparalleled collection of cameras, beam splitters/attenuators, beam expanders, beam reducers, UV to visible light converters, and other components that allow you to profile almost any beam desired. You can profile powers up to thousands of watts using our beam attenuators. You can profile a very wide range of wavelengths from far UV to

far IR. You can profile a focal spot of a converging beam or a diverging beam.

We recommend using “Beam Profiler Finder” to find the optimized configuration that best meets your specific needs: www.ophiropt.com or consult Ophir representative.

Ophir provides adapters that allow you to easily attach and align these devices to each other as shown below.

The image displays various Ophir components categorized into several groups:

- Beam Splitters / attenuators:** LBS-300s, LBS-400, LBS-100, and Stackable Beam Splitters.
- Beam expanders / reducers:** 4X Beam Expander, 6X / 12X / 22X Beam Expanders, and 4X Beam Reducer.
- Filters:** Additional neutral density filters in black, red, and green.
- InGaAs cameras:** SP1203 high resolution and SP1201.
- Pyroelectric cameras:** Pyrocam IIIHR, Pyrocam IV, and SP402S.
- Scanning profilers:** NanoScan 9/5 and NanoScan 3.5/1.8.
- Small and large aperture Si cameras:** SP932U, SP402S, and SP504S.

Examples

1. LBS-300s mounted to a 4X beam expander, connected via ND filters to a camera: for measuring of spots that are smaller than 44µm



2. LBS-400 mounted to Wide Beam Imager with camera: for large or diverging beams, requiring attenuation or in case of no space to place the WB-I.



Adapters/spacers that are needed to connect various components together. When blank, no connection or not recommended to connect.

P/N		LBS-100	LBS-300s	LBS-400	Stackable beam splitters		
					SPZ17027 + SPZ17025	SPZ17015 + SPZ17025	SPZ17015 + SPZ17026
SPZ17022	4X beam expander		SP90567 + SPG01698		Direct connection		
SPZ17022+SPZ17019	4X beam expander UV converter		Direct connection			Direct connection	
SPZ08257	6X beam expander		SP90567 + 4ea. SPG02067			SP90567+ 2ea. SPG02067	
SPZ08259	12X beam expander		SP90567 + 3ea. SPG02067			SP90567	
SPZ08260	22X beam expander		SP90567			SP90567	
SPZ17017	4X beam reducer	SPZ17029	SP90569	SP90570			SP90569
SPZ17024	4X beam reducer UV converter		SP90569	SP90570			SP90569
SPZ17023	1X UV converter		Direct connection				Direct connection
SP90618	SP504S	SP98001		SP98000			
SP90612/SP90605	WB-I VIS/WB-I SWIR			SP90572			
SP90405/415	Pyrocam IIIHR		Supplied with Pyrocam	SP90510			Supplied with Pyrocam
SP90404/414	Pyrocam IV		SP90573	SP90510			SP90573
PH00457/459/460/462/464/465/467/468/470	Nanoscan	Direct connection	Direct connection			Direct connection	
	All C-Mount thread cameras	Direct connection	Direct connection	SP90352		Direct connection	

3.5.10 Optical Camera Trigger

The Optical Camera Trigger is an optical sensor that detects pulsed light sources and generates outputs to trigger a camera. The front aperture of the Optical Trigger must be directed at a light source that provides the necessary properties for trigger activation (e.g. a laser flash lamp, a pick-off source from the main laser beam, or similar). The light source may be a direct or indirect pulsed waveform.

The Optical Trigger system is supplied with a C-Mount adapter, a 1/4-20 adapter, M6-1.0 adapter, or Through-Hole adapter options which allows attachment of the Optical Trigger in a multitude of mounting configurations. One trigger cable and one mount option comes with the photodiode trigger. Specify one of each at time of order. See user guide for camera specific mounting options.



Specifications

Model	Photodiode Trigger, Si, 1100	Photodiode Trigger, InGaAs, 1800
Detector	Si	Si/InGaAs
Minimum pulse width	1µs	1µs
Optical Threshold Wavelength		
200nm	10.0 1µJ	N/A
633nm	3.5 1µJ	4 1µJ
1064nm	5 1µJ	10.0 1µJ
1550nm	N/A	4 1µJ
Compliance	CE, UKCA, China RoHS	CE, UKCA, China RoHS
Part number	SP90408	SP90409

Accessories

With either trigger above you must specify 1 cable and 1 mount at time of order

Cable	Photodiode Trigger Cable for SP300, 6ft	SP90430
Cable	Photodiode Trigger Cable for SP907, SP932U, SP203P, SP204S, SP402S, 6ft	SP90431
Cable	Photodiode Trigger Cable to SMA for LT665, Pyrocam™ IIIHR & IV, SP1203, SP1201, 6ft	SP90432
Cable	Photodiode Trigger Cable to BNC for SP920G, SP504S, L11059, Xeva, Pyrocam III, 6ft	SP90433
Mount	1/4-20 Mount, Photodiode Trigger	SP90434
Mount	M6 X 1.0 Mount, Photodiode Trigger	SP90435
Mount	Thru Hole Mount, Photodiode Trigger	SP90436
Mount	C-Mount, Photodiode Trigger	SP90437

Mounting Options

Photodiode Trigger

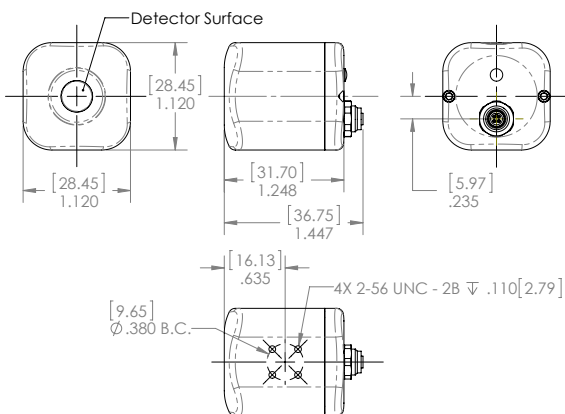

SP90437 C-Mount Mounting Plate & Locking Ring



SP90436 Through Hole Mounting Plate



SP90434 1/4-20 Mounting Plate



SP90435 M6 X 1.0 Mounting Plate

3.6 Near Field Profilers

Camera Based Near-Field Profiler

- Allows measurement of beams normally too small for camera profiler
- Expands beam to reduce power/energy density
- Provides near-field profile of fibers, LD junctions, and other small sources
- Can be used to measure tightly focused beam with camera and attenuation
- Nominal 10X, 20X, 40X, 60X Beam expansion available
- Easily calibrated to provide absolute measurement values
- Built-in continuously variable attenuation
- C-mount for attachment to any silicon CCD camera profiler
- Camera and BeamGage software purchased separately

Near field profiling can also be used with camera profilers to analyze small beams, and involves a microscope objective lens to image the beam onto a camera detector array. This technique expands the measurement range of the camera to include smaller beams, which could not be ordinarily measured due to the pixel size of the detector array. Near field profiling is performed in fiber and waveguide analysis, lens characterization, and other applications where beams 50 microns or smaller are analyzed. While there are more accurate techniques to measure these beam sizes, the camera provides two-dimensional information that cannot always be obtained through knife-edge or scanning slit

methods. This camera accessory includes base plate for mounting camera and Microscope Objective, ATP-K variable attenuator, 50mm C-Mount and an 8mm and 5mm spacer. User selectable magnification lenses, camera and BeamGage must be purchased separately.

The near field of the test beam or sample is imaged with the microscope objective lens and relayed to the camera. The bracket mounting fixture holds both the lens and camera, which itself can be mounting on a positioner or optical rail. This complete system provides everything necessary to perform near-field measurements right out of the box.

C-mount NFP Adapter Assembly

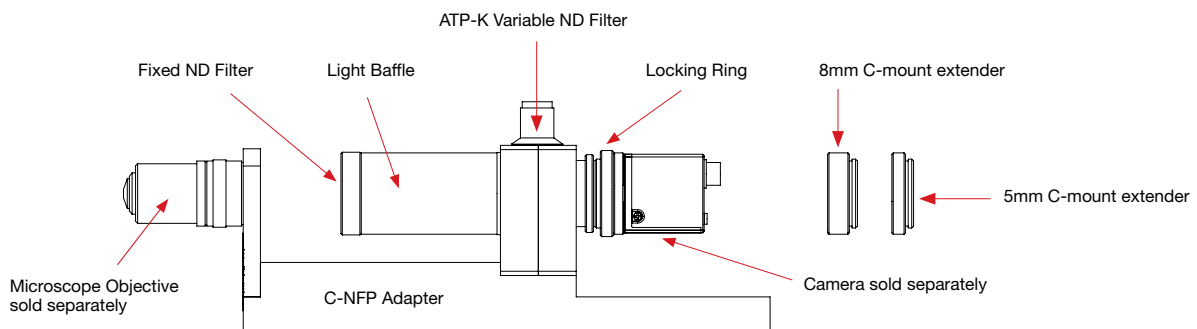

Ordering Information

Item	Description						P/N
C-NFP Assy	Includes base plate for mounting camera and Microscope Objective, ATP-K variable attenuator, 50mm C-Mount and an 8mm and 5mm spacer						SP90291
Item	Description	Power	Effective Focal Length (mm)	Field of View (mm)	Working Distance (mm)	NA	P/N
60X	60X, Microscope objective	60X	3.21	0.30	0.15	0.85	SP90292
40X	40X, Microscope objective	40X	4.35	0.45	0.60	0.65	SP90293
20X	20X, Microscope objective	20X	8.33	0.90	3.75	0.40	SP90294
10x	10X, Microscope objective	10X	17.02	1.80	4.40	0.25	SP90295

3.7 What is M²?

M² or Beam Propagation Ratio, is a value that indicates how close a laser is to being a single mode TEM₀₀ beam, which in turn determines how small a beam waist can be focused. For the perfect Gaussian TEM₀₀ condition the M² equals 1.

For a laser beam propagating through space, the equation for the divergence θ_0 of an unfocused beam is given by:

$$\theta_0 = M^2 4\lambda/\pi D_0 \quad (D_0 \text{ is the waist diameter of the laser beam})$$

For a pure Gaussian TEM₀₀ beam M² equals 1, and thus has no impact on the calculation. The calculation of the minimal beam spot after the lens is then:

$$d_0 = 4\lambda/\pi\theta \quad (\theta \text{ is the beam divergence after the lens})$$

Again with M² equal to 1, the focused spot is diffraction limited. For real beams, M² will be greater than 1, and thus the minimum beam waist will be larger by the M² factor.

How is M² measured?

M² cannot be determined from a single beam profile measurement. The ISO/DIS 11146 requires that M² be calculated from a series of measurements as shown in figure 1. M² is measured on real beams by focusing the

beam with a fixed position lens of known focal length, and then measuring the characteristics of the artificially created beam waist and divergence.

To provide an accurate calculation of M², it is essential to make at least 5 measurements in the focused beam waist region, and at least 5 measurements in the far field, two Rayleigh ranges away from the waist area. The multiple measurements ensure that the minimum beam width is found. In addition, the multiple measurements enable a “curve fit” that improves the accuracy of the calculation by minimizing measurement error at any single point. An accurate calculation of M² is made by using the data from the multiple beam width measurements at known distances from a lens, coupled with the known characteristics of the focusing lens.

M² Measurement Solutions

Ophir-Spiricon have a number of solutions for the measurement of M² ranging from simple manual processes to fully automated dedicated instruments, depending on the frequency of the need to measure M² of lasers and laser systems. We have a system that will meet most needs, whether for research and development of new laser systems, manufacturing quality assurance, or maintenance and service of existing systems.

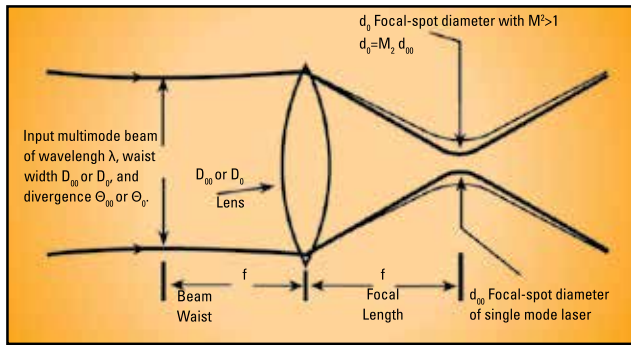

Figure 1 - Characteristics of a laser beam as it passes through a focusing lens

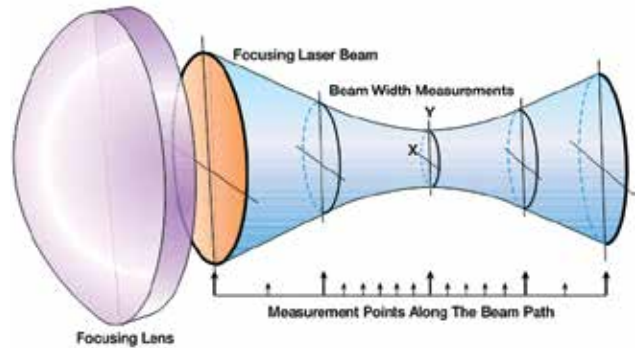

Figure 2 - focusing laser beam

3.7.1 Camera Based Beam Near-Field Propagation Analyzer: M^2

3.7.1.1 BeamSquared®

- ISO compliant
- Automatically measure your beam quality in under 1 minutes
- Tune your laser for best operation
- Specifically developed for continuous usage
- Unequaled accuracy using patented Ultracal™ Calibration
- Long optical train & automatic attenuation adjustment
- Flexible mounting configurations, install horizontal or vertically
- Pulsed and CW for most beam diameters and powers
- Compact and portable
- Detectors from 266nm to 10.6μm

The BeamSquared® system is a compact and fully automated tool for measuring the propagation characteristics of CW and pulsed laser systems from the UV to NIR to Telecom wavelengths. Users can also measure wavelengths above 1.8 microns, including CO₂ and terahertz in manual mode (a bench set-up; without the automated optical train) with a Pyrocam™ IV or IIIHR. Our longer optical train and patented Ultracal™ Calibration makes BeamSquared the most accurate product on the market and is ISO 11146 compliant. Its operational robustness and reliability ensures continuous use applications in industry, science, research and development.

Automatic M^2 - at Production Speeds

The BeamSquared optical train uses a fixed position lens with movable mirrors and camera. The mirrors that direct the focused beam into the camera are moved to precise locations, translating the beam through the near field, the waist, and the far field regions. All these measurements and translations, as well as incremental beam attenuation, are automatically controlled by the BeamSquared software. Design improvements in the BeamSquared system have decreased the measurement reporting time by 2-3 times, making it possible to report M^2 in under a minute.

Manual M^2

Manual mode is available for wavelengths greater than NIR, particularly Terahertz and above, and for beams that are too large or too small for the BeamSquared optical system. Users are required to provide a manual translation/attenuation apparatus.

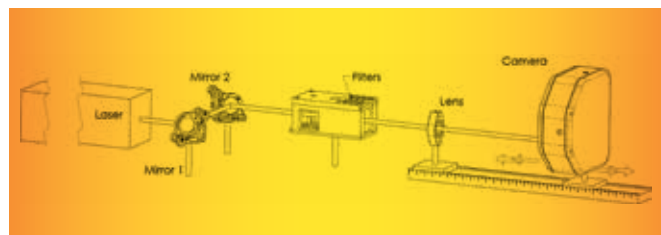
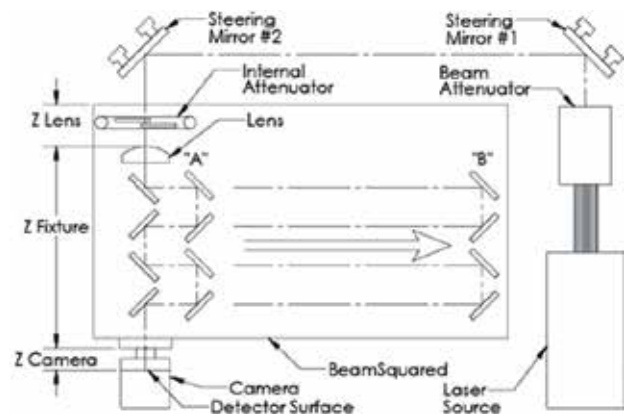
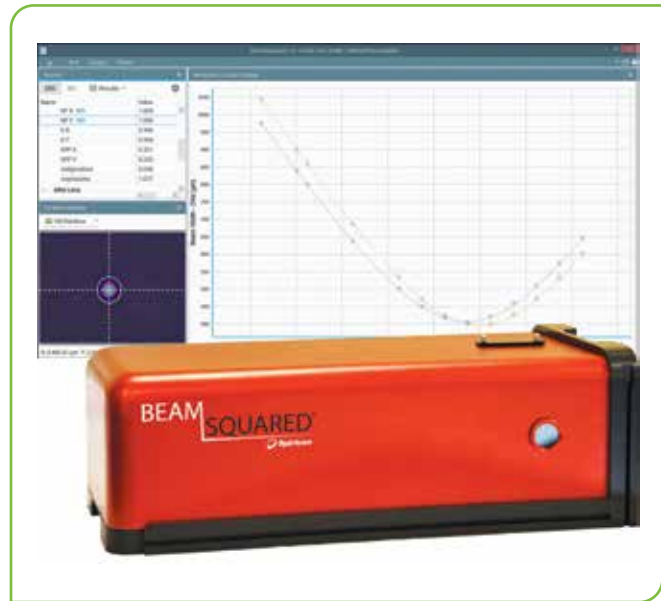

Software Features

Features	
Measurements	<ul style="list-style-type: none"> M^2_x, M^2_y, K_x, K_y, BPP_x, BPP_y Width at waist W_x, W_y Divergence angle Q_x, Q_y Waist location Z_x, Z_y Rayleigh X, Y Astigmatism Asymmetry ratio Statistical results are available on all measurements
Supports both automated and manual runs	
New Hardware	<ul style="list-style-type: none"> Allows standalone computer control of BeamSquared motion system Camera Options include: SP920, SP204S, Xeva, Pyrocam™ III HR or IV RF Lens Reader <ul style="list-style-type: none"> • Lens must be present for operation • Lens configuration data stored with lens (Focal length, calibration wavelength, material, etc.) Shutter only open when in live mode Table and attenuator calibration at startup (homing before each run)
Supports hardware Trigger	
Faster run times than M^2 -200s	
New Interface	<ul style="list-style-type: none"> Selectable theme colors Splash screen with progress bar
2D display	<ul style="list-style-type: none"> Selectable Color Palette Manual Cursor when not running (Cursor at centroid otherwise)
Caustic Display	<ul style="list-style-type: none"> Selecting individual frames Auto Aperture Exclude points from run
Run Info Display	<ul style="list-style-type: none"> Displays Caution Notice when beams are non-conforming: (too dark, too bright, misaligned, too large or too small) Option to ignore misaligned beams
Editable Settings (Wavelength, Laser to box distance, Laser to lens and focal length in manual mode)	
Calculations	<ul style="list-style-type: none"> Frame Results (Total, Min, Peak, % in Aperture, Avg Pwr Density, Beam Width, Centroid, Peak, Cross Sectional Area) Laser Results (Waist Width, Divergence, Waist Location Rayleigh Length, M^2, K, BPP, Astigmatism, Asymmetry) After Lens Results (Waist Width, Divergence, Waist Location Rayleigh Length, Astigmatism, Asymmetry) Effective Focal Length of lens Fitted/Measured Divergence Supported Beam Width calculations <ul style="list-style-type: none"> • D4 Sigma • Knife Edge 10/90 and Programmable • EPSA - Encircled Power Smallest Aperture (power in a bucket)
Multiple Runs	<ul style="list-style-type: none"> Result statistics Progress Indicator
Single Page Report	<ul style="list-style-type: none"> Setup information Results Statistics Caustic chart
Logging/Export data	.CVS File
BeamSquared motion utility which allows standalone computer control of BeamSquared motion system	

Accuracy by Design

Spiricon products are known for accuracy. Using our patented Ultracal calibration method, auto aperturing to exclude noise beyond the wings of the laser beam, and long optical path, assures the user of the most accurate measurements in the industry.

Designed by Our Customers

Guided by customer input from our widely deployed previous generation M²-200s system, Spiricon redesigned the BeamSquared® to meet the challenging demands of the laser industry. The new BeamSquared system has significantly higher durability and operational robustness for continuous use in a three shifts a day, seven days a week environment. The rigid baseplate and internal optics greatly simplifies and reduces the time for initial set-up and alignment. The lens configuration data is now stored using an RF ID chip embedded in the lens holder which is uploaded automatically by the BeamSquared system when the lens cartridge is inserted in the system, eliminating the need for our customers to keep track of configuration file. Both novice and seasoned users will appreciate these new features along with the time-tested excellence that Spiricon has provided over the years.

Measurements

BeamSquared measures propagation characteristics in both the X and Y axes and displays the following parameters:

- Waist diameters
- Full angle Divergences
- Waist locations
- Rayleigh lengths
- M² or K and BPP factors
- Astigmatism
- Asymmetry

To optimize bench space, BeamSquared can be mounted either horizontally or vertically. Laser beam input port is the same dimension with either mounting method, X = Y, and the same as the M²-200s that it is replacing.



Main Screen Functions

This window displays quantitative measurements of the laser parameters. These include the X and Y beam widths, M² or K, the divergence angles, the Rayleigh range, and other parameters shown.

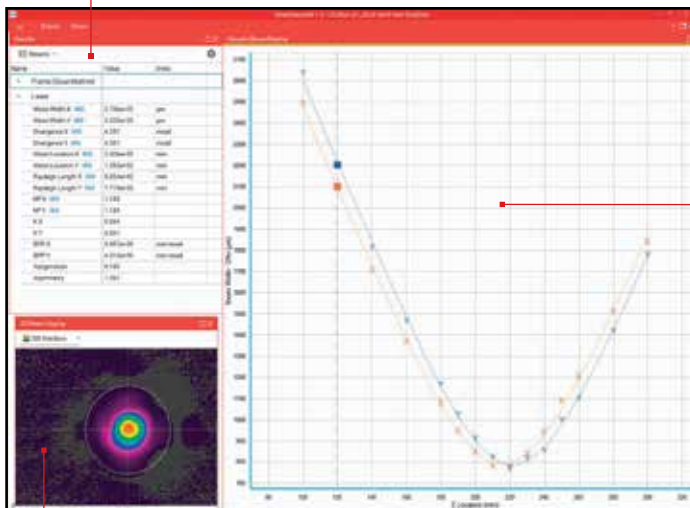

This window presents measurements of beam width vs. position for a given run. After measuring a few points, the software extrapolates a curve fit. The Xs and Ys represent individual measurement points. The solid lines present the best fit hyperbola of the beam propagation equation to the measured points. The M² and other laser parameters are computed from the best fit hyperbola since it provides a smoothing of the data points.

This window displays the 2D or 3D beam profile of the currently measured point in the beam propagation curve. This image enables visual intuitive verification of the beam profile behavior through focus. After each run the user can click any individual measured point and observe the beam profile. Outlying or anomalous points can be automatically or manually excluded from the curve fit calculations for more accurate results.

Specifications

Model	BSQ-SP204S	BSQ-SP1203 ⁽⁹⁾	BSQ-A	BSQ-PY-M
Beam Profiling				
Camera model	SP204S	SP1203	BeamSquared® software, software license, and optical train, no camera included	Pyrocam™ IIIHR or Pyrocam™ IV Software only, camera and optical train not included. See individual camera data sheets
Sensor type	Silicon CMOS	InGaAs		
Wavelengths	266 – 1100nm ⁽¹⁾	900 – 1700nm ⁽²⁾		
Active area	6.7mm x 5.6mm	9.6mm x 7.6mm		
Elements	2472 x 2064	640 x 512		
Effective pixel	2.74µm x 2.74µm	15µm x 15µm		
Dynamic range	67 dB	68dB		
Frame rate	37 fps	60 fps		
Interface	USB 3.0			
Accuracy	±5% typical, ±10% waist location and Rayleigh length typical			
Measurement cycle time	<1 minute typical, depending on setup conditions and operating mode			
Camera attachment	Standard C-mount, 90° camera on axis rotation			
Translation system	Step-motor driven ball screw			
Translation stage resolution	0.05mm			
Standard optics				
Lenses included ⁽³⁾	266-440nm UV 500mm FL 430-700nm VIS 500mm FL 650-1000nm NIR 400mm FL 1000-1700nm Extended NIR 600mm FL	1000-1700nm Extended NIR 400mm FL 650-1000nm NIR 400 FL	266-440nm UV 500mm FL 430-700nm VIS 500mm FL 430-700nm VIS 400mm FL 650-1000nm NIR 400mm FL 1000-1700nm Extended NIR 400mm FL	N/A
Optional lenses ⁽⁴⁾⁽⁵⁾ *Not part of the standard BSQ kit	266-440nm UV 750mm FL 266-440nm UV 1000mm FL 430-700nm VIS 750mm FL 430-700nm VIS 1000mm FL 650-1000nm NIR 750mm FL 1000-1550nm Extended NIR 750mm FL	650-1000nm NIR 750mm FL 1000-1550nm Extended NIR 750mm FL	266-440nm UV 750mm FL 266-440nm UV 1000mm FL 430-700nm VIS 750mm FL 430-700nm VIS 1000mm FL 650-1000nm NIR 750mm FL 1000-1550nm Extended NIR 750mm FL	N/A
Attenuation range				
	Nominally from ND 1.0 to ND 4.8. Actual values vary with wavelength.			N/A
Damage limits⁽⁶⁾				
	0.15 mW/cm ² CW mode 1.0 µJ/cm ² pulse mode Both of the above for an M ² =1 @ 1064nm	100 mW/cm ²	Depends on type of the camera	See camera data sheets
Optical limits				
Wavelengths ⁽⁷⁾	266 - 1100nm	900 - 1700nm	Depends on type of the camera	1.06 - 3000µm
Beam size	BeamSquared Auto Mode 1mm – 10mm Varies with wavelength, waist size, location, and M ²			Pyrocam IIIHR 0.8mm – 10mm max Pyrocam IV 0.8mm – 20mm max Depends on customer mechanics and lens
Minimum beam width	27µm	150µm	N/A	800µm
Software				
BeamSquared Software	Fast scan method (1 minute) for automatic (ISO) and manual M ² measurement, Windows 11 (64)			
General				
Storage temperature	-30° C to 65° C			N/A
Storage humidity	95% maximum (non-condensing)			N/A
Operating temperature	10° C to 40° C			N/A
Operating humidity	95% maximum (non-condensing)			N/A
Power requirements⁽⁸⁾				
Input voltage	90 – 264 V AC			N/A
AC Line current	1.6 A			N/A
Line frequency	47Hz to 63Hz			N/A
Weight	26 lbs. w/o camera			N/A
Dimensions	217.2mm X 459.5mm X 156.3mm			N/A
Compliance	CE, UKCA, China RoHS			
Ordering information				
Part Number	SP90630	SP90644 ⁽⁹⁾ : BSQ-A-SP1203 SP90524 ⁽⁹⁾ : SP1203 Camera SP90645 ⁽⁹⁾ : BSQ SP1203 License Kit	SP90445	SP90410

- Notes: (1) If device is used below 300 nm, measurement accuracy may degrade and long-term intensive irradiation at UV wavelengths may cause permanent damage to the imager.
(2) For wavelengths between 1300-1400nm inner reflections have been observed that may impact beam measurement
(3) Different lenses are required for different wavelength regions, spot sizes and divergences, Additional lenses must be ordered separately.
(4) For selection of optimal BeamSquared lens, use Beam Profiler Finder.
(5) These lenses have been calibrated for measurement of lasers with Rayleigh length up to 20 meters, for longer Rayleigh lengths, please use Beam Profiler Finder.
(6) Damage threshold listed is based on products with similar design. Silicon cameras can be damaged by power in excess of 0.15 mW/cm² or energy in excess of 1 µJ/cm². BeamSquared employs a focusing optic. While it may be that the laser input power or energy measures well below this damage threshold, it can easily exceed these levels when focused onto the camera sensor. Use caution and error on the side of safety. Cameras can be costly to repair or replace.
(7) For UV lasers 245-440nm, it is recommended to use the UV reflective ND2 filter P/N SP90568
(8) For the optical train only. The PC computer supplies the power for the system components, such as the USB3 camera.
(9) For the BSQ-SP1203 you need to order the 3 P/Ns above

Accessories Ordering Information

Item	Description	P/N
BSQ-SP204S-A	An SP204S camera licensed for BeamSquared®. Sold as an accessory for those also purchasing a BSQ-XC130	SP90631
BSQ-Lens Kit UV-XNIR	Lens kit that includes 4 BeamSquared lenses: 500mm UV, 500mm VIS, 400mm NIR, 600mm XNIR	SP98009
BSQ-Lens Kit 266-1550	Lens kit that includes 5 BeamSquared lenses: 500mm UV, 500mm VIS, 400mm NIR, 400mm XNIR	SP90449
BSQ-Lens Kit 650-1700	Lens kit that includes 2 BeamSquared lenses: 400mm NIR, and 400mm XNIR.	SP90450
BSQ-Lens UV 500mm	Single BeamSquared lens, 500mm focal length, A/R coated for 266-440nm	SP90451
BSQ-Lens VIS 500mm	Single BeamSquared lens, 500mm focal length, A/R coated for 430-700nm	SP90452
BSQ-Lens VIS 400mm	Single BeamSquared lens, 400mm focal length, A/R coated for 430-700nm	SP90453
BSQ-Lens NIR 400mm	Single BeamSquared lens, 400mm focal length, A/R coated for 650-1000nm	SP90454
BSQ-Lens XNIR 400mm	Single BeamSquared lens, 400mm focal length, A/R coated for 1000-1550nm	SP90455
BSQ-Lens XNIR 600mm	Single BeamSquared lens, 600mm focal length, A/R coated for 1000-1550nm	SP90485
BSQ-Lens UV 750mm	Single BeamSquared lens, 750mm focal length, A/R coated for 266-440nm	SP90554
BSQ-Lens VIS 750mm	Single BeamSquared lens, 750mm focal length, A/R coated for 430-700nm	SP90555
BSQ-Lens NIR 750mm	Single BeamSquared lens, 750mm focal length, A/R coated for 650-1000nm	SP90556
BSQ-Lens XNIR 750mm	Single BeamSquared lens, 750mm focal length, A/R coated for 1000-1550nm	SP90557
BSQ-Lens UV 1000mm	Single BeamSquared lens, 1000mm focal length, A/R coated for 266-440nm	SP90558
BSQ-Lens VIS 1000mm	Single BeamSquared lens, 1000mm focal length, A/R coated for 430-700nm	SP90559
BSQ SP300 or SP920 to SP204S Upgrade	Camera upgrade	SP90632
BGS license for BSQ-SP204S	Includes BeamGage Standard software license in addition to BeamSquared software license	SP90633
BGP license for BSQ-SP204S	Includes BeamGage Professional software license in addition to BeamSquared software license	SP90634
BGP license for BSQ-XC130	Includes BeamGage Professional software license in addition to BeamSquared software license	SP90508
BGP license for BSQ-SP1203	Includes BeamGage Professional software license in addition to BeamSquared software license	SP90646
BSQ - UV Reflective Filter	BeamSquared reflective ND2 filter, UV Grade Fused Silica, Inconel coating for 245-440nm	SP90568

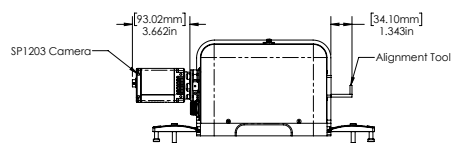
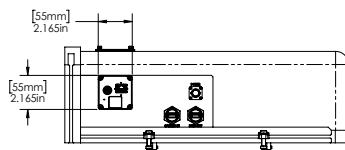
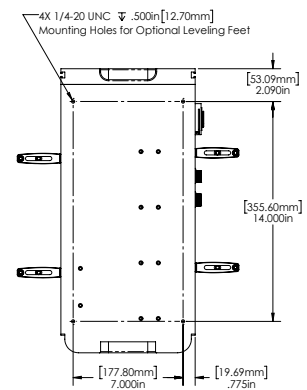
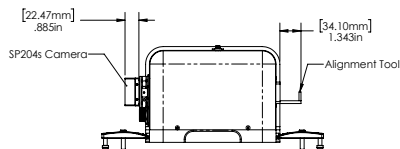
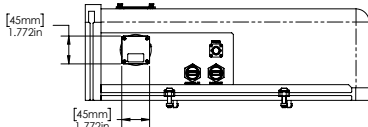
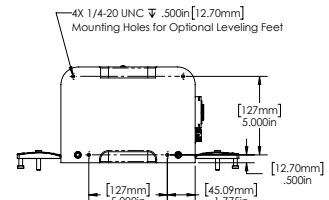
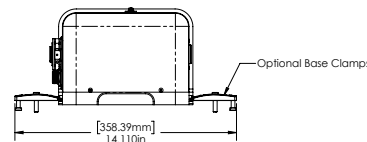
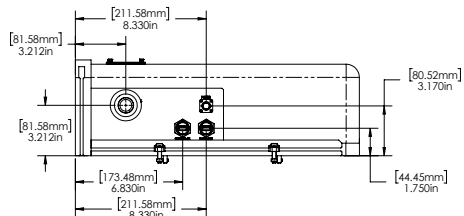
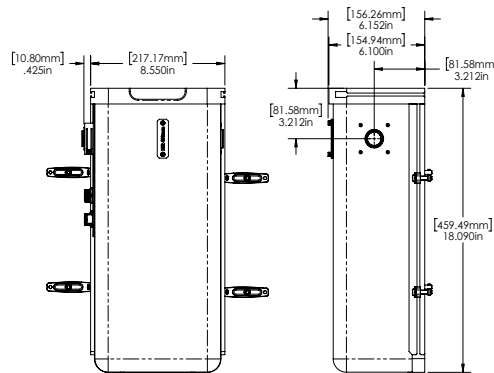
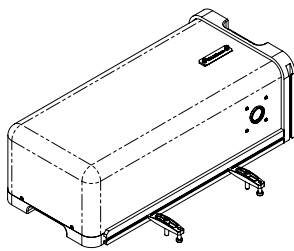

3.8 BeamWatch® Family

The BeamWatch family of products is the first to make use of Rayleigh scattering measurement to perform non-contact measurement of high power lasers.

3.8.1 Introduction To Rayleigh Scattering Measurement Technology

Disruptive Technology

BeamWatch is the first device to measure a laser without coming in contact with its beam which allows it to be the first laser quality measurement product in history to have no upper limit on the lasers which it can measure. BeamWatch provides high-power industrial laser users with data never before seen such as the dynamic measurement of focus shift caused by thermal effects on the laser system. BeamWatch also provides the industrial laser user with measurement of other key laser operating parameters in real-time.

The system measures the signal generated from Rayleigh scattering around the laser's beam waist, where the power density is the highest. Rayleigh scattering is a physical property of light caused by light scattering off of air molecules. Unlike traditional beam measurement systems, the beam passes directly through BeamWatch and is not disrupted, mechanically or optically. In addition, BeamWatch has no moving parts so there is no need for cooling of any components. Specialized system software dynamically measures the signal multiple times per second, allowing the laser user to key in on critical operational laser attributes, such as beam waist size and position with respect to the material being processed.

BeamWatch User Interface

The user has access to those tools needed for start-up and advanced beam diagnostics.

Focus Spot Size (Waist Width)

BeamWatch images the full beam caustic measuring the waist at its smallest point, many times per second.

Focus Spot Location

Now you can precisely know the dynamic behavior of focal spot shift throughout the laser duty cycle. By inputting the known distance from the laser delivery head to a precise datum on BeamWatch the focal spot distance is constantly measured and tracked with millisecond updates.

Assured Process Consistency

Measure as often as needed to assure repeatable and consistent process uniformity. Mount BeamWatch into the process or manually insert BeamWatch and make periodic measurements.

You can also automatically compare to initial process validation measurements and utilize automated pass/fail.

Automation Interface

BeamWatch includes the tools to support Automation Clients written in Visual Basic for Applications (VBA), C++ CLI, or any .Net compliant environment, such as Microsoft Excel or National Instruments' LabVIEW.

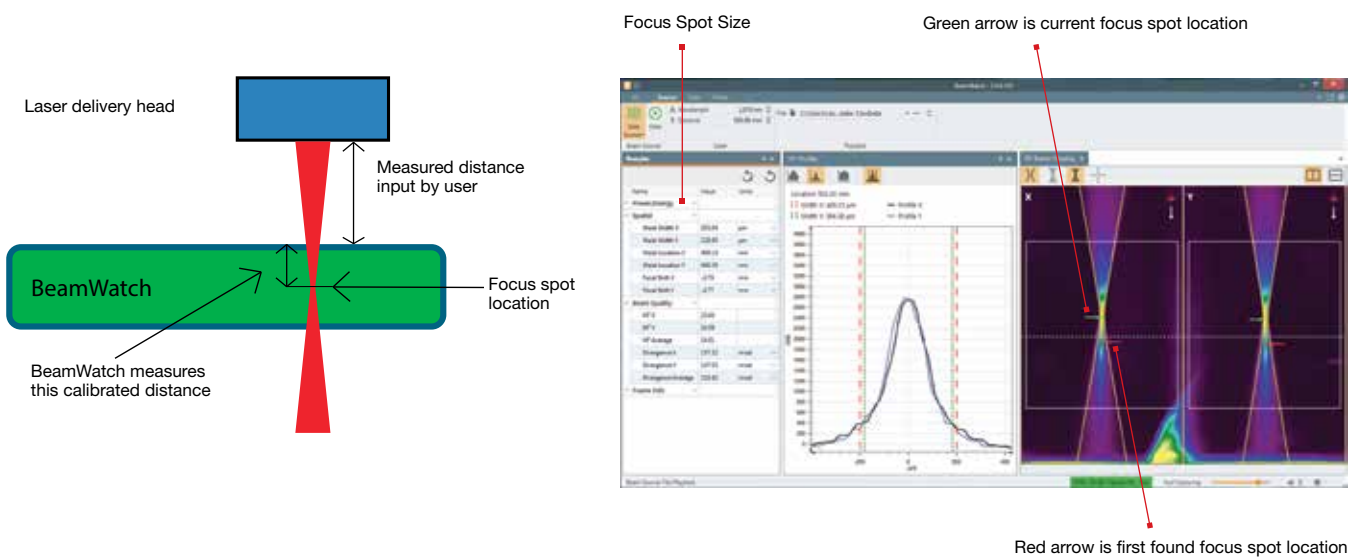

Software Features

Features	Dual Axis
Results - Power/Energy	Relative Power (Absolute Power when configured with Juno and an Ophir Power Meter)
Results - Spatial	Waist Width X & Y Waist Location X & Y Focal Shift X & Y Centroid X & Y Width at Cursor X & Y Ellipticity at Cursor Rayleigh Length X & Y Waist to Cursor X & Y
Results - Beam Quality	M ² X & Y M ² Average K X & Y K Average BPP X & Y BPP Average Divergence X & Y Divergence Average
Results	All results can be shown/hidden.
Frame Info	Frame ID Timestamp
1D Profile	Logarithmic or Linear Control to enable/disable the beam width markers Profiles are drawn at the cursor location. Cursor is controlled in the 2D display Display shows current cursor location and width at cursor results The X and Y profiles are overlapped in a single display
2D Beam Display	Overlays that can be enabled/disabled Fitted caustic and drawn beam area Raw data points Beam Image Alignment Crosshair – Marks the center of the display for each axis Beam can be displayed vertically or horizontally on the screen Labels indicate X and Y axis and the direction of beam propagation Cursor can be moved to any point along the beam Focal point indicators – one shows current waist position, another shows first found waist position
Statistics	Mean, Std Dev, Max, Min, and Sample Size
System Requirements	PC computer running Windows 7 (64) and Windows 10 Laptop or Desktop: GHz Pentium style processor, dual core recommended Minimum 2GB RAM Accelerated Graphics Processor Hard drive space suitable to hold the amount of video data you expect to store (50-100 GB recommended)

3.8.2 BeamWatch® & BeamWatch®Plus Non-contact, M², Focus Spot Size and Position Monitor for high power NIR and VIS lasers

- Instantly measure focus spot size
- Dynamically measure focal plane location during start-up
- From 400W for NIR (3W for VIS) and up - no upper limit (So far, up to 100kW was measured)
- Non-contact, laser beam is completely pass-through
- Automation Control Interface for System Integration
- GigE camera interface for local network installation
- Patented



BeamWatch utilizes disruptive technology to measure laser beam characteristics of very high power lasers. By not intercepting the beam and yet providing instantaneous measurements, you can now monitor the beam at frequent intervals without having to shut down the process or remove tooling and fixtures to get access. In addition, you can now measure focal spot location at several times per second and know if there is any focal spot shift during those critical start-up moments.

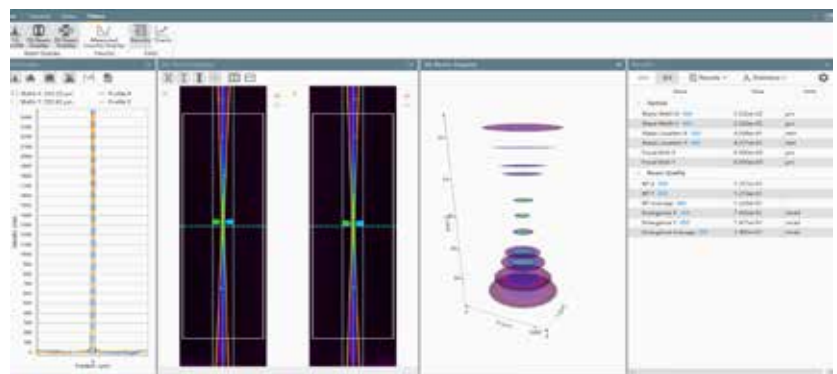

The BeamWatch software accurately analyzes in real time the laser waist size and position, focal shift, M², divergence and other parameters essential for industrial laser applications.

BeamWatch®Plus

The BeamWatch®Plus is capable of measuring both NIR and VIS high-power lasers with small focal spots while the BeamWatch® designated for high-power lasers with larger focal spots at NIR.

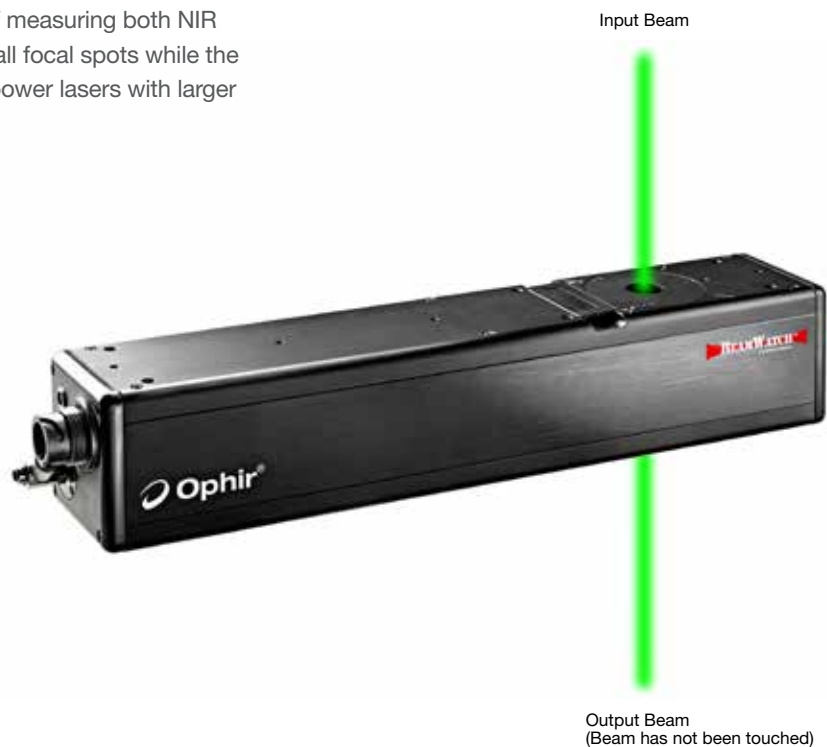

Specifications

Model	BW-NIR-130	BW-PLUS-45
Beam Profiling		
Wavelengths	950-1100nm	420-635nm 950-1100nm
Minimum Linear Power density ⁽¹⁾	15 kW/cm	230 W/cm 34 kW/cm
Minimum Power	400 W	3 W 400 W
Minimum spot size	130 µm ⁽²⁾	45 µm
Maximum Power	No limit	No limit
Field of View (FOV)	25.74mm x 8.55mm	9.01mm x 2.99mm
FOV resolution	16.5µm	5.5µm
Max Rayleigh Range	8.5mm	3mm
Maximum beam diameter at entrance/exit ⁽³⁾	12.5mm	12.5mm
Distance from top to center of FOV ⁽⁴⁾	39.7mm	39.7mm
Accuracy⁽⁵⁾		
Waist width (Spot size)	±5%	±5%
Waist location	±125 µm	±125 µm
Focal shift	±50 µm	±50 µm
Beam parameter product	±2% RMS	±2% RMS
Divergence	±2% RMS	±2% RMS
M ²	±2% RMS	±2% RMS
General		
Communication to PC	GigE	GigE
Power supply	12 Volts DC, 1.67 Amps max, 100-240V AC	12 Volts DC, 1.67 Amps max, 100-240V AC
Particulate purge	Clean Dry Gas, approximately 35 PSI / 2.5 BAR Particle size < 5µm, oil and water free	Clean Dry Gas, approximately 35 PSI / 2.5 BAR Particle size < 5µm, oil and water free
Weight	3.9 Kg	3.9 Kg
Dimensions	16in x 7in x 35in 406.4mm x 177.8mm x 88.9mm	16in x 7in x 35in 406.4mm x 177.8mm x 88.9mm
Operating / Storage Temperature	10 to 40°C / -20 to 80°C	10 to 40°C / -20 to 80°C
Operating / Storage Humidity	20% to 80%, relative, non-condensing	20% to 80%, relative, non-condensing
Compliance	CE, UKCA, China RoHS	CE, UKCA, China RoHS
Ordering information		
Part Number	SP90623	SP90613

- Notes: (1) Linear Power Density calculated by Power / beam diameter.
 (2) Minimum spot size possible down to 125µm with additional 2% error.
 (3) OEM solutions available for larger aperture needs.
 (4) Cup aperture accessory (SP90476) has a 23.8mm distance to the center of the FOV. The deep cup accessory (SP98008) for BW-PLUS-45 only has a 12mm distance to the center of the FOV.
 (5) Specified accuracy for beam tilt < 5°.

Suggested Add-Ons

Item	Description	P/N
Cup aperture for BW-NIR-130	For applications requiring closer positioning of laser to center of FOV. Enables down to 23.8mm distance to the center of the FOV	SP90476
Cup aperture for BW-Plus-45	Enables down to 12mm distance to the center of the FOV	SP98008
Rotation Mount	Add-on 180° manual rotation mount to bottom of BeamWatch	SP90346
Locking Ethernet Cable	Replace standard Ethernet cable with one that locks into place, IP67 rated	SP90394
5000W-BB-50	5kW water cooled power sensor	7Z07111
10K-W-BB-45-V4	10kW water cooled power sensor	7Z07102
30K-W-BB-74-V4	30kW water cooled power sensor	7Z07136
120K-W	Calorimetric, 120kW water circulated power sensor for laser with an approximately Gaussian beam and fiber output	7Z02691
Juno	Compact module to operate one Ophir sensor from your PC USB port	7Z01250
Vega	Hand held color universal power meter	7Z01560

BeamWatch

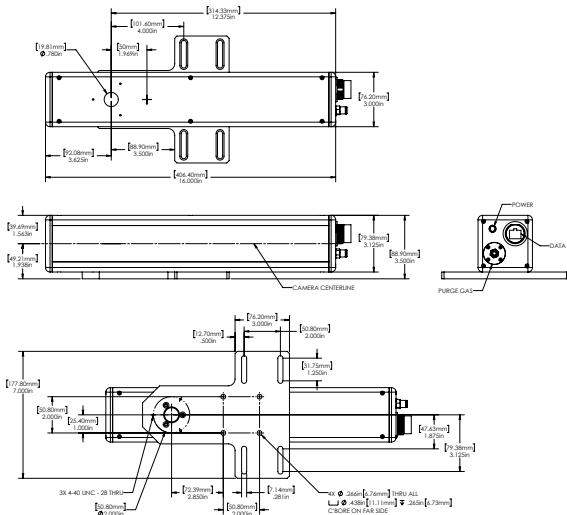

BeamWatch-Plus

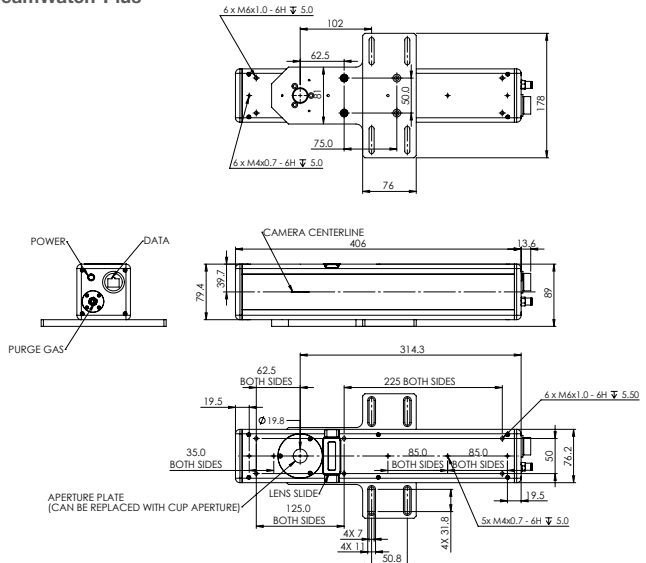

3.8.3 BeamWatch® Integrated - Beam Characterization System for Automated Manufacturing

BeamWatch Integrated is a fully automated laser measurement system designed to measure critical laser beam parameters on industrial production lines.

- Measures all the critical laser beam parameters of the focused beam up to 9999 W power (up to 30 kW on request)
- Measured laser parameters include:
 - Waist (focus spot) width and location
 - Focal shift
 - Centroid
 - M^2 or K
 - Divergence
 - Beam parameter product
 - Rayleigh length
 - Beam tilt angle
 - Absolute power
- Fully automated operation
- Trend analysis with good/bad signal
- Detailed report with time stamp
- Ability to work with different types of welding heads w/o changes to the measurement system
- Industrial interface of choice in addition to GigE: PROFINET, EtherNet/IP and CC-Link
- Rugged for industrial production environment
- Short measurement time for frequent measurements during shift operation
- Two options for single-mode or multi-mode lasers available

Although ever more powerful cutting and welding laser equipment is being used on modern production lines, all too frequently – due either to lack of time or to the complexity – the quality of the laser beam goes unchecked during the production process. Because laser process quality is directly linked to laser quality, this can lead to large batches of defective parts in high-throughput production lines, e.g. in the automotive industry. In addition to the significantly higher risk of loss or safety issues, neglecting to monitor the quality of the laser beam consistently makes it almost impossible to detect the root cause of problems, when they occur.

To address this issue, BeamWatch Integrated was developed. Based on the patented non-contact BeamWatch measurement principle (using Rayleigh scattering), this technology provides for the simultaneous measurements of multiple profiles along the beam caustic at video rates, delivering – in mere fractions of a second – all the beam key parameters according to ISO 13694 and ISO 11146 standards. Real-time performance also allows for detection of dynamic focal shift, while a NIST-traceable power sensor assures absolute power readings. With its shutter and rugged design, BeamWatch Integrated is a compact and self-contained system that can accommodate different types of welding heads. A variety of interfaces makes



it possible to integrate the system into production networks and automated manufacturing lines to facilitate direct transfer of measurement data.

The short measurement times allow the laser beam to be checked automatically during the loading / unloading phase, as frequently as once every produced unit. Additionally, all parameters can be read out using standard interfaces and – as part of the process monitoring – consistently documented for each individual component, as desired. Since they are based on a large amount of measurement data, trend diagrams are highly accurate and can therefore deliver useful insights for predictive maintenance.

Tolerances and limit values can be set up for measured parameters to trigger corrective actions as needed. BeamWatch Integrated operates virtually without maintenance, because contactless measurement exerts no wear on the instrument.

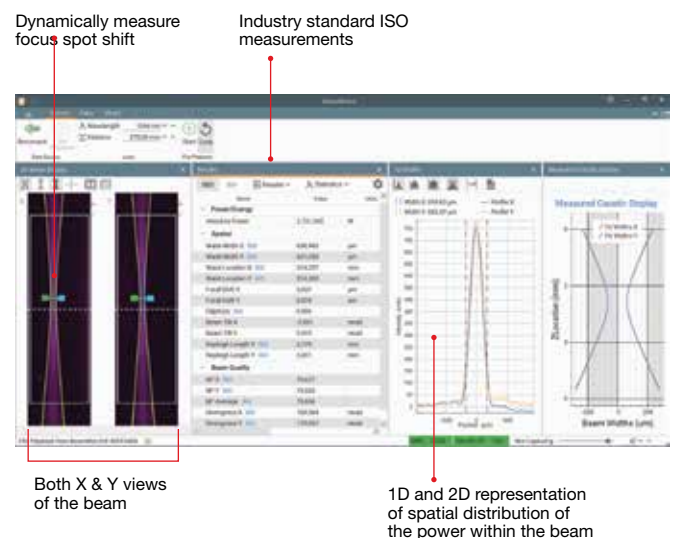

3.8.3.1 Beamwatch Integrated 150

- Automatically measure laser power, caustic and focus shift in real time
- Support multi-mode lasers
- Fully automated operation
- Trend analysis with good/bad signal
- Detailed report with time stamp
- Ability to work with different types of welding heads w/o changes to the measurement system
- Rugged for industrial production environment
- Short measurement time for frequent measurements during shift operation



Specifications

Model	For Waist Size ≥ 155			For Waist Size ≥ 55
	BW-Integrated-150-NIR-155-Profinet	BW-Integrated-150-NIR-155-Ethernet/IP	BW-Integrated-150-NIR-155-CC-Link	BW-Integrated-150-NIR-55-Profinet
Beam Profiling				
Wavelength	980 - 1080 nm			
Minimum Waist size	155 μ m	155 μ m	155 μ m	55 μ m
Waist width accuracy	$\pm 5\%$			
Waist location accuracy	$\pm 125\mu$ within the BeamWatch window			
Camera field of view inside the unit	32.17 mm x 8.55 mm			11 mm x 2.99 mm
Maximum entrance/exit beam diameter	12.5 mm			
Focal shift accuracy	$\pm 50\mu$ m			
BPP accuracy	$\pm 3.5\%$ RMS			
Divergence accuracy	$\pm 3.5\%$ RMS			
M ² accuracy	$\pm 3.5\%$ RMS			
Particulate purge	Clean dry gas (Air, Nitrogen, Argon), ~5-10 L/min, 6 bar			
Power Meter				
Power range	500 W - 9999 W (up to 30 kW on request)			
Maximum power density at power meter ⁽¹⁾	Beam diameter	Max power density		
	< 15 mm	10 kW/cm ²		
	15 - 20 mm	7 kW/cm ²		
	20 - 40 mm	5 kW/cm ²		
40 - 45 mm	4 kW/cm ²			
Power sensor response time	2.7 s max for 9999 W (quicker for less power)			
Backscattered power	< 1 %			
Power noise level	25 W			
Linearity with power	$\pm 2\%$			
Power accuracy	$\pm 5\%$			
Software				
BeamWatch Integrated software	PROFINET	EtherNet/IP	CC-Link	PROFINET
	Webinterface or BeamWatch Software			
Output	OK/Warning/NOK values, CSV, PDF and BeamWatch files			
Calibration Certificates				
Power Sensor	NIST traceable			
Camera	Certification			
General				
Communication	PROFINET & GigE	EtherNet/IP & GigE	CC-Link & GigE	
Distance between focus and power meter	150-175 mm			
Power supply	24 Volts DC, 5 Amps max			
Water cooling ⁽²⁾	Clean non-corrosive water, 8 L/min, 18-30 °C, 6 bar, ~2 bar pressure drop			
Weight	~20 kg			
Dimensions	21.78 in x 12.48 in x 6.78 in			
	553 mm x 317 mm x 172 mm			
Compliance	CE, UKCA, China RoHS			
Ordering information				
Part Number	SP90512	SP90528	SP90537	SP90584

Notes: (1) For circular beam centered within 1/4 of beam diameter. IMPROPERLY CENTERED BEAM CAN CAUSE DAMAGE TO SENSOR. Maximum tilt angle on power sensor ± 5 degrees. For rectangular beam please consult MKS Ophir representative
 (2) Water temperature rate of change $< 1^\circ\text{C}/\text{min}$. The recommended flow rate can be lowered proportionately at lower than full power but should not be below 3 liter/min. The response time will be optimum with the recommended flow rate.

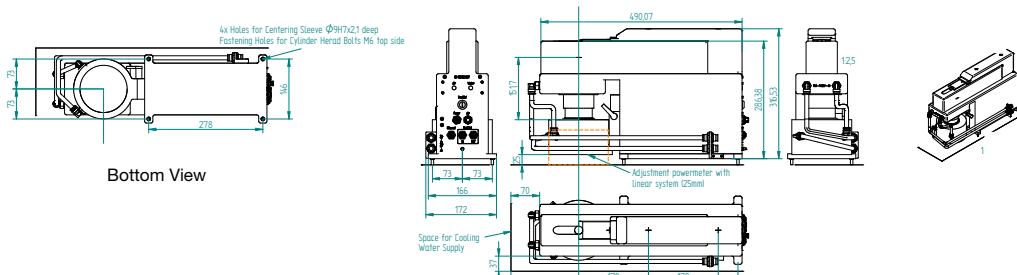

3.8.3.2 Beamwatch Integrated 500

- Automatically measure laser power, caustic and focus shift in real time
- Support single-mode lasers
- Fully automated operation
- Trend analysis with good/bad signal
- Detailed report with time stamp
- Ability to work with different types of welding heads w/o changes to the measurement system
- Rugged for industrial production environment
- Short measurement time for frequent measurements during shift operation



Specifications

Model	BW-Integrated-500-NIR-155-Profinet	BW-Integrated-500-NIR-155-Ethernet/IP	BW-Integrated-500-NIR-155-CC-Link
Beam Profiling			
Wavelength	980 - 1080 nm		
Waist width accuracy	±5 %		
Waist location accuracy	±125 µm within the BeamWatch window		
Camera field of view inside the unit	32.17 mm x 8.55 mm		
Maximum entrance/exit beam diameter	12.5 mm		
Focal shift accuracy	±50 µm		
BPP accuracy	±3.5 % RMS		
Divergence accuracy	±3.5 % RMS		
M ² accuracy	±3.5 % RMS		
Particulate purge	Clean dry gas (Air, Nitrogen, Argon), ~5-10 L/min, 6 bar		
Power Meter			
Power range	500 W - 9999 W (up to 30 kW on request)		
Maximum power density at power meter ⁽¹⁾	Beam diamete	Max power density	
	< 15 mm	10 kW/cm ²	
	15 - 20 mm	7 kW/cm ²	
	20 - 40 mm	5 kW/cm ²	
	40 - 45 mm	4 kW/cm ²	
Power sensor response time	2.7 s max for 9999 W (quicker for less power)		
Backscattered power	< 1 %		
Power noise level	25 W		
Linearity with power	±2 %		
Power accuracy	±5 %		
Software			
BeamWatch Integrated software	PROFINET Webinterface or BeamWatch Software	EtherNet/IP	CC-Link
Output	OK/Warning/NOK values, CSV, PDF and BeamWatch files		
Calibration Certificates			
Power Sensor	NIST traceable		
Camera	Certification		
General			
Communication	PROFINET & GigE	EtherNet/IP & GigE	CC-Link & GigE
Distance between focus and power meter	500 mm		
Power supply	24 Volts DC, 5 Amps max		
Water cooling ⁽²⁾	Clean non-corrosive water, 8 L/min, 18-30 °C, 6 bar, ~2 bar pressure drop		
Weight	~20 kg		
Dimensions	21.78 in x 26.87 in x 6.78 in 553 mm x 682 mm x 172 mm		
Compliance	CE, UKCA, China RoHS		
Ordering information			
Part Number	SP90527	SP90529	SP90538

Notes: (1) For circular beam centered within ¼ of beam diameter. IMPROPERLY CENTERED BEAM CAN CAUSE DAMAGE TO SENSOR. Maximum tilt angle on power sensor ±5 degrees. For rectangular beam please consult MKS Ophir representative
 (2) Water temperature rate of change <1°C/min. The recommended flow rate can be lowered proportionately at lower than full power but should not be below 3 liter/min. The response time will be optimum with the recommended flow rate.

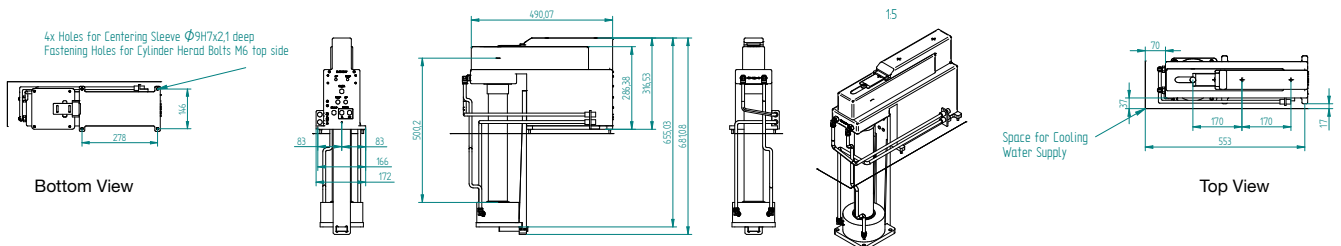

3.9 Additive Manufacturing Systems

Additive manufacturing (AM) has restructured how prototype, developmental and advanced design mechanical components are made. Direct Laser Melting, Selective Laser Sintering or 3D Metal Printing is quickly becoming the standard for designs that could not be fabricated with traditional metal removing techniques. To create consistent, strong structures using laser-based additive manufacturing processes that meet aviation DOD standards or medical device FDA requirements, the metallurgy must be consistent, and a laser beam of known dimension, power density and focal spot location is required. Quality 3D laser printed processes require a laser delivering the correct amount of power, distributed correctly and focused at the correct location. To insure consistent and structurally sound parts these parameters should be directly measured before and after any critical part is made.

As AM systems have gained in popularity for the mass production of metallic parts, the components produced are becoming larger in size while having finer details. This requires increasing AM chambers, having larger powder platforms and longer laser focal lengths. Simultaneously,



they are equipped with more powerful lasers having smaller focal spots.

Ophir instruments designated for AM systems meet the accuracy requirements of modern AM chambers and lasers, allowing accurate measurement of focal spot size and position, laser profile, and power distribution. They measure how those parameters change with time as well, to assist maintenance of quality and repeatability of the manufactured parts.

Model	BeamPeek™	BeamWatch® AM
Wavelengths (nm)	532, 1030-1080	1060-1080
Maximum power (Watt)	1000	1000
Minimum Focal Spot (µm)	34.5	50
Cooling	Passive	Fan
Analysis		
M ² (Caustic)	√	√
Rayleigh length	√	√
Focal Spot location	√	√
Beam Profile	√	√
Power	√	√
Software	BeamPeek Software, BeamGage Pro	BeamWatch
Part Number	SP90609	SP90470

3.9.1 BeamPeek™

Beam Profiling and Power Meter for AM Industry

The BeamPeek laser beam profiler and power meter allows simultaneous beam profiling, focal spot analysis, and power measurement of additive manufacturing (AM) lasers. It integrates both beam profiler, power meter, optical beam sampling system and beam dump. The electronics, beam splitters, and optics, as well as the SP932U CMOS camera and power meter are safely confined in separate chamber. The beam dump is integrated into an easily replaceable tray without the need for active cooling using air or water.

- Focal spot size and position, Laser Beam Profile, and Power
- Multimode and single mode lasers
- Rugged for industrial production environment and metallic powder
- Doesn't require water or air cooling
- Fits AM chambers with 150-800mm focal lengths



Software Features

Features	
Measurements	Beam Diameter (ISO) Z locations X Alignment Y Alignment Total Power (ISO) Average Power Density (ISO) Ellipticity (ISO) Waist Diameter (ISO) Waist Location (ISO) Power Density at Waist (ISO) M ² (ISO) K (ISO) Divergence (ISO) Rayleigh Length (ISO) BPP (Beam Parameter Product)
User Interface	Intuitive access and usability as well as the option to hide controls Flexible Display Environments
2D display	Real-time representation of the intensity distribution within the beam Selectable Color Palettes designed to work with variety of safety eyewear
Caustic Display	Displays beam diameter along the propagation Select a point to display frame results from that plane Displays Danger zone for safe operation
3D Beam Display	3D representation of beam constructed from all saved frames
Calculations	Frame Results (Beam Diameter, Z location, X Alignment, Y Alignment, Total Power, Average Power Density, Ellipticity) Laser Results (Waist Diameter, Waist Location, Power Density at Waist, M ² , Divergence, Rayleigh Length, BPP, K) Supported Beam Diameter Calculations <ul style="list-style-type: none"> • D4σ • % Peak (13.5% clip level) • EPSA (86.5% clip level)
Single Page Report	Setup information Results Caustic Display 3D Beam Display

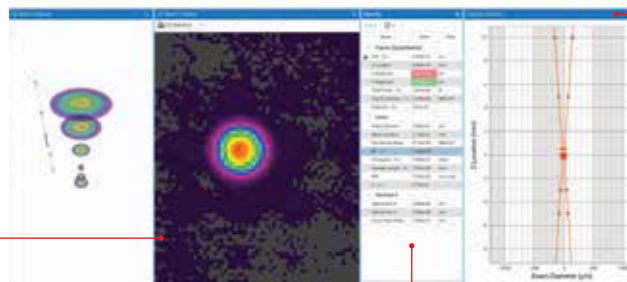

This window displays the 2D or 3D beam profile.

The Caustic Display shows the X and Y beam widths plotted against the Z axis locations.

This window displays quantitative measurements of the laser parameters. These include waist width, beam widths, M², K, power density, divergence angles, Rayleigh range, and other parameters shown.

Specifications

Model	BeamPeek
Beam Profiling, Power Meter and Beam Dump	
Wavelengths	532nm, 1030 - 1080 nm
Spot size (min - max)	34.5µm - 2mm
Maximum power	Multimode: 1000W Single mode: 1000W at 1064nm 700W at 532nm
Minimum power	10W
Measuring rate	24fps
Maximum spot size at entrance	10mm
Maximum incidence angle	0.5°
Operation time	2 min at 1000W
Camera position from bottom plane ⁽¹⁾	Nominal 76.54mm
Accuracy	±3% at 532nm & 1064nm ±5% for 1030nm to 1080nm
Response time	<3s
Cooling	Passive
Software	BeamPeek™ Software ⁽²⁾
Calibration Certificates	
Power sensor	NIST traceable
JUNO USB converter	NIST traceable
Camera position from bottom plane ⁽¹⁾	Test Certificate ±100 µm
General	
Communication and power ⁽³⁾	USB 3.0
Storage temperature	-30° C to 65° C
Storage humidity	95% maximum (non-condensing)
Operating temperature	10° C to 40° C
Weight	~9.5 kg
Dimensions	190mm x 190mm x 175mm
Compliance	CE, UKCA, China RoHS
Ordering Information	
Part Number	SP90609

Notes: (1) Nominal value, may differ from item to item due to assembly and camera tolerances; actual value is on COC, calibration sticker, ± 100µm

(2) BeamPeek can also be used with BeamGage Professional, StarLab, and BeamPeek Tools

(3) Comes with 2m cable, 15m active USB 3.0 cable P/N: 7E11214 available on request as accessory

Accessory Ordering Information

Item	Description	P/N
Beam-Dump Cartridge	Replicable beam dump cartridge for BeamPeek	SP98005

BeamPeek Drawing

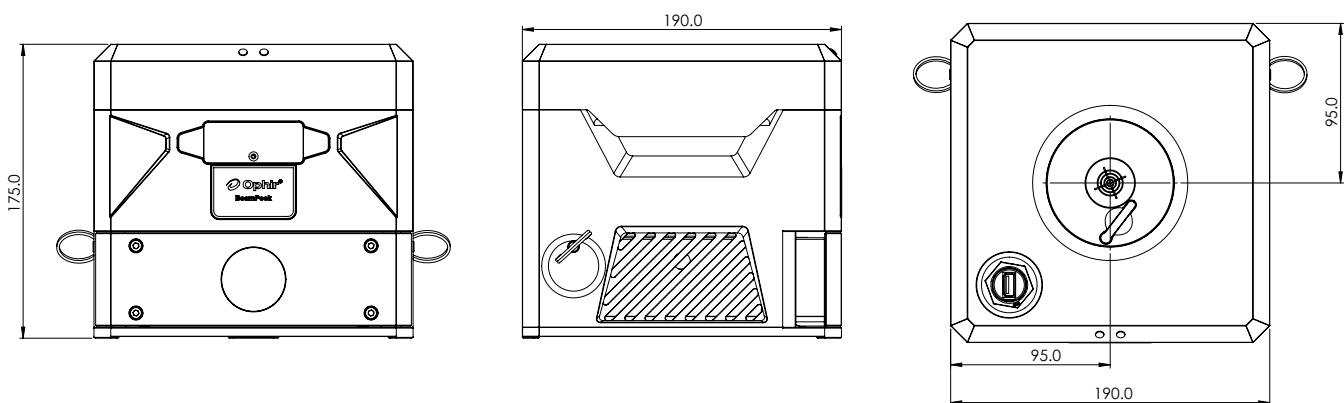

3.9.2 BeamWatch® AM

BeamWatch AM provides simultaneous measurements of multiple profiles along the beam caustic in the camera field-of-view (FOV). Real-time measurements are performed at video rates.

They include:

- Waist (focus spot) width and location
- Focal shift
- Centroid
- M^2 or K
- Divergence
- Beam Parameter Product
- Rayleigh length
- Absolute power
- Tilt angle



Real-time performance also allows for measurement of dynamic focal shift during laser startup. BeamWatch AM measurement technique is based on Rayleigh scattering of laser light by oxygen and nitrogen molecules in the air as the beam propagates through the medium. Measurement of this scattered light provides an equivalent slit-scan of the laser beam in the direction of the observed view. The scattered light is measured using a conventional camera and image capture systems. BeamWatch AM includes a camera for spatial measurements and a NIST-traceable power sensor that will provide a complete analysis of the laser power density profile. The camera is simultaneously, and real-time, viewing the beam caustic including the near/ focus/and far field of the beam. This measurement technique includes Propagation and M^2 measurements adhering to the ISO 11146 standards. In addition, and because all measurements are made in real-time, any focal shift occurring during the critical start up seconds is measured and reported. BeamWatch AM has USB connectivity to Windows personal computers for data acquisition, analysis, and display.

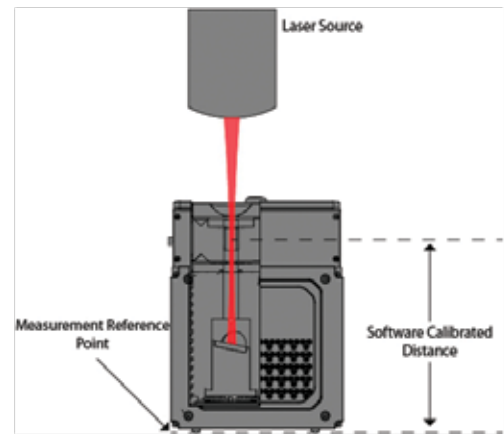

Calibrated beam path for precise focus spot location

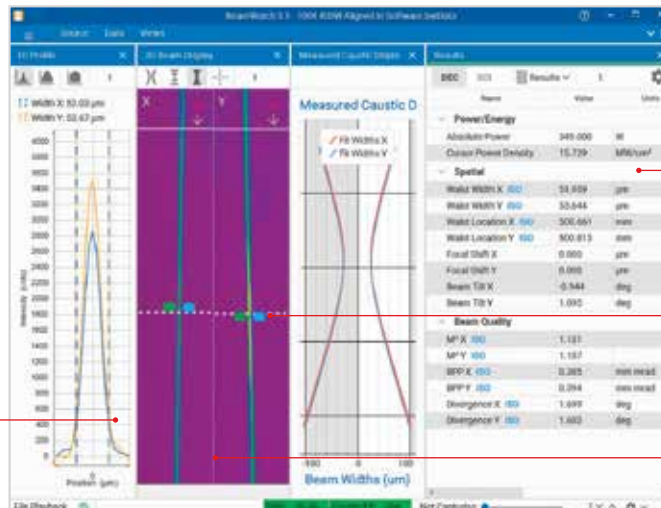

1D and 2D representation of spatial distribution of the power within the beam

Industry standard ISO measurements

Dynamically measure focus spot shift

Both X & Y views of the beam

Specifications

Model	BW-NIR-2-50-AM
Beam Profiling	
Wavelengths	1060-1080 nm
Minimum power density	1.5 Megawatts/cm ²
Minimum focus spot	50 microns
Maximum beam diameter at entrance/exit	6 mm (4.5 mm using the Halo Aperture)
ISO 11146 measurements	Self monitoring; will display ISO next to the measurement
Power Meter/Beam Dump	
Measured power	50 W to 1000 W
Maximum power exposure	1000 W for 2 minutes
Precision	NIST traceable calibration, ±3%
Cool-down time	20 minutes with fan cooling if used to maximum exposure
Software	
BeamWatch AM software	To run on user supplied PC
	Data is saved in ASCII and HDF5 formats
	Print-out of critical measurements and graphics
Calibration Certificates	
Power sensor	NIST traceable
JUNO USB converter	NIST traceable
Camera	Certification
Distance from bottom of unit to focus location	NIST/National Lab traceable
General	
Communication to PC	USB 2.0 & USB 3.0
Power	110 - 220 Volts AC 50/60Hz
Particulate purge	Clean dry gas
Weight	17 lbs
Dimensions	7.03in x 4.96in x 7.16in 178.57mm x 126mm x 181.92mm
Compliance	CE, UKCA, China RoHS
Ordering Information	
Part Number	SP90470
Accessories	
Turning Cu mirror & springs	Replacement mirror SP90611

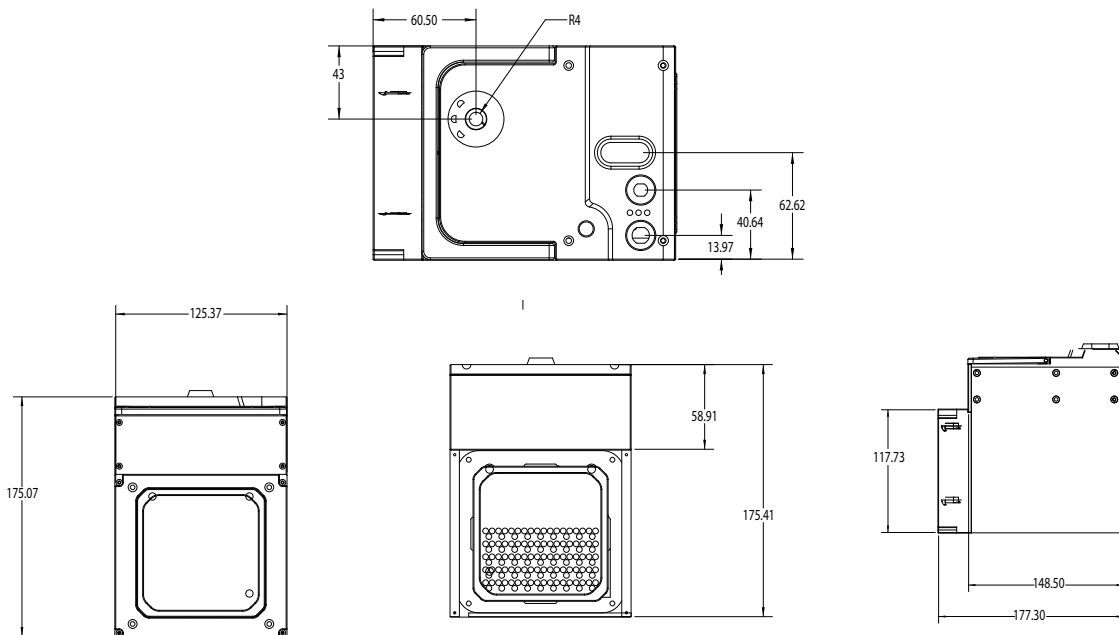

PRODUCT INDEX

Product	P/N	Page
1/4-20 Mount, Photodiode Trigger	SP90434	274
1" FC fiber adapter	7Z08286	40
1" SMA fiber adapter	7Z08285	40
1" to SM1 adapter	7Z08289	40, 145
1st Wedge Beam Splitter (BB)	SPZ17015	264, 272, 273
1st Wedge Beam Splitter (NIR)	SPZ17031	264
1X UV image converter	SPZ17023	272, 273
2" LT- Mount Extension Tube	SP90575	258
2A-BB-9	7Z02767	47
2nd Wedge Beam Splitter (BB)	SPZ17026	264, 266, 273
2nd Wedge Beam Splitter (NIR)	SPZ17032	264
2nd Wedge Beam Splitter Large Aperture (BB)	SPZ17025	264, 273
2.5" to 1" port reducer	7Z08305A	40
3" LT- Mount Extension Tube	SP90574	258
3A	7Z02621	41, 47
3A, Sensor with different cable length	7Z02621C	47
3A-FS	7Z02628	49
3A-IS	7Z02404	35, 41
3A-IS-IRG	7Z02403	35
3A-P	7Z02622	47
3A-PF-12	7Z02720	47
3A-P-FS-12	7Z02687	49
3A-P-QUAD	7Z07935	47, 55, 114
3A-P-THz	7Z02742	49
3A-QUAD	7Z07934	47, 55, 114
3A-UAF	Consult Ophir Representative	150
4mm spacer	SPG01698	269, 273
4X Beam Expander with UV Converter	SPZ17022+SPZ17019	267, 272, 273
4X Reducers to 1.5-12 UNF Adapter	SP90570	273
4X Reducers to C-Mount Adapter	SP90569	273
4X Reducing UV image converter	SPZ17024	272, 273
4X Reimaging beam expander	SPZ17022	266, 267, 273
4X Reimaging beam reducer	SPZ17017	268, 273
5mm spacer	SPG02106	269
6K-W-BB-200x200	7Z02764	90
6X expanding microscope objective	SPZ08257	266, 273
8mm spacer	SPG02067	269, 273
10A-BB-16	7Z07128	51
10A-P	7Z02649	53
10A-BB-16-PPS	7Z07905	51, 55, 114
10K-W /15K-W Scatter shield	7Z08295	101, 121
10K-W Protective Cover	1G01332	102, 121
10K-W/15K-W Scatter Shield Cover	7Z08345	102, 121
10K-W-BB-45	7Z07102	86, 285
10X, Microscope objective	SP90295	275
12A	7Z02638	50
12A-P	7Z02624	50
12X expanding microscope objective	SPZ08259	266, 273

Product	P/N	Page
15(50)A-PF-DIF-18	7Z02740	53
15K-W-BB-45	7Z07133	87
20K-W Protective cover	1G02813	102, 121
20K-W Scatter shield	7Z08355	101, 121
20K-W-BB-55	7Z07149	87
20C-BB-12-SH	7Z07129	64, 151
20C-UAE	Consult Ophir Representative	151
20C-UAS	Consult Ophir Representative	151
20C-UAU	Consult Ophir Representative	151
20mm diameter UV imaging plate	SPF01177	272
20X, Microscope objective	SP90294	275
22X expanding microscope objective	SPZ08260	266, 273
25mm focal length CCTV lens kit	SP90085	269
30(150)A-BB-18	7Z07122	58
30(150)A-HE-17	7Z02722	61
30(150)A-HE-DIF-17	7Z02729	61
30(150)A-LP2-18	7Z02786	58
30(150)A-SV-17	7Z02724	60
30A-BB-18	7Z07124	51
30A-N-18	7Z02695	53
30A-P-17	7Z02693	53
30K-W Scatter Shield Cover	7Z08346	102, 121
30K-W Scatter shield	7Z08293	101, 121
30K-W-BB-74	7Z07136	88, 285
30mm diameter UV imaging plate	SPF01150	272
40X, Microscope objective	SP90293	275
50(150)A-BB-26-PPS	7Z07907	62, 115
50(150)A-BB-26-QUAD	7Z07938	62, 115
50A-PF-DIF-18	7Z02738	53
50mm focal length CCTV lens kit	SP90038	269
50mm X 50mm UV imaging plate	SP90082	272
60X microscope objective	SP90292	275
100C- BB-18-SH	7Z07126	64, 155
100C-UAE	Consult Ophir Representative	153
100C-UAF	Consult Ophir Representative	153
100C-UAU	Consult Ophir Representative	153
120K-W	7Z02691	91, 285
150K-W	7Z07152	91
150C-SH	7N77023	64, 157
150C-UAE	Consult Ophir Representative	155
150C-UAF	Consult Ophir Representative	155
150C-UAU	Consult Ophir Representative	155
150W-SH	771001	64
150W-UAE	Consult Ophir Representative	157
150W-UAF	Consult Ophir Representative	157
150W-UAU	Consult Ophir Representative	157
600W-UAF	Consult Ophir Representative	159
1000W-BB-34	7Z02750	80
1000W-BB-34-QUAD	7Z07936	76, 80, 118
1000W-LP2-34	7Z02774	80

Product	P/N	Page
1000WP-BB-34	7Z02753	80
5000W / 10K-W / 15K-W Protective Housing	7Z08344	100, 121
5000W-BB-50	7Z07111	85, 285
5000W-LP2-50	7Z07135	85
5000WP-LP2-50	7Z02788	85
Ariel	7Z07137	106
ATP-K	PH00128	255
Battery Pack for StarLite and StarBright	7E14008	176, 182
Battery Pack for Vega and Quasar	7E14007A	178, 194
BC20	7Z02481	30
BD10K-W	7Z17205	98, 260
BD5000W-BB-50	7Z17206	98
BDFL1500A-BB-65	7Z17203	98
BDFL500A-BB-50	7Z17200	98
Beam Deflector Assembly for 1064 nm, high damage threshold	SP90284	258
Beam Deflector Assembly for 266 nm, high damage threshold	SP90287	258
Beam Deflector Assembly for 350-1200 nm only	SP90263	258
Beam Deflector Assembly for 355 nm, high damage threshold	SP90286	258
Beam Deflector Assembly for 532 nm, high damage threshold	SP90285	258
Beam Splitter Assembly	7Z17001	140
Beam splitter for 4X reducing UV image converter	SPZ17007	272
Beam splitter for 4X expander	SPZ17027	266, 273
Beam splitter large wedge	SPZ17018	268
Beam-Dump Cartridge	SP98005	291
BeamMic to BGP Upgrade	SP90317	242
BeamMic to BGS Upgrade	SP90316	242
BeamPeek™	SP90609	289, 291
BGP license for BSQ-SP1203	SP90568	281
BGP license for BSQ-SP204S	SP90634	281
BGP license for BSQ-XC130	SP90508	281
BGP-GigE-SP1201	SP90523	232
BGP-GigE-SP1201 (for USA only)	SP90547	232
BGP-GigE-SP1203	SP90524	232
BGP-GigE-SP1203 (for USA only)	SP90548	232
BGP-G-SP504S	SP90618	229, 273
BGP-LBS-300s-BB-CAL-LT665	SP90484	245
BGP-LBS-300s-NIR-CAL-LT665	SP90483	245
BGP-LBS-300s-UV-CAL-LT665	SP90481	245
BGP-LBS-300s-VIS-CAL-LT665	SP90482	245
BGP-USB3-LT665-1550	SP90385	231
BGP-USB3-SP203P	SP90637	231
BGP-USB3-SP204S	SP90648	228
BGP-USB3-SP402S	SP90643	229
BGP-USB3-SP932U	SP90607	228
BGS license for BSQ-SP204S	SP90633	281
BGS-USB3-LT665-1550	SP90384	231
BGS-USB3-SP920s	SP90549	260
BGS-USB3-SP203P	SP90636	231
BGS-USB3-SP204S	SP90647	228
BGS-USB3-SP402S	SP90642	229

Product	P/N	Page
BGS-USB3-SP932U	SP90606	228, 260
BM-USB3-SP203P	SP90638	242
BM-USB3-SP932U	SP90608	242
Bracket for PD10-C, PD10-IR-C, PD10-pJ-C, PD10-IR-pj-C	7Z08275	140
Bracket for PE50-C, PE50BF-C	7Z08270	140
Bracket for PE9-C, PE9-ES-C, PE10-C, PE10BF-C, PE25-C, PE25BF-C	7Z08269	140
BSQ SP1203 license Kit	SP90645	280
BSQ SP300 or SP920 to SP204S upgrade	SP90632	281
BSQ-A	SP90445	280
BSQ-A-SP1203	SP90644	280
BSQ-Lens Kit 266-1550	SP90449	281
BSQ-Lens Kit 650-1700	SP90450	281
BSQ-Lens Kit Extended NIR 400mm	SP90455	281
BSQ-Lens Kit Extended NIR 600mm	SP90485	281
BSQ-Lens Kit UV-XNIR	SP98009	281
BSQ-Lens NIR 400mm	SP90454	281
BSQ-Lens UV 500mm	SP90451	281
BSQ-Lens VIS 400mm	SP90453	281
BSQ-Lens VIS 500mm	SP90452	281
BSQ-Lens NIR 750mm	SP90556	281
BSQ-Lens UV 1000mm	SP90558	281
BSQ-Lens UV 750mm	SP90554	281
BSQ-Lens VIS 1000mm	SP90559	281
BSQ-Lens VIS 750mm	SP90555	281
BSQ-Lens XNIR 750mm	SP90557	281
BSQ-PY-M	SP90410	280
BSQ-SP204S	SP90630	280
BSQ-SP204S-A	SP90631	281
BSQ-UV Reflective Filter	SP90568	281
BT50A-15	7Z17204	57
BT-I	SP90135	263
BT-II	SP90133	263
BT-II-YAG	SP90172	263
BT-I-YAG	SP90173	263
BW-Integrated-150-NIR-155-CC-Link	SP90537	287
BW-Integrated-150-NIR-155-Ethernet/IP	SP90528	287
BW-Integrated-150-NIR-155-Profinet	SP90512	287
BW-Integrated-500-NIR-155-CC-Link	SP90538	288
BW-Integrated-500-NIR-155-Ethernet/IP	SP90529	288
BW-Integrated-500-NIR-155-Profinet	SP90527	288
BW-NIR-130	SP90623	285
BW-NIR-2-50-AM	SP90470	289, 293
BW-PLUS-45	SP90613	285
Carrying Case for Vega, Nova II, Nova, StarLite, StarBright	1J02079	176, 178, 180, 182 184, 185
Centauri Dual Channel	7Z01701	168, 174
Centauri Dual Channel Activation Code	7Z11056	174, 185
Centauri Single Channel	7Z01700	168, 174
C-Mount, Photodiode Trigger	SP90437	274
C-NFP Assy	SP90291	275
Comet 10K	7Z02705	110

Product	P/N	Page
Comet 10K-HD	7Z02706	110
Comet 1K	7Z02702	110
Cup aperture	SP90476	285
Damage Threshold Test Plates-BB type	7E06031C	141
Damage Threshold Test Plates-BF type	7E06031D	141
Damage Threshold Test Plates-Metallic type	7E06031A	141
DPFSA	PH00053	265
EA-1	7Z01240	169, 190
EA-1 Ethernet Cable	7E01192	185, 190
EtherNet/IP Cable, M12-D to RJ45, 3m	7E11211	94, 104
F100A-PF-DIF-33	7Z02744	72
F150(200)A-CM-16	7Z07107	60
F150A-BB-26	7Z07120	72
F150A-BB-26-PPS	7Z07906	62, 72, 116
F50A-BB-18	7Z07121	72
F80(120)A-CM-17	7Z07103	60
FC, FC/APC Adapter for PD300-IRG	7Z08216	33
FC, FC/APC fiber adapter	7Z08229	33, 120, 140, 145
Female SM1 to SM1 Adapter for PD300R series	1G02260	33
Fiber adapter mounting bracket for 30A-BB-18, 30A-N-18, 30(150)A-BB-18, 30(150)A-LP2-18, F50A-BB-18	7Z08211	120
Fiber adapter mounting bracket for 30A-P-17, 30(150)A-SV-17, 30(150)A-HE-17	7Z08230	120
Fiber adapter mounting bracket for 3A-IS, 3A-IS-IRG	7Z08213	33
Fiber adapter mounting bracket for 50(150)A-BB-26, 50(150)A-BB-26-PPS, F150A-BB-26, F150A-BB-26-PPS, 50(150)A-BB-26-QUAD	7Z08210	120
Fiber adapter mounting bracket for FL250A-BB-35, FL250A-LP2-35, L50(150)A-BB-35, L50(150)A-LP2-35, L50(150)A-PF-35	7Z08265	120
Fiber adapter mounting bracket for FL400A-BB-50, FL250A-BB-50, FL400A-LP2-50, FL250A-BB-50-PPS	7Z08212	120
Fiber adapter mounting bracket for IS-1-2W	7Z08331	33
Fiber adapter mounting bracket for L40(250)A-BB-50, L40(250)A-LP2-50, L50(250)A-BB-50	7Z08238	120
Fiber adapter mounting bracket for PD300R series and FPS-1	1G02259	33
Fiber adapter mounting bracket SMA type	1G01236A	33, 120, 140, 145
Filter for 355nm	SPZ08246	256
FL1100A-BB-65	7Z02761	75
FL1100A-BB-65, Sensor with different cable length	7Z02761A	75
FL1100A-LP2-65	7Z02784	75
FL250A-BB-35	7Z02728	73
FL250A-BB-50	7Z07116	74
FL250A-BB-50, Sensor with different cable length	7Z07116B	74
FL250A-BB-50-PPS	7Z07902	76, 118
FL250A-LP2-35	7Z02777	73
FL250A-LP2-DIF-33	7Z02787	73
FL400A-BB-50	7Z02734	74
FL400A-LP2-50	7Z02778	74
FL600A-BB-65	7Z02762	75
FL600A-LP2-65	7Z02779	75
Flange attachment	7Z08306	40
FPD (except FPS-1) to IS6 Adapter	7Z08350	40, 145
FPD-IG-175	7Z02509	144
FPD-IG-25	7Z02508	144
FPD-UV-3000	7Z02506	144

Product	P/N	Page
FPD-VIS-300	7Z02507	144
FPE80BF-DIF-C	7Z02950	138
FPS-1 Fast Photodetector	7Z02505	144
FSA-100Y	SP90188	259
FSA-150Y	SP90190	259
FSA-50Y	SP90187	259
FSA-BB-SP932U	SP90617	245
FSA-HP-NIR-SP932U	SP90603	245
FSA-NIR-SP932U	SP90616	245
FSA-UV-SP932U	SP90614	245
FSA-VIS-SP932U	SP90615	245
Heat Sink	7Z08267	140
Heavy Duty Stand for 10K-W and 15K-W	7Z08330	101, 121
Helios Pro - Profinet	7Z07146	103
Helios Pro - Profinet, Diffuser	7Z07147	103
Helios Pro - EtherNet/IP	7Z07142	103
Helios Pro - EtherNet/IP, Diffuser	7Z07143	103
Helios Pro - EtherNet/IP-M	7Z07140	103
Helios Pro - EtherNet/IP-M, Diffuser	7Z07139	103
Helios Pro - EtherCAT	7Z07144	103
Helios Pro - EtherCAT, Diffuser	7Z07145	103
Interlock cable, M8 female 3-pin to flying leads, 1.5m	7E01513	94
IPM-10KW	7Z07106	94, 96, 97
IPM-COM-EtherNet/IP-M	7Z08405	94, 96, 97
IPM-COM-Profinet	7Z08404	94, 96, 97
IPM-SHUTTER10	7Z08409	94, 96, 97
IPM-SHUTTER10 Window replacement kit	7Z08411	94, 96, 97
IS-1" Port cover	7Z08282A	40
IS-1" Port plug	7Z08280A	40
IS1.5-IRG-FPD-800	7Z02493	37
IS1.5-VIS-FPD-800	7Z02491	36
IS-1-2W	7Z02484	35
IS-2.5" Port cover	7Z08281A	40
IS-2.5" Port plug	7Z08283A	40
IS6-C for collimated beams	7Z02474	38
IS6-C-IR	7Z02476	38
IS6-C-UV	7Z02472	38
IS6-C-UV-2.5"	7Z02485	38
IS6-C-VIS	7Z02470	38
IS6-D for divergent beams	7Z02487	38
IS6-D-IR	7Z02490	39
IS6-D-IR-170	7Z02486	39
IS6-D-UV	7Z02489	39
IS6-D-VIS	7Z02488	39
Juno	7Z01250	169, 187, 285
Juno+	7Z01252	169, 188
Juno-RS	7Z01254	169, 189
Juno-RS Analog Output Cable	7E01541	185, 189
Juno-RS Power Supply/Charger	7E05093	185, 189
Juno-RS RS232 Output Cable	7E11216	185, 189

Product	P/N	Page
L100(500)A-PF-120	7Z02765	83
L1500W-BB-50	7Z02752	82
L1500W-LP2-50	7Z02772	82
L150C-UAF	Consult Ophir Representative	159
L2000W-BB-120	7Z02751	83
L2000W-PF-120	7Z02792	83
L250W-BB-50	7Z07125	79
L250W-BB-50, Sensor with different cable length	7Z07125B	79
L250W-UAF	Consult Ophir Representative	159
L300W-LP2-50	7Z02776	79
L300W-UAF	Consult Ophir Representative	159
L30A-BB-26-10MM	7Z07130	51
L30A-EX-10MM	7Z02686	51
L30C- SH	773434	64, 151
L30C-LP2-26-SH	7Z02775	64, 108, 151
L30C-UAE	Consult Ophir Representative	151
L30C-UAF	Consult Ophir Representative	151
L30C-UAU	Consult Ophir Representative	151
L40(150)A-IPL	7Z02771	70
L40(200)A-EX-50	7Z02795	66
L40(250)A-BB-50	7Z07110	66
L40(250)A-BB-50, Sensor with different cable length	7Z07110D	66
L40(250)A-LP2-50	7Z02794	66, 108
L40(500)A-LP2-DIF-35	7Z02797	66, 108
L50(150)A-BB-35	7Z07118	58
L50(150)A-BB-35, Sensor with different cable length	7Z07118D	58
L50(150)A-LP2-35	7Z02785	58
L50(150)A-PF-35	7Z02737	58
L50(250)A-BB-50	7Z07109	68
L50(300)A-BB-65	7Z07127	68
L50(300)A-IPL	7Z02780	70
L50(300)A-LP2-65	7Z02782	68, 70
L50(300)A-PF-65	7Z02743	68
Large C-mount Wedge Splitter	SP90273	258
LBS-100	SP90061	262
LBS-100 filter set	SP90141	262
LBS-100 IR 0.5	SP90058	262
LBS-100 IR 5.0	SP90059	262
LBS-100 to 4X beam reducer adaptor	SPZ17029	262, 268, 273
LBS-100 to SM2 Adaptor	SP98001	229, 262, 273
LBS-100 YAG	SP90057	262
LBS-100 -YAG filter set	SP90142	262
LBS-300HP-NIR	SP90540	260
LBS-300s-BB	SP90467	242, 258
LBS-300s-NIR	SP90466	258
LBS-300s-UV	SP90464	258
LBS-300s-VIS	SP90465	258
LBS-400 C-Mount Adapter	SP90352	261, 273
LBS-400 to Pyrocam™ Adaptor	SP90510	261, 273
LBS-400 to SM2 Adaptor	SP98000	261, 273

Product	P/N	Page
LBS-400 to WB-I Adaptor	SP90572	261, 273
LBS-400-IR	SP90349	261
LBS-400-NIR	SP90354	261
LBS-400-UV	SP90351	261
Locking Ethernet Cable	SP90394	285
LT to External C-Mount Adapter	SP90576	258
LT to Internal C-Mount Adapter	SP90577	258
M20x1 To Internal C-Mount Adapter	SP90567	273
M6 X 1.0 Mount, Photodiode Trigger	SP90435	274
Metric Water Fitting 1/4"NPT to 12mm O.D. tubing	7Z08352	102, 121
Metric Water Fitting 1/8"NPT to 10mm O.D. tubing	7Z08353	102, 121
N Polarity Power Supply/Charger AC/DC 12V 2A N-2.1x5.5	7E05029	121, 141, 174, 178, 180, 184, 185, 190, 191, 192
ND1 nom. x10 attenuator	7Z08200	145
ND1 stackable filter (red housing)	SPZ08234	254
ND2 nom. x50 attenuator	7Z08201	143
ND2 stackable filter (black housing)	SPZ08235	254
ND3 stackable filter (green housing)	SPZ08253	254
Nova	7Z01500	168, 184
Nova Battery Pack	7E14005A	184
Nova II	7Z01550	168, 180
Nova PE-C adaptor	7Z08272	141, 184
Nova RS232 Assembly - 2m cable	7Y78105	184, 185, 198
Nova RS232 Assembly- 5m cable	7Y71052	184, 185
Nova RS232 Assembly - 8m cable	7Y71051	184, 185
NS2s-Ge/3.5/1.8-PRO	PH00467	252
NS2s-Ge/3.5/1.8-STD	PH00459	252
NS2s-Ge/9/5-PRO	PH00468	252
NS2s-Ge/9/5-STD	PH00460	252, 260
NS2s-Pyro/9/5-PRO	PH00470	252
NS2s-Pyro/9/5-STD	PH00462	252
NS2s-Si/3.5/1.8-PRO	PH00464	252
NS2s-Si/3.5/1.8-STD	PH00456	252
NS2s-Si/9/5-PRO	PH00465	252
NS2s-Si/9/5-STD	PH00457	252
NSv2 STD to NSv2 PRO Upgrade	PH00417	252
P Polarity Power Supply/Charger 12V 2A P-1.35x3.5	7E05047	121, 176, 182, 185
PD10-C	7Z02944	126
PD10-C, Sensor with different cable length	7Z02944C	126
PD10-IR-C	7Z02955	127
PD10-IR-pJ-C	7Z02946	127
PD10-pJ-C	7Z02945	126
PD300	7Z02410	25
PD300 F.O. Adapter FC, FC/APC type	7Z02213	33
PD300 F.O. Adapter SC type	7Z08221	33
PD300 F.O. Adapter SMA type	7Z02212	33
PD300 F.O. Adapter ST type	7Z02210	33
PD300-1W	7Z02411A	25
PD300-3W	7Z02426	25

Product	P/N	Page
PD300-BB	7Z02405	30
PD300-BB-50mW	7Z02440	30
PD300-CDRH-3.5mm	7Z08336	33
PD300-CDRH-7mm	7Z02418	33
PD300-CIE	7Z02406	30
PD300-IR	7Z02412	27
PD300-IRG	7Z02495	27
PD300-MS	7Z02482	29
PD300R	7Z02436	28
PD300R-3W	7Z02437	28
PD300R-CDRH-7mm	7Z08347	33
PD300R-IR	7Z02439	28
PD300RM-8W	7Z02480	43
PD300RM-UV	7Z02479	43
PD300RM-UVA	7Z02492	43
PD300R-UV	7Z02438	28, 41
PD300R-UV, Sensor with different cable length	7Z02438C	28
PD300-TP	7Z02424	25
PD300-UAS	Consult Ophir Representative	150
PD300-UV	7Z02413	27, 41
PD300-UV-193	7Z02413A	27
PE XX-C-RS232	Consult Ophir Representative	165
PE100BF-DIF-C	7Z02942	136
PE10BF-C	7Z02938	129
PE10BF-C, Sensor with different cable length	7Z02938C	129
PE10-C	7Z02932	129
PE10-C-RE	Consult Ophir Representative	163
PE25BF-C	7Z02935	130
PE25BF-DIF-C	7Z02941	132
PE25-C	7Z02937	130
PE25-C, Sensor with different cable length	7Z02937C	130
PE50BB-DIF-C	7Z02947	133
PE50BB-DIF-C, Sensor with different cable length	7Z02947B	133
PE50BF-C	7Z02934	131
PE50BF-DIF-C	7Z02940	133
PE50BF-DIFH2-C	7Z02959	134
PE50BF-UV-DIFH-C	7Z02961	134
PE50-C	7Z02936	131
PE50-DIF-C	7Z02939	132
PE50-DIF-C, Sensor with different cable length	7Z02939C	132
PE50-DIF-ER-C	7Z02948	136
PE50-DIFH2-C	7Z02958	134
PE50-UV-DIFH-C	7Z02960	134
PE80BF-DIF-C	7Z02954	138
PE9-C	7Z02933	128
PE9-ES-C	7Z02949	128
PE-C to PE size Adaptor	7Z08273	141
PE-C-RE	Consult Ophir Representative	165
PFSA	PH00052	265
Photodiode Trigger Cable for SP300, 6ft	SP90430	274

Product	P/N	Page
Photodiode Trigger Cable for SP907, SP932U, 6ft	SP90431	274
Photodiode Trigger Cable to BNC for SP920G, SP504S, L11059, Xeva, Pyrocam III, 6ft	SP90433	274
Photodiode Trigger Cable to SMA for LT665, Pyrocam™ IIIHR & IV, SP1201, SP1203, 6ft	SP90432	274
Photodiode Trigger, InGaAs, 1800	SP90409	274
Photodiode Trigger, Si, 1100	SP90408	228, 274
Power Cable, AIDA female, 4-pin, to flying leads, 5m	7Z10458A	97
Power cable, M12 female 5-pin to flying leads, 1.5m	7E01519	94
Power Cable, Mini 7/8" female, 4-pin, to flying leads, 2m	7E01535	97
Profinet Cable, RJ45 AIDA to RJ45, 5m	7E01298	97
Pulsar USB Cable	7E01202	185, 191
Pulsar-1	7Z01203	169, 191
Pulsar-2	7Z01202	169, 191
Pulsar-4	7Z01201	169, 191
PY-III-HR-C-A-PRO	SP90405	237, 273
PY-III-HR-C-MIR-PRO	SP90415	237, 273
PY-III-HR-W-BaF2-Uncoated	SP90373	238
PY-III-HR-W-BK7-1.064	SP90365	238
PY-III-HR-W-GE-10.6	SP90369	238
PY-III-HR-W-GE-3-5.5	SP90368	238
PY-III-HR-W-GE-8-12	SP90370	238
PY-III-HR-W-POLY-THZ	SP90374	238
PY-III-HR-W-SI-1.05-2.5	SP90366	238
PY-III-HR-W-SI-2.5-4	SP90367	238
PY-III-HR-W-ZNSE-10.2µm & 10.6µm	SP90412	238
PY-III-HR-W-ZNSE-10.6	SP90371	238
PY-III-HR-W-ZNSE-2-5	SP90372	238
PY-IV-C-A-PRO	SP90404	237, 273
PY-IV-C-MIR-PRO	SP90414	237, 273
PY-IV-W -ZNSE-2-5	SP90308	238
PY-IV-W-BK7-1.064	SP90301	238
PY-IV-W-GE-10.6	SP90305	238
PY-IV-W-GE-3-5.5	SP90304	238
PY-IV-W-GE-8-12	SP90306	238
PY-IV-W-POLY-THZ	SP90309	238
PY-IV-W-SI-1.05-2.5	SP90302	238
PY-IV-W-SI-2.5-4	SP90303	238
PY-IV-W-ZNSE-10.6	SP90307	238
PY-IV-W-ZNSE-Uncoated	SP90336	238
Pyrocam to Internal C-Mount Adapter	SP90573	273
QBH-L-Fiber Adapter	7Z08348	99, 121
QBH-S-Fiber Adapter	7Z08349	99, 121
Quasar Bluetooth Interface	7Z01300	169, 192
RM9 sensor	7Z02952	45
RM9 sensor and RMC1 Chopper	7Y70669	45
RM9-PD sensor	7Z02953	45
RM9-PD sensor and RMC1 Chopper	7Y70672	45
Rotation Mount	SP90346	285
RS232 cable for Centauri & StarBright	7E01213	172, 174, 185
RS232 Cable for Vega and Nova II	7E01206	178, 180, 185, 198

Product	P/N	Page
RS232 cable, M12 male 5-pin to D9 female, 1.8m	7Z10532	94
SC fiber adapter	7Z08227	33, 120, 140, 145
Scope Adapter	7Z11012	140
Set of aperture masks	7Z08307	40
SH to BNC Adapter	7Z11010	121
SMA fiber Adapter for PD300-IRG	7Z08222	33
SP1201 Kit	SP90535	232
SP1203 Kit	SP90536	232
Spacer assembly set for objectives	SPZ08261	266
ST fiber adapter	7Z08226	33, 120, 140, 145
Standard Analog Output Connector	7E02008	174,176,178, 180, 182, 184, 185, 188
StarBright	7Z01580	168, 176
StarLite	7Z01565	168,182
StarLite USB activation code	7Z11049	182, 185
Swivel stand for BC20 sensor	1Z09004	30
Thru Hole Mount, Photodiode Trigger	SP90436	274
Turning Cu mirror & Springs	SP90611	293
USB Cable for Centauri, Starlite & StarBright	7E01279	174, 176, 182, 185
USB Cable for Juno and EA1	7E01217	185, 187, 188, 190
USB Cable for Vega and Nova II	7E01205	178, 180, 185
UV converter assembly for 4X beam expander	SPZ17019	267, 272, 273
UV ND Filters	SP90228	256
Vega	7Z01560	168, 178, 285
Water Flow Meter cable, M8 male 6-pin to flying leads, 1.5m	7E01536	94
Wide Beam Imager SWIR	SP90605	271, 273
Wide Beam Imager VIS	SP90612	271, 273

PART NUMBER INDEX

P/N	Page	P/N	Page	P/N	Page	P/N	Page
771001	64	7Z01202	169, 191	7Z02488	39	7Z02764	90
773434	64, 153	7Z01203	169, 191	7Z02489	39	7Z02765	83
1G01236A	33, 120, 140, 145	7Z01240	169, 190	7Z02490	39	7Z02767	47
1G01332	102, 121	7Z01250	169, 187, 285	7Z02491	36	7Z02771	70
1G02259	33	7Z01252	169, 188	7Z02492	43	7Z02772	82
1G02260	33	7Z01254	169, 189	7Z02493	37	7Z02773	85
1G02813	102, 121	7Z01300	169, 192	7Z02495	27	7Z02774	80
1J02079	176, 178, 180, 182, 186, 185	7Z01500	169, 184	7Z02505	141	7Z02775	64, 108, 153
1Z09004	30	7Z01550	168, 180	7Z02506	141	7Z02776	79
7E01121	185	7Z01560	168, 178, 285	7Z02507	141	7Z02777	73
7E01192	185, 190	7Z01565	168, 182	7Z02508	141	7Z02778	74
7E01202	185, 191	7Z01580	168, 176	7Z02509	141	7Z02779	75
7E01205	178, 180, 185	7Z01700	168, 174	7Z02621	41, 47	7Z02780	70
7E01206	178, 180, 185, 198	7Z01701	168, 174	7Z02621C	47	7Z02782	68, 70
7E01213	174, 176, 185	7Z02210	33	7Z02622	47	7Z02784	75
7E01217	185, 187, 188, 190	7Z02212	33	7Z02624	50	7Z02785	58
7E01279	174, 176, 182, 185	7Z02213	33	7Z02628	49	7Z02786	58
7E01298	97	7Z02403	35	7Z02638	50	7Z02787	73
7E01513	94	7Z02404	35, 41	7Z02649	53	7Z02788	85
7E01519	94	7Z02405	30	7Z02686	51	7Z02792	83
7E01535	97	7Z02406	30	7Z02687	49	7Z02794	66, 108
7E01536	94	7Z02410	25	7Z02691	91, 285	7Z02795	66
7E01541	185, 189	7Z02411A	25	7Z02693	53	7Z02797	66, 108
7E02008	174, 176, 178, 180, 182, 184, 185, 188	7Z02412	27	7Z02695	53	7Z02932	129
7E05029	121, 141, 174, 178, 180, 184, 185, 190, 191, 192	7Z02413	27, 41	7Z02702	110	7Z02933	128
7E05047	121, 176, 182, 185	7Z02413A	27	7Z02705	110	7Z02934	131
7E05093	185, 189	7Z02418	33	7Z02706	110	7Z02935	130
7E06031A	141	7Z02424	25	7Z02720	47	7Z02936	131
7E06031C	141	7Z02426	25	7Z02722	61	7Z02937	130
7E06031D	141	7Z02436	28	7Z02724	60	7Z02937C	130
7E11211	97, 104	7Z02437	28	7Z02728	73	7Z02938	129
7E11216	185, 189	7Z02438	28, 41	7Z02729	61	7Z02938C	129
7E14005A	184	7Z02438C	28	7Z02734	74	7Z02939	132
7E14007A	178, 192	7Z02439	28	7Z02737	58	7Z02939C	132
7E14008	176, 182	7Z02440	30	7Z02738	53	7Z02940	133
7N77023	64, 157	7Z02470	38	7Z02740	53	7Z02941	132
7Y70669	45	7Z02472	38	7Z02742	49	7Z02942	136
7Y70672	45	7Z02474	38	7Z02743	68	7Z02944	126
7Y71051	184, 185	7Z02476	38	7Z02744	72	7Z02944C	126
7Y71052	184, 185	7Z02479	43	7Z02750	80	7Z02945	126
7Y78105	184, 185, 198	7Z02480	43	7Z02751	83	7Z02946	127
7Y78300	185	7Z02481	30	7Z02752	82	7Z02947	133
7Z01201	169, 191	7Z02482	29	7Z02753	80	7Z02947B	133
		7Z02484	35	7Z02754	85, 285	7Z02948	136
		7Z02485	38	7Z02761	75	7Z02949	128
		7Z02486	39	7Z02761A	75	7Z02950	138
		7Z02487	38	7Z02762	75	7Z02952	45

P/N	Page	P/N	Page	P/N	Page	P/N	Page
7Z02953	45	7Z08200	145	7Z08411	94, 96, 97	SP90286	258
7Z02954	138	7Z08201	145	7Z10458A	97	SP90287	258
7Z02955	127	7Z08210	120	7Z10532	94	SP90291	275
7Z02958	134	7Z08211	120	7Z11004	185	SP90292	275
7Z02959	134	7Z08212	120	7Z11010	121	SP90293	275
7Z02960	134	7Z08213	33	7Z11012	140	SP90294	275
7Z02961	134	7Z08216	33	7Z11049	182, 185	SP90295	275
7Z07102	86	7Z08221	33	7Z11056	174, 185	SP90301	238
7Z07103	60	7Z08222	33	7Z17001	140	SP90302	238
7Z07106	94, 96, 97	7Z08226	33, 120, 140, 145	7Z17200	98	SP90303	238
7Z07107	60	7Z08227	33, 120, 140, 145	7Z17201	98	SP90304	238
7Z07109	68	7Z08229	33, 120, 140, 145	7Z17203	98	SP90305	238
7Z07110	66	7Z08230	120	7Z17204	57	SP90306	238
7Z07110D	66	7Z08238	120	7Z17205	98, 260	SP90307	238
7Z07116	74	7Z08265	120	PH00052	265	SP90308	238
7Z07116B	74	7Z08267	140	PH00053	265	SP90309	238
7Z07118	58	7Z08269	140	PH00128	255	SP90316	242
7Z07118D	58	7Z08270	140	PH00417	252	SP90317	242
7Z07120	72	7Z08272	141, 184	PH00456	252	SP90336	238
7Z07121	72	7Z08273	141	PH00457	252	SP90346	285
7Z07122	58	7Z08275	140	PH00459	252	SP90349	261
7Z07124	51	7Z08280A	40	PH00460	252, 260	SP90351	261
7Z07125	79	7Z08281A	40	PH00462	252	SP90352	261, 273
7Z07125B	79	7Z08282A	40	PH00464	252	SP90354	261
7Z07126	64, 155	7Z08283A	40	PH00465	252	SP90365	238
7Z07127	68	7Z08285	40	PH00467	252	SP90366	238
7Z07128	51	7Z08286	40	PH00468	252	SP90367	238
7Z07129	64, 151	7Z08289	40, 145	PH00470	252	SP90368	238
7Z07130	51	7Z08293	101, 121	SP90038	269	SP90369	238
7Z07131	87, 101, 102, 121	7Z08295	101, 121	SP90057	262	SP90370	238
7Z07133	87	7Z08305A	40	SP90058	262	SP90371	238
7Z07136	88, 285	7Z08306	40	SP90059	262	SP90372	238
7Z07137	106	7Z08307	40	SP90061	262	SP90373	238
7Z07139	103	7Z08330	101, 121	SP90082	272	SP90374	238
7Z07140	103	7Z08331	33	SP90085	269	SP90384	231
7Z07142	103	7Z08336	33	SP90133	263	SP90385	231
7Z07143	103	7Z08344	100, 121	SP90135	263	SP90394	285
7Z07144	103	7Z08345	102, 121	SP90141	262	SP90404	237, 273
7Z07145	103	7Z08346	102, 121	SP90142	262	SP90405	237, 273
7Z07146	103	7Z08347	33	SP90172	263	SP90408	228, 229, 242, 245, 274
7Z07147	103	7Z08348	99, 121	SP90173	263	SP90409	231, 232, 237, 274
7Z07902	76, 118	7Z08349	99, 121	SP90187	259	SP90410	280
7Z07905	51, 55, 114	7Z08350	40, 145	SP90188	259	SP90412	238
7Z07906	62, 72, 116	7Z08352	102, 121	SP90190	259	SP90414	237, 273
7Z07907	62, 116	7Z08353	102, 121	SP90228	256	SP90415	237, 273
7Z07934	47, 55, 114	7Z08355	101, 121	SP90263	258	SP90430	274
7Z07935	47, 55, 114	7Z08404	94, 96, 97	SP90273	258	SP90431	274
7Z07936	80, 76, 118	7Z08405	94, 96, 97	SP90284	258	SP90432	274
7Z07938	62, 116	7Z08409	94, 96, 97	SP90285	258		

P/N	Page	P/N	Page	P/N	Page
SP90433	274	SP90570	273	SPZ08257	266, 273
SP90434	274	SP90572	261, 273	SPZ08259	266, 273
SP90435	274	SP90573	273	SPZ08260	266, 273
SP90436	274	SP90574	258	SPZ08261	266
SP90437	274	SP90575	258	SPZ17007	272
SP90445	280	SP90576	258	SPZ17015	264, 272, 273
SP90449	281	SP90577	258	SPZ17017	268, 273
SP90450	281	SP90603	245	SPZ17018	268
SP90451	281	SP90605	271, 273	SPZ17019	267, 272, 273
SP90452	281	SP90606	228, 260	SPZ17022	266, 267, 273
SP90453	281	SP90607	228	SPZ17022 + SPZ17019	267, 272, 273
SP90454	281	SP90608	242	SPZ17023	272, 273
SP90455	281	SP90609	289, 291	SPZ17024	272, 273
SP90464	258	SP90611	293	SPZ17025	264, 273
SP90465	258	SP90612	271, 273	SPZ17026	264, 266, 273
SP90466	258	SP90613	285	SPZ17027	266, 273
SP90467	242, 258	SP90614	245	SPZ17029	262, 268, 273
SP90470	289, 293	SP90615	245	SPZ17031	264
SP90476	285	SP90616	245	SPZ17032	264
SP90481	245	SP90617	245		
SP90482	245	SP90618	229, 273		
SP90483	245	SP90623	285		
SP90484	245	SP90630	280		
SP90485	281	SP90631	281		
SP90508	281	SP90632	281		
SP90510	261, 273	SP90633	281		
SP90512	287	SP90634	281		
SP90523	232	SP90636	231		
SP90524	232	SP90637	231		
SP90527	288	SP90638	242		
SP90528	287	SP90642	229		
SP90529	288	SP90643	229		
SP90535	232	SP90644	280		
SP90536	232	SP90645	280		
SP90537	287	SP90647	228		
SP90538	288	SP90648	228		
SP90540	260	SP98000	229, 261, 273		
SP90547	232	SP98001	229, 262, 273		
SP90548	232	SP98005	291		
SP90549	260	SP98009	281		
SP90554	281	SPF01150	272		
SP90555	281	SPF01177	272		
SP90556	281	SPG01698	269, 273		
SP90557	281	SPG02067	269, 273		
SP90558	281	SPG02106	269		
SP90559	281	SPZ08234	254		
SP90567	273	SPZ08235	254		
SP90568	281	SPZ08246	256		
SP90569	273	SPZ08253	254		

OPHIR PHOTONICS SITES

Country	Company	Telephone	E-mail
USA	Newport Corporation, Ophir USA	435-753-3729	sales.ophir.usa@mksinst.com
Japan	Ophir Japan Ltd.	81-3-3556-2781	oj.info@mksinst.com
Israel	Ophir Optronics Ltd.	972-2-5487460	eli.israel@mksinst.com
Germany	Ophir Spiricon Europe	49-6151-708-0	ose-sales@mksinst.com

DISTRIBUTORS LIST

Country	Company	Telephone	E-mail	Power Beam Meters Profilers
Argentina	Newport Corporation, Ophir USA	435-753-3729	timothy.cheng@mksinst.com	• •
Australia & N.Z	NewSpec Pty Ltd.	61 8 8463 1967	michael.ventura@newspec.com.au	• •
Austria	Ophir Spiricon Europe	49-6151-708-0	ose-sales@mksinst.com	• •
Belarus	Testpribor-M	375-17-310-60-99	pribor-minsk@tut.by	• •
Belgium	Ophir Spiricon Europe	49-6151-708-0	ose-sales@mksinst.com	• •
Brazil	New SOS Laser Com. De Acess	55-11-4229 3957	soslaser@soslaser.com.br	• •
Bulgaria	ASTEL	359-29-587-885 /86/89	n.georgiev@astelbg.com	• •
Canada (AB, BC, SK)	Newport Corporation, Ophir USA	435-753-3729	Timothy.Cheng@mksinst.com	• •
Canada (NS, ON, QC, MB, NB, NL)	Newport Corporation, Ophir USA	435-753-3729	Josh.Blackstock@mksinst.com	• •
Chile	Newport Corporation, Ophir USA	435-753-3729	timothy.cheng@mksinst.com	• •
China	Titan Electro Optics Co. Ltd.	86-10-6263-4840	sales@teo.com.cn	• •
Colombia / Costa Rica	Newport Corporation, Ophir USA	435-753-3729	timothy.cheng@mksinst.com	• •
Croatia	LRM	386 8 200 3155	robert.s@lrm.si	• •
Czech Republic	MIT s.r.o.	420-241-712-548	info@mit-laser.cz	• •
Denmark	4Photonics AB	46 701 911 820	info@4photonics.com	• •
Estonia	Cheos Oy	358-0-400 610344	sales@cheos.fi	• •
Finland	Cheos Oy	358-201-98-64-64	sales@cheos.fi	• •
France	Ophir Spiricon Europe	49-6151-708-0	ose-sales@mksinst.com	• •
Germany	Ophir Spiricon Europe	49-6151-708-0	ose-sales@mksinst.com	• •
Greece	Acta Ltd.	30-210-600-3302	ageo@acta.com.gr	• •
Hong Kong	Titan Electro Optics	86-755-8320-5020	wen-yan@teo.com.cn	• •
Hungary	Quantum Lasertech	36-30-539-1501	ugrai.gabor@quantumlasertech.hu	• •
India	New Age	91-022-27543777	tapan@newagein.com	• •
Indonesia	PT Serviam Abadimurni	62-21 8990-8142	serviam@centrin.net.id	• •
Ireland	Ophir Spiricon Europe	49-6151-708-0	ose-sales@mksinst.com	• •
Israel	Ophir Optronics Ltd.	972-2-548-7460	anat.bakal@mksinst.com	•
Israel	New Technology	972-3-679-2054	dvirs@newtech.co.il	•
Italy	Ophir Spiricon Europe GmbH	49-6151-708-0	ose-sales@mksinst.com	• •
Korea	Soleo Co., Ltd.	82-31-420-2744	sales4@eotechnics.com	• •
Korea	Jinsung Instruments Inc.	82-42-823 53001	jskim@jinsunginst.com	•
Latvia	Optec LTD	371 29 781 582	info@optek.lv	• •
Liechtenstein	Ophir Spiricon Europe	49-6151-708-0	ose-sales@mksinst.com	• •
Lithuania	Vildoma	370-5-236-3656	deimante.puryte@vildoma.lt	• •

Luxemburg	Ophir Spiricon Europe	49 6151 708-0	ose-sales@mksinst.com	•	•
Malaysia	Kumpulan Abex Sdn Bhd	603 5192 2898	sales@kabex.com.my	•	•
Malta	Suratek Ltd	356 215 74385	ktech1@maltanet.net	•	•
Mexico	Newport Corporation, Ophir USA	435-753-3729	timothy.cheng@mksinst.com	•	•
Middle East	Newport Corporation, Ophir USA	435-753-3729	timothy.cheng@mksinst.com	•	•
Netherlands	Ophir Spiricon Europe	49-6151-708-0	ose-sales@mksinst.com	•	•
Norway	4Photonics AB	46 701 911 820	info@4photonics.com	•	•
Poland	Scitec Instruments Polska	48-22-254-9218	dorota.siwiec@scitecinstruments.pl	•	•
Portugal	M.T.Brandão, Lda.	351 2261 67370	mtb@mtbrandao.com	•	•
Romania	Electro-Total.	40-21-252-5781	anca.movila@electro-total.com	•	•
Russia	ElektroSteklo Crystaltechno	7-495-234-5952	ambukov@crystaltechno.com	•	•
Serbia	LRM	386 8 200 3155	robert.s@lrm.si	•	•
Singapore	Newport Opto-Electronics Technologies (Singapore) Pte. Ltd.	65-6451-1062	sales.sg@mksinst.com	•	•
Slovakia	Kvant spol. s r.o.	421-2-6541-1344	Milan.Grigel@kvant.sk	•	•
Slovenia	LRM	386-8 200 3155	robert.s@lrm.si	•	•
South Africa	Hitech Laser Systems	27-12-349-1250	hls@hitechlasers.co.za	•	•
Spain - Excluding Catalonia	Lasing	34-913775006	alvaro.guadano@lasing.com	•	•
Spain - Catalonia	Ophir Spiricon Europe	49-6151-708-0	ose-sales@mksinst.com	•	•
Sweden	4Photonics AB	46 701 911 820	info@4photonics.com	•	•
Switzerland	Ophir Spiricon Europe	49-6151-708-0	ose-sales@mksinst.com	•	•
Taiwan	Unice E-O Services Inc.	886-3-462-6569	brianh@unice.com.tw	•	•
Taiwan	Titan Electro Optics Co.	886-2-2655-2200	sales@teo.com.tw	•	•
Thailand	Hakuto (Thailand)	66-2-255 8910	rachata@hakutothailand.com	•	•
Turkey	Mitra A.S.	90-212-347-4740	info@mitralaser.com	•	•
UK	Ophir Spiricon Europe	49-6151-708-0	ose-sales@mksinst.com	•	•
Ukraine	IVL Equipment & Engineering, Ltd	380- 44 499 2132	ivl@ivl.ua	•	•
USA - Southern Regional Sales Manager AR, TX, LA, OK, KS, FL, GA, MS, SC, AL, NC	Newport Corporation, Ophir USA	435-753-3729	chuck.reagan@mksinst.com	•	•
USA - Pacific Northwest, Mountain States, and Latin American Sales Manager Alaska, Colorado, Hawaii, Idaho, Montana, Oregon, Utah, Washington, Wyoming, Latin America (including Puerto Rico), Western Canada	Newport Corporation, Ophir USA	435-753-3729	Timothy.Cheng@mksinst.com	•	•
USA - Mid-Atlantic Regional Sales Manager NY, CT, RI, VT, NH, ME	Newport Corporation, Ophir USA	435-753-3729	joshua.blackstock@mksinst.com	•	•
USA - ND, SD, NE, MN, IA, WI, MO, VA WV, PA, MD, NJ, DE, DC	Newport Corporation, Ophir USA	435-753-3729	mark.szorik@mksinst.com	•	•
USA - IL, IN, OH, MI, KY	Newport Corporation, Ophir USA	435-753-3729	John.McCauley@mksinst.com	•	•
USA - Santa Barbara / Los Angeles Area, AZ, NM	Newport Corporation, Ophir USA	435-753-3729	dan.ford@mksinst.com	•	•
USA - Northern California / San Diego County	Newport Corporation, Ophir USA	435-753-3729	Nathan.Brouwer@mksinst.com	•	•
Vietnam	MTC Equipment	24 3719 8669	khoi.ng@mtc.vn	•	•

